

Technical Information

- CV** Check Valves
- SH** Shuttle Valves
- LM** Load/Motor Controls
- FC** Flow Controls
- PC** Pressure Controls
- LE** Logic Elements
- DC** Directional Controls
- MV** Manual Valves
- SV** Solenoid Valves
- PV** Proportional Valves
- CE** Coils & Electronics
- BC** Bodies & Cavities
- TD** Technical Data

General Description

4-Way, 2 Position, Reversing Spool Valve. For additional information see Technical Tips on pages SV1-SV6.

Features

- Designed to operate double and single acting cylinders, pilot circuits and bi-directional motors, etc.
- High flow capacity with reduced space requirements
- High pressure capacity to 350 Bar (5000 PSI)
- One piece cartridge housing ensures internal concentricity
- Coil: Waterproof, hermetically sealed, requires no O'Rings; Symmetrical coil can be reversed without affecting performance.
- Manual override available

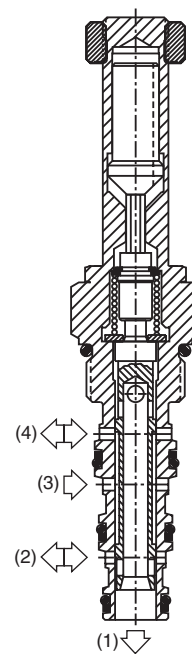
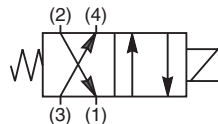

Specifications

Rated Flow (At 70 PSI ΔP)	19 LPM (5 GPM)
Maximum Inlet Pressure	350 Bar (5000 PSI)
Leakage at 150 SSU (32 cSt)	
Minimum Operating Voltage	85% of rated voltage at 20°C (72°F).
Cartridge Material	All parts steel. All operating parts hardened steel.
Operating Temp. Range/Seals	-40°C to +93.3°C (Nitrile) (-40°F to +200°F) -31.7°C to +121.1°C (Fluorocarbon) (-25°F to +250°F)
Fluid Compatibility/ Viscosity	Mineral-based or synthetic with lubricating properties at viscosities of 45 to 2000 SSU (6 to 420 cSt)
Filtration	ISO Code 16/13, SAE Class 4 or better
Approx. Weight	.30 kg (.66 lbs.)
Cavity	C08-4 (See BC Section for more details)

Performance Curves

Pressure Drop vs. Flow (Through cartridge only)

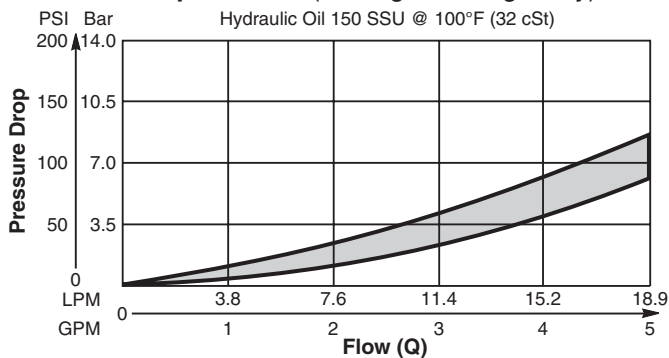

Operating Limits (Measured at 75% of Nominal Current)

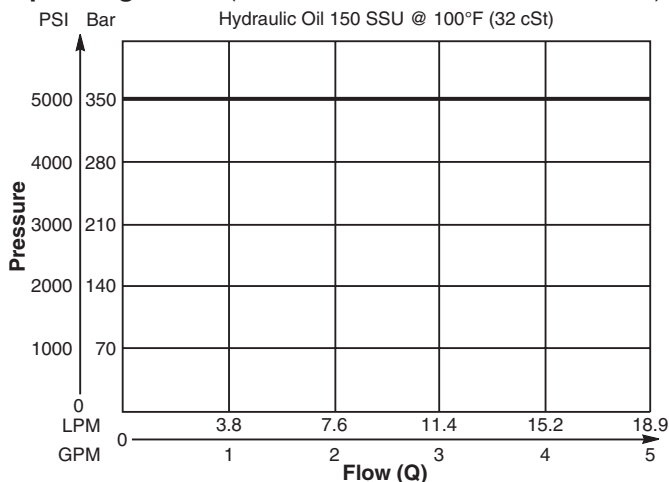

Technical Information

Dimensions Millimeters (Inches)

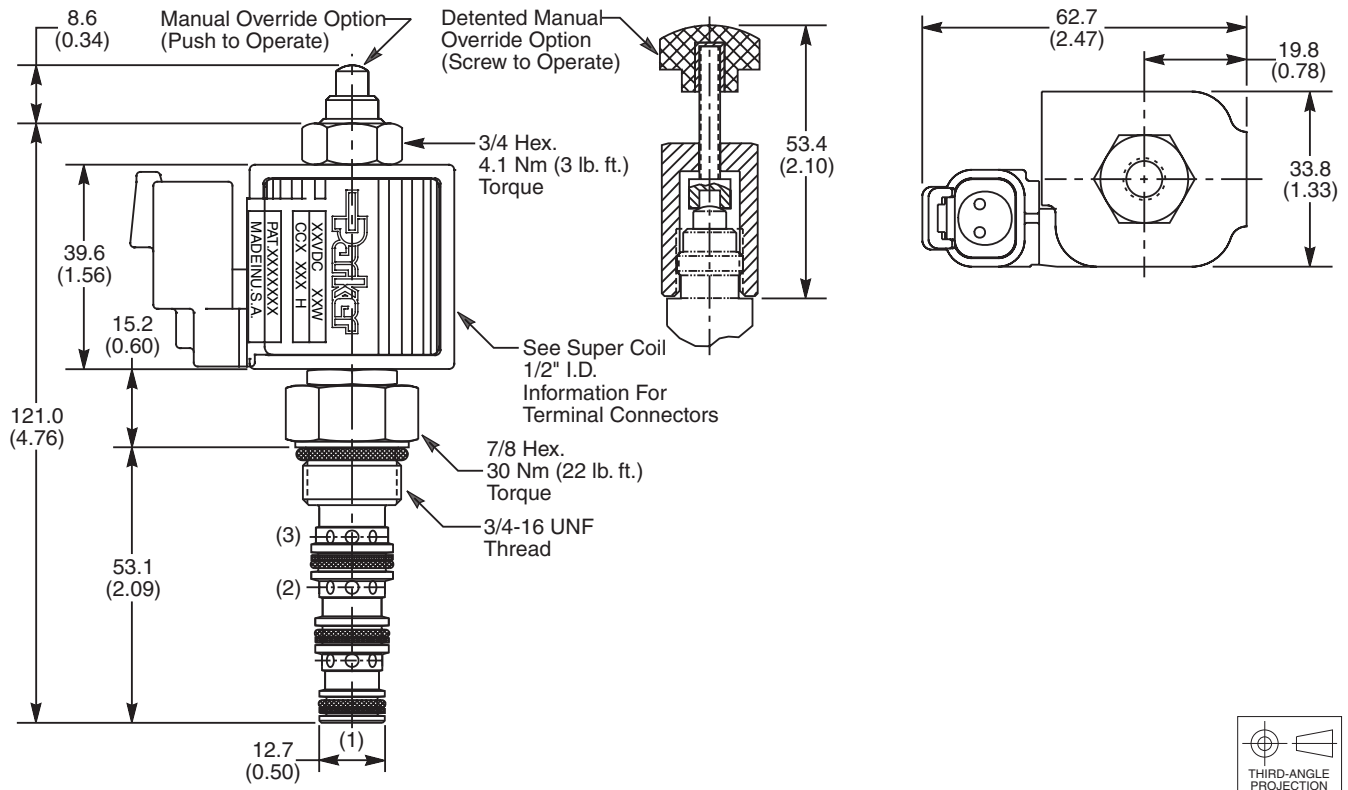

Ordering Information

GS02 **42**

08 Size Solenoid Valve Style Override Option Screen Seals Coil Type Coil Voltage Coil Termination Body Material Port Size

Code	Style
42	High Pressure ('SP' Coil)

Code	Seals / Kit No.
N	Nitrile / Buna-N (Std.) (SK30078N-1)
V	Fluorocarbon / (SK30078V-1)

Code	Coil Termination
Omit	Without Coil
C	Conduit With Leads
D	DIN Plug Face
A	Amp Jr. Timer*
S	Dual Spade*
L	Dual Lead Wire*
LS	Sealed Lead Wire*
H	Molded Deutsch*

Code	Body Material
Omit	Steel
A	Aluminum

Code	Override Options
0	None
1	Manual Override
2	Detented Part No. 900690

Code	Coil Type
Omit	Without Coil
SP	Super Coil - 19 Watts

Code	Port Size	Body Part No.
Omit	Cartridge Only	
6T	SAE-6	(B08-4-*6T)
6B	3/8" BSPG	(B08-4-*6B)

* Add "A" for aluminum, omit for steel.

Code	Screen
0	Not Available

Code	Coil Voltage
Omit	Without Coil
D012	12 VDC
D024	24 VDC
A120	120 VAC, 60/50 Hz
A240	240 VAC, 60/50 Hz*

*22 Watts

See Super Coil 1/2" I.D.
*DC Only

- CV Check Valves
- SH Shuttle Valves
- LM Load/Motor Controls
- FC Flow Controls
- PC Pressure Controls
- LE Logic Elements
- DC Directional Controls
- MV Manual Valves
- SV Solenoid Valves
- PV Proportional Valves
- CE Coils & Electronics
- BC Bodies & Cavities
- TD Technical Data

Technical Information

- CV** Check Valves
- SH** Shuttle Valves
- LM** Load/Motor Controls
- FC** Flow Controls
- PC** Pressure Controls
- LE** Logic Elements
- DC** Directional Controls
- MV** Manual Valves
- SV** Solenoid Valves
- PV** Proportional Valves
- CE** Coils & Electronics
- BC** Bodies & Cavities
- TD** Technical Data

General Description

4-Way Spool Valves. For additional information see Technical Tips on pages SV1-SV6.



Features

- High flow capacity with reduced space requirements
- Standard valve bodies and common cavities
- One-piece encapsulated coil with minimal amperage draw
- Manual overrides, seal variations and other options available
- No dynamic seals
- Variety of coil terminations
- Polyurethane "D"-Ring eliminates need for backup rings
- Nylon inserted jam-nut provides secure holding in high vibration applications
- All external parts zinc plated



DSL084B

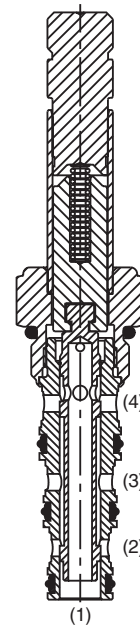
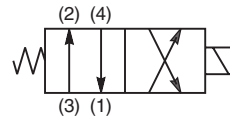

DSL084B

Specifications

Rated Flow	11-15 LPM (3-4 GPM)
Maximum Inlet Pressure	250 Bar (3600 PSI)
Leakage at 150 SSU (32 cSt)	160 cc/min. (10 in ³ /min.) at 250 Bar (3600 PSI)
Minimum Operating Voltage	85% of rated voltage at 20°C (72°F).
Response Time	Energized - 50 ms De-energized - 30 ms
Cartridge Material	All parts steel. All operating parts hardened steel.
Operating Temp. Range/Seals	-45°C to +93.3°C ("D"-Ring) (-50°F to +200°F) -31.7°C to +121.1°C (Fluorocarbon) (-25°F to +250°F)
Fluid Compatibility/Viscosity	Mineral-based or synthetic with lubricating properties at viscosities of 45 to 2000 SSU (6 to 420 cSt)
Filtration	ISO Code 16/13, SAE Class 4 or better
Approx. Weight	.13 kg (.29 lbs.)
Cavity	C08-4 (See BC Section for more details)
Form Tool	Rougher NFT08-4R Finisher NFT08-4F

Curve Selection Chart

SPOOL CODE	NEUTRAL					SHIFTED			
	4 to 1	3 to 2	2 to 1	3 to 1	3 to 4	4 to 1	3 to 2	2 to 1	3 to 4
B	4	3	—	—	—	—	—	2	4
E1	—	—	—	—	—	—	—	2	3
M	—	—	3	—	1	—	—	—	—
N	—	—	—	—	—	4	3	—	—

Performance Curves

Pressure Drop vs. Flow (Through cartridge only)

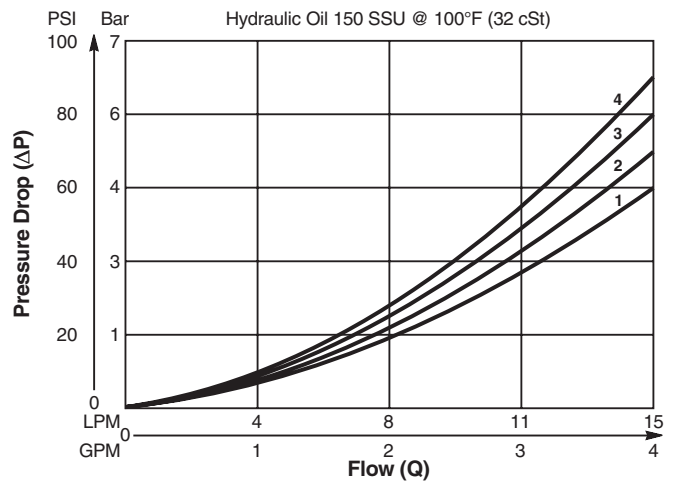

Shift Limit Characteristics (Min. Operating Voltage)

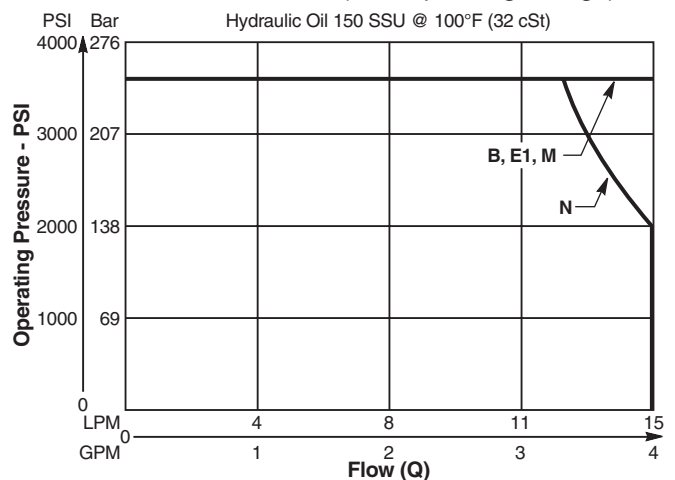

Dimensions Millimeters (Inches)

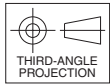
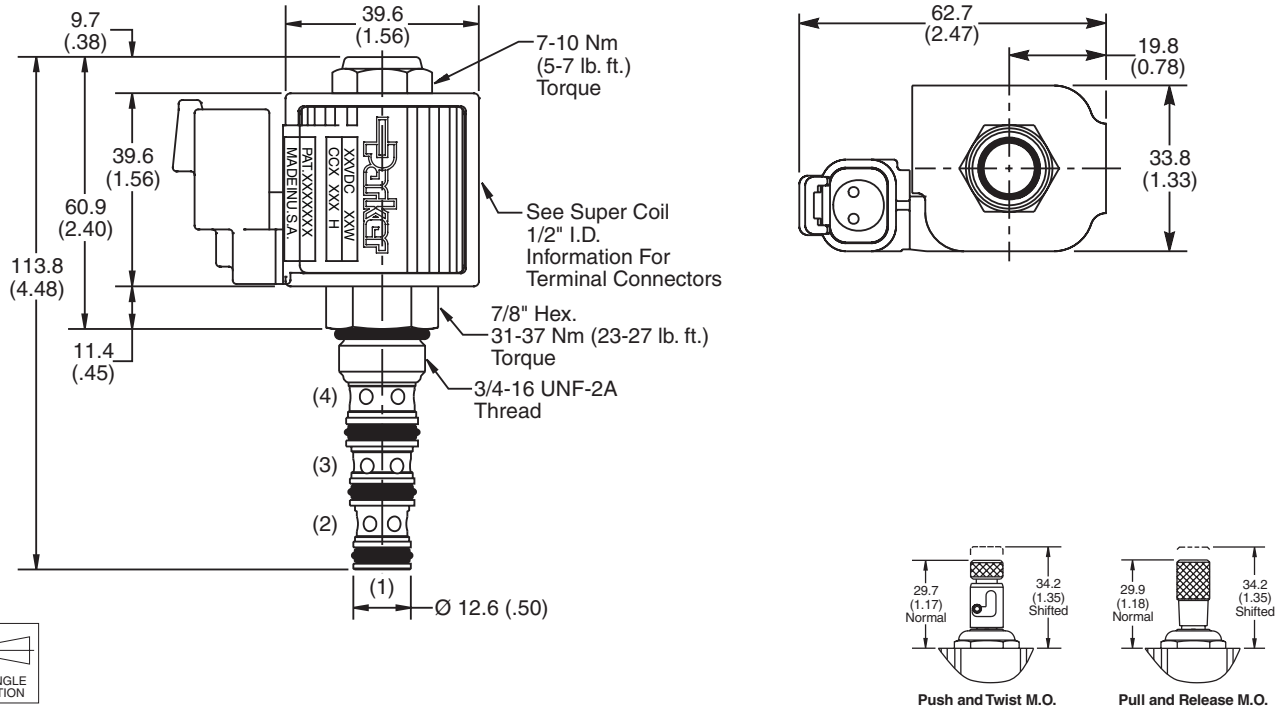

Ordering Information

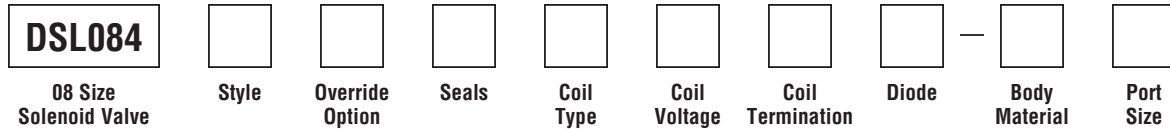

Code	Style
B	
N	
E1	
M	

Code	Override Options
Omit	None
P	Pull & Release
T	Push & Twist

Code	Seals / Kit No.
Omit	"D"-Ring / (SK08-4)
N	Nitrile / (SK08-4N)
V	Fluorocarbon / (SK08-4V)

Code	Coil Type
Omit	Without Coil
SP*	Super Coil - 19 Watts

*Recommended

Code	Coil Voltage
Omit	Without Coil
D012	12 VDC
D024	24 VDC
A120	120/110 VAC, 60/50 Hz
A240	240/220 VAC, 60/50 Hz

SP*	Coil Termination
Omit	Without Coil
C	Conduit With Leads
D	DIN Plug Face
A	Amp Jr. Timert
S	Dual Spade†
L	Dual Lead Wire†
LS	Sealed Lead Wire†
H	Molded Deutsch†

*Recommended
†DC Only

Code	Diode
Omit	None
R	Diode

Code	Body Material
Omit	Steel
A	Aluminum

Code	Port Size	Body Part No.
Omit	Cartridge Only	
4T	SAE-4	(B08-4-*4T)
6T	SAE-6	(B08-4-*6T)
6B	3/8" BSPG	(B08-4-*6B)

* Add "A" for aluminum, omit for steel.

Technical Information

- CV** Check Valves
- SH** Shuttle Valves
- LM** Load/Motor Controls
- FC** Flow Controls
- PC** Pressure Controls
- LE** Logic Elements
- DC** Directional Controls
- MV** Manual Valves
- SV** Solenoid Valves
- PV** Proportional Valves
- CE** Coils & Electronics
- BC** Bodies & Cavities
- TD** Technical Data

General Description

4-Way Spool Valves. For additional information see Technical Tips on pages SV1-SV6.



Features

- High flow capacity with reduced space requirements
- Standard valve bodies and common cavities
- One-piece encapsulated coil with minimal amperage draw
- Manual overrides, seal variations and other options available
- No dynamic seals
- Variety of coil terminations
- Polyurethane "D"-Ring eliminates need for backup rings
- Nylon inserted jam-nut provides secure holding in high vibration applications
- All external parts zinc plated

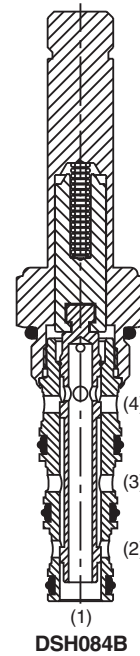
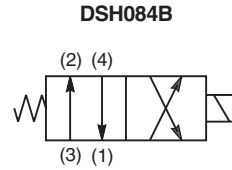

Specifications

Rated Flow	11-15 LPM (3-4 GPM)
Max. Inlet Pressure	350 Bar (5000 PSI)
Leakage at 150 SSU (32 cSt)	160 cc/min. (10 in ³ /min.) at 350 Bar (5000 PSI) DSH084B - 240 cc/min. (15 in ³ /min.)
Minimum Operating Voltage	85% of rated voltage at 20°C (72°F).
Response Time	Energized - 50 ms De-energized - 30 ms
Cartridge Material	All parts steel. All operating parts hardened steel.
Operating Temp. Range/Seals	-45°C to +93.3°C ("D"-Ring) (-50°F to +200°F) -31.7°C to +121.1°C (Fluorocarbon) (-25°F to +250°F)
Fluid Compatibility/Viscosity	Mineral-based or synthetic with lubricating properties at viscosities of 45 to 2000 SSU (6 to 420 cSt)
Filtration	ISO Code 16/13, SAE Class 4 or better
Approx. Weight	.13 kg (.29 lbs.)
Cavity	C08-4 (See BC Section for more details)
Form Tool	Rougher NFT08-4R Finisher NFT08-4F

Curve Selection Chart

SPOOL CODE	NEUTRAL					SHIFTED				
	4 to 1	3 to 2	2 to 1	3 to 1	3 to 4	4 to 1	3 to 2	2 to 1	3 to 4	
B	4	3	—	—	—	—	—	2	4	
E1	—	—	—	—	—	—	—	2	3	
M	—	—	3	—	1	—	—	—	—	
N	—	—	—	—	—	4	3	—	—	

Performance Curves

Pressure Drop vs. Flow (Through cartridge only)

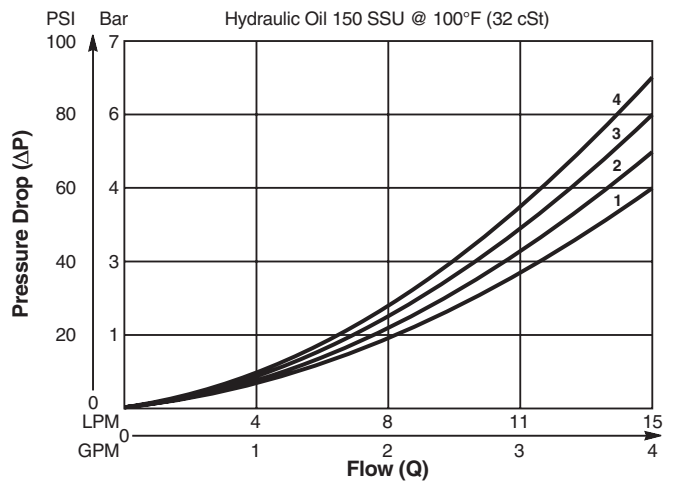

Shift Limit Characteristics (Min. Operating Voltage)

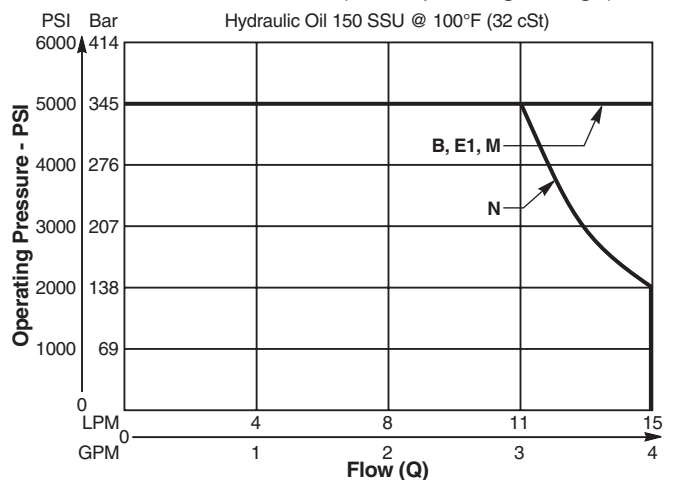

Dimensions Millimeters (Inches)

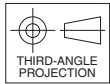
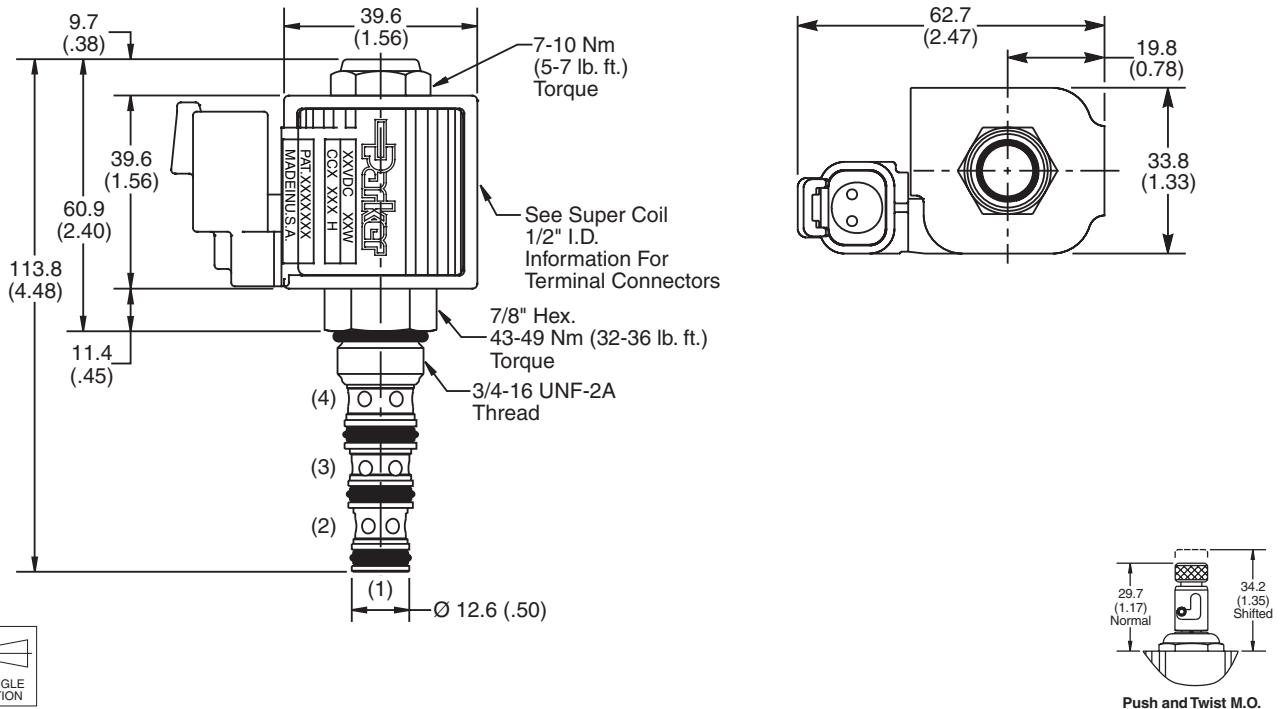

Ordering Information

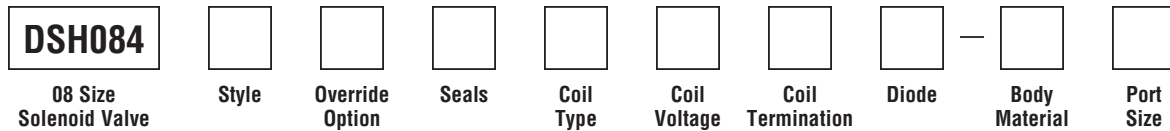

Code	Style
B	
N	
E1	
M	

Code	Override Options
Omit	None
T	Push & Twist*

**Requires Super Coil*

Code	Seals / Kit No.
Omit	"D"-Ring / (SK08-4)
N	Nitrile / (SK08-4N)
V	Fluorocarbon / (SK08-4V)

Code	Coil Type
Omit	Without Coil
SP*	Super Coil - 19 Watts

**Recommended*

Code	Coil Voltage
Omit	Without Coil
D012	12 VDC
D024	24 VDC
A120	120/110 VAC, 60/50 Hz
A240	240/220 VAC, 60/50 Hz

SP*	Coil Termination
Omit	Without Coil
C	Conduit With Leads
D	DIN Plug Face
A	Amp Jr. Timert
S	Dual Spade†
L	Dual Lead Wire†
LS	Sealed Lead Wire†
H	Molded Deutsch†

**Recommended
†DC Only*

Code	Diode
Omit	None
R	Diode

Code	Body Material
Omit	Steel
A	Aluminum

Code	Port Size	Body Part No.
Omit	Cartridge Only	
4T	SAE-4	(B08-4-*4T)
6T	SAE-6	(B08-4-*6T)
6B	3/8" BSPG	(B08-4-*6B)

** Add "A" for aluminum, omit for steel.*

Technical Information

- CV** Check Valves
- SH** Shuttle Valves
- LM** Load/Motor Controls
- FC** Flow Controls
- PC** Pressure Controls
- LE** Logic Elements
- DC** Directional Controls
- MV** Manual Valves
- SV** Solenoid Valves
- PV** Proportional Valves
- CE** Coils & Electronics
- BC** Bodies & Cavities
- TD** Technical Data

General Description

4-Way Spool Valves. For additional information see Technical Tips on pages SV1-SV6.



Features

- High flow capacity with reduced space requirements
- Standard valve bodies and common cavities
- One-piece encapsulated coil with minimal amperage draw
- Manual overrides, seal variations and other options available
- No dynamic seals
- Variety of coil terminations
- Polyurethane "D"-Ring
- All external parts zinc plated

Specifications

Rated Flow	27-38 LPM (7-10 GPM) See Shift Limit Characteristics
Maximum Inlet Pressure	250 Bar (3600 PSI)
Leakage at 150 SSU (32 cSt)	230 cc/min (14 in ³ /min)
Minimum Operating Voltage	85% of rated voltage at 20°C (72°F).
Response Time	Energized - 30 - 60 ms De-energized - 30 - 60 ms
Cartridge Material	All parts steel. All operating parts hardened steel.
Operating Temp. Range/Seals	-45°C to +93.3°C ("D"-Ring) (-50°F to +200°F) -31.7°C to +121.1°C (Fluorocarbon) (-25°F to +250°F)
Fluid Compatibility/Viscosity	Mineral-based or synthetic with lubricating properties at viscosities of 45 to 2000 SSU (6 to 420 cSt)
Filtration	ISO Code 16/13, SAE Class 4 or better
Approx. Weight	.20 kg (.44 lbs.)
Cavity	C10-4 (See BC Section for more details)
Form Tool	Rougher NFT10-4R Finisher NFT10-4F



DSL104B

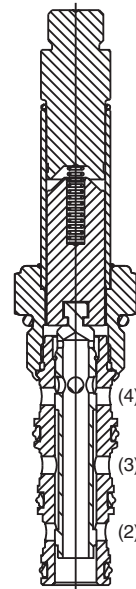
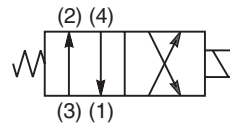

DSL104B

Performance Curves

Pressure Drop vs. Flow (Through cartridge only)

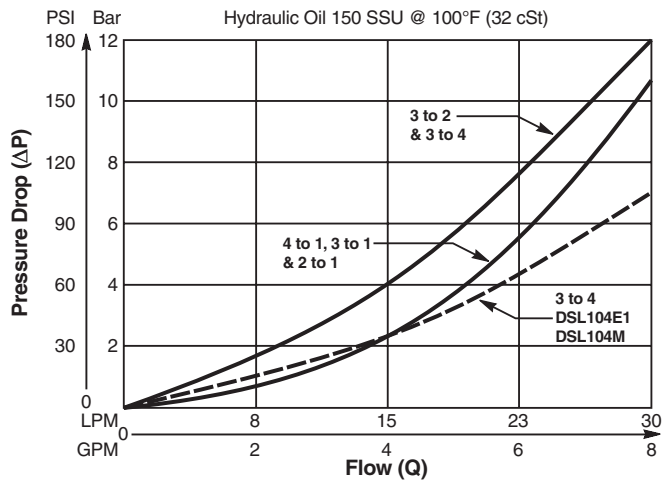

Shift Limit Characteristics (Min. Operating Voltage)

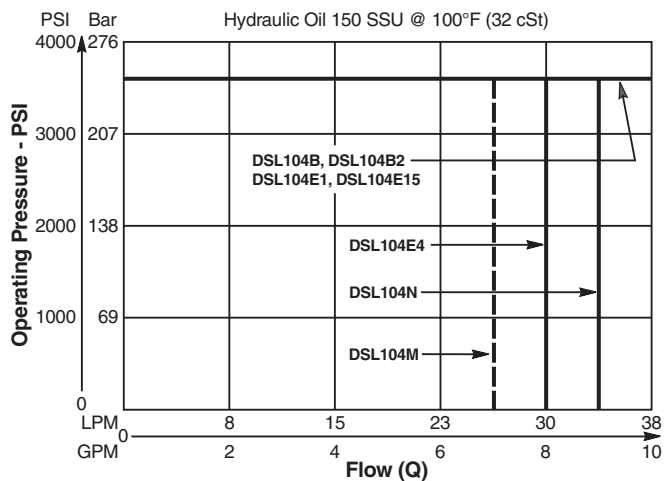

Dimensions Millimeters (Inches)

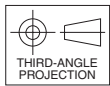
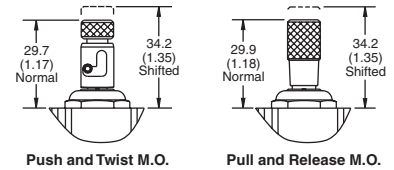
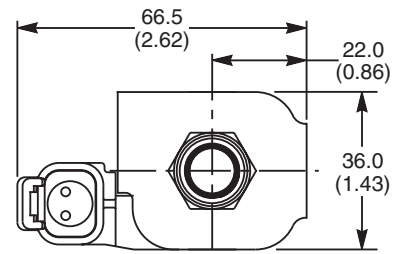
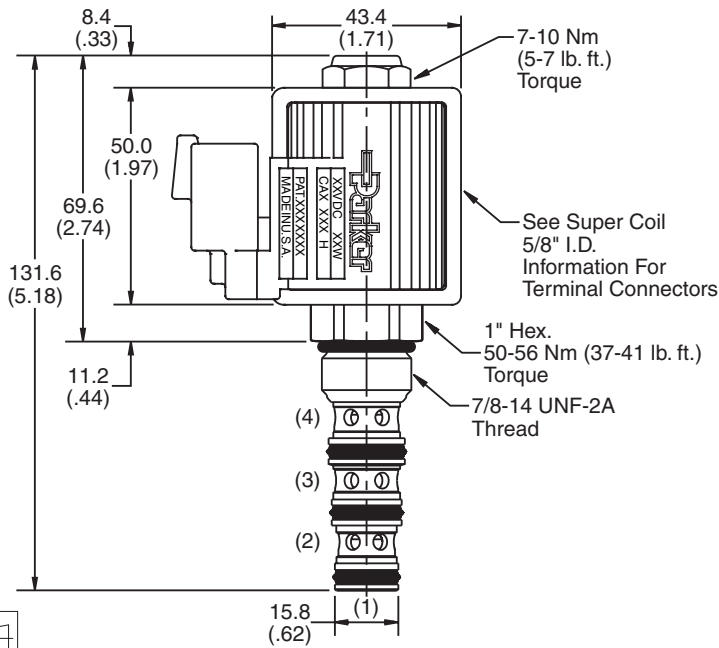

Ordering Information

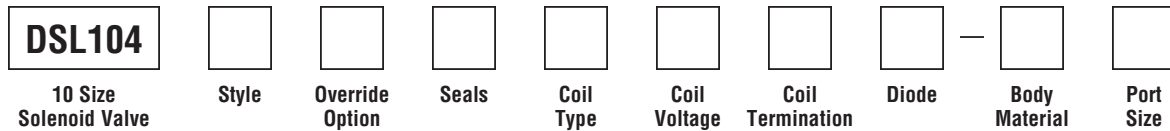

Code	Style
B	
B2	
E1	
E4	
E15	
M	
N	

Code	Override Options
Omit	None
P	Pull & Release
T	Push & Twist

Code	Seals / Kit No.
Omit	"D"-Ring / (SK10-4)
N	Nitrile / (SK10-4N)
V	Fluorocarbon / (SK10-4V)

Code	Coil Type
Omit	Without Coil
SP*	Super Coil - 28 Watts

*Recommended

Code	Coil Voltage
Omit	Without Coil
D012	12 VDC
D024	24 VDC
A120	120/110 VAC, 60/50 Hz
A240	240/220 VAC, 60/50 Hz

SP*	Coil Termination
Omit	Without Coil
C	Conduit With Leads
D	DIN Plug Face
A	Amp Jr. Timert†
S	Dual Spade†
L	Dual Lead Wire†
LS	Sealed Lead Wire†
H	Molded Deutsch†

*Recommended
 †DC Only

Code	Diode
Omit	None
R	Diode

Code	Body Material
Omit	Steel
A	Aluminum

Code	Port Size	Body Part No.
Omit	Cartridge Only	
6P	3/8" NTPF	(B10-4-*6P)
6T	SAE-6	(B10-4-*6T)
8T	SAE-8	(B10-4-*8T)
6B	3/8" BSPG	(B10-4-6B)†

* Add "A" for aluminum, omit for steel.
 † Steel bodies only

Technical Information

- CV** Check Valves
- SH** Shuttle Valves
- LM** Load/Motor Controls
- FC** Flow Controls
- PC** Pressure Controls
- LE** Logic Elements
- DC** Directional Controls
- MV** Manual Valves
- SV** Solenoid Valves
- PV** Proportional Valves
- CE** Coils & Electronics
- BC** Bodies & Cavities
- TD** Technical Data

General Description

4-Way Spool Valves. For additional information see Technical Tips on pages SV1-SV6.



Features

- High flow capacity with reduced space requirements
- Standard valve bodies and common cavities
- One-piece encapsulated coil with minimal amperage draw
- Manual overrides, seal variations and other options available
- No dynamic seals
- Variety of coil terminations
- Polyurethane "D"-Ring eliminates need for backup rings
- Nylon inserted jam-nut provides secure holding in high vibration applications
- All external parts zinc plated

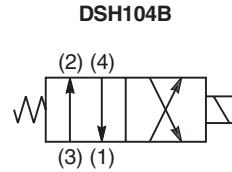
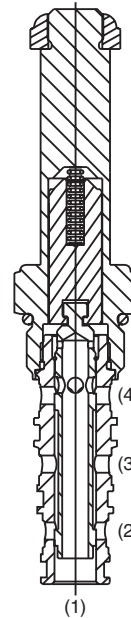

Specifications

Rated Flow	25 - 38 LPM (6.5 - 10 GPM) See Shift Limit Characteristics
Maximum Inlet Pressure	350 Bar (5000 PSI)
Leakage at 150 SSU (32 cSt)	160 cc/min (10 in ³ /min) DSH104B - 320 cc/min (19.5 in ³ /min)
Minimum Operating Voltage	85% of rated voltage at 20°C (72°F).
Response Time	Energized - 30 - 60 ms De-energized - 30 - 60 ms
Cartridge Material	All parts steel. All operating parts hardened steel.
Operating Temp. Range/Seals	-45°C to +93.3°C ("D"-Ring) (-50°F to +200°F) -31.7°C to +121.1°C (Fluorocarbon) (-25°F to +250°F)
Fluid Compatibility/Viscosity	Mineral-based or synthetic with lubricating properties at viscosities of 45 to 2000 SSU (6 to 420 cSt)
Filtration	ISO Code 16/13, SAE Class 4 or better
Approx. Weight	.20 kg (.44 lbs.)
Cavity	C10-4 (See BC Section for more details)
Form Tool	Rougher NFT10-4R Finisher NFT10-4F

Performance Curves

Pressure Drop vs. Flow (Through cartridge only)

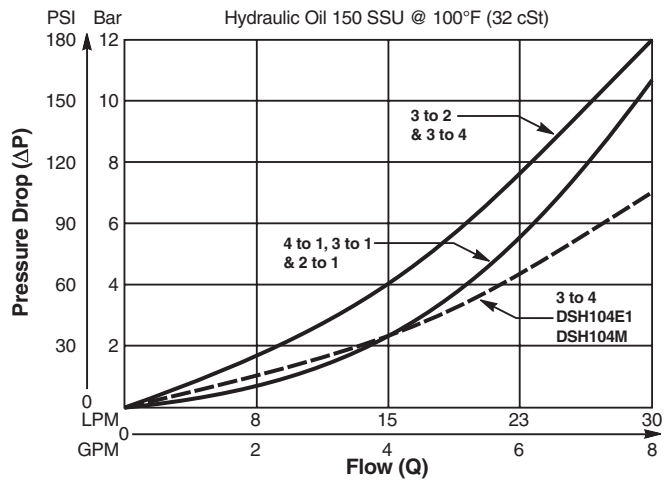

Shift Limit Characteristics (Min. Operating Voltage)

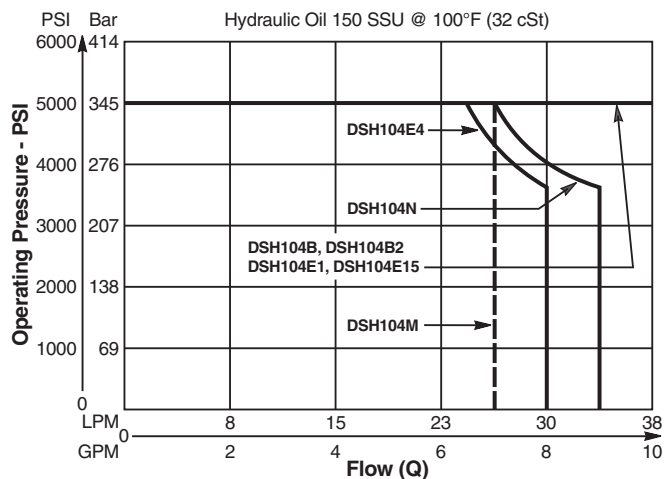

Dimensions Millimeters (Inches)

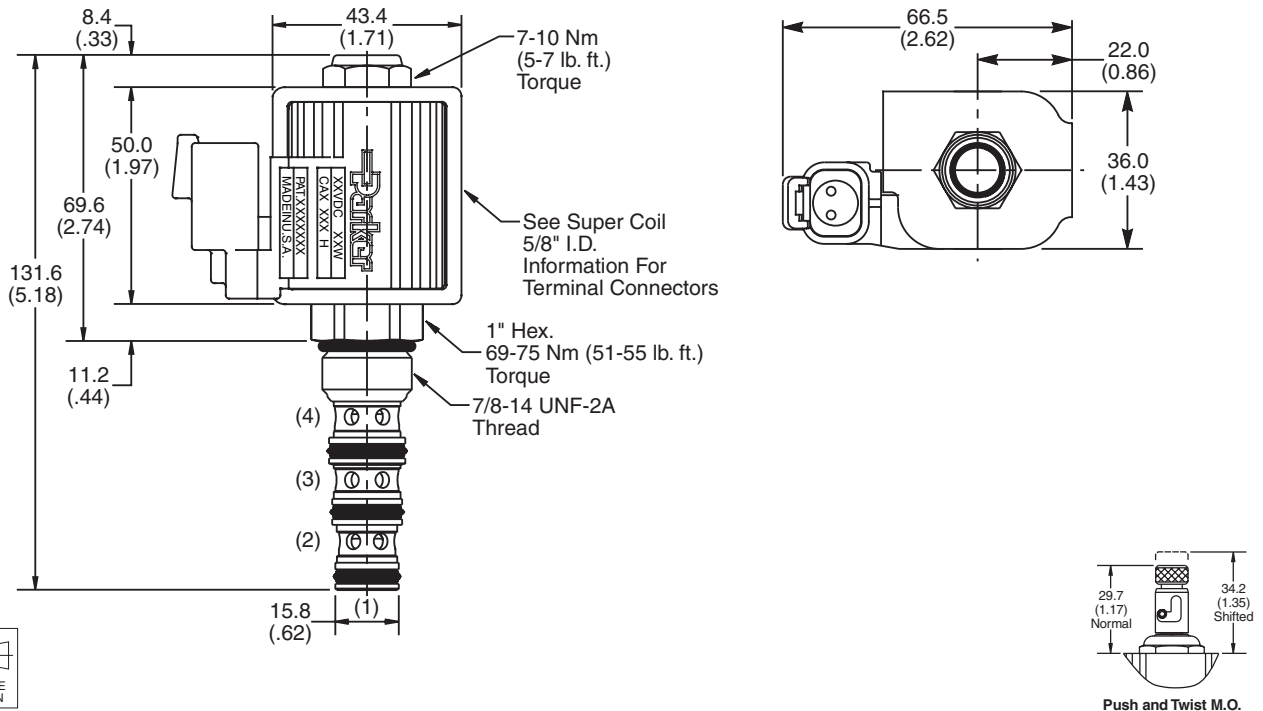

Ordering Information

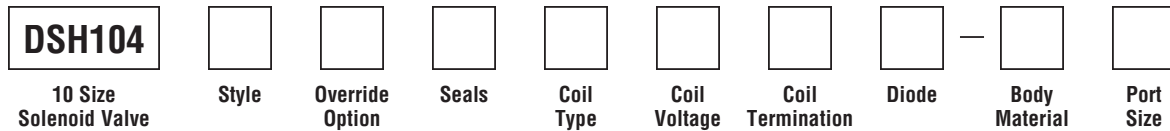

Code	Style
B	
B2	
E1	
E4	
E15	
M	
N	

Code	Override Options
Omit	None
T	Push & Twist

Code	Seals / Kit No.
Omit	"D"-Ring / (SK10-4)
N	Nitrile / (SK10-4N)
V	Fluorocarbon / (SK10-4V)

Code	Coil Type
Omit	Without Coil
SP*	Super Coil - 28 Watts

*Recommended

Code	Coil Voltage
Omit	Without Coil
D012	12 VDC
D024	24 VDC
A120	120/110 VAC, 60/50 Hz
A240	240/220 VAC, 60/50 Hz

SP*	Coil Termination
Omit	Without Coil
C	Conduit With Leads
D	DIN Plug Face
A	Amp Jr. Timert
S	Dual Spade†
L	Dual Lead Wire†
LS	Sealed Lead Wire†
H	Molded Deutsch†

*Recommended
 †DC Only

Code	Diode
Omit	None
R	Diode

Code	Body Material
Omit	Steel
A	Aluminum

Code	Port Size	Body Part No.
Omit	Cartridge Only	
6P	3/8" NTPF	(B10-4-*6P)
6T	SAE-6	(B10-4-*6T)
8T	SAE-8	(B10-4-*8T)
6B	3/8" BSPG	(B10-4-6B)†

* Add "A" for aluminum, omit for steel.
 † Steel bodies only

Technical Information

- CV** Check Valves
- SH** Shuttle Valves
- LM** Load/Motor Controls
- FC** Flow Controls
- PC** Pressure Controls
- LE** Logic Elements
- DC** Directional Controls
- MV** Manual Valves
- SV** Solenoid Valves
- PV** Proportional Valves
- CE** Coils & Electronics
- BC** Bodies & Cavities
- TD** Technical Data

General Description

4-Way Spool Valves. For additional information see Technical Tips on pages SV1-SV6.

Features

- High flow capacity with reduced space requirements
- Standard valve bodies and common cavities
- One-piece encapsulated coil with minimal amperage draw
- Seal variations and other options available
- No dynamic seals
- Variety of coil terminations
- Nylon inserted jam-nut provides secure holding in high vibration applications
- All external parts zinc plated

Application Note

This valve is a pilot operated spool type valve. It does not require a separate pilot supply, but does require that the work port pressure or the inlet pressure is 40-60 psi higher than port 1. In an open flowing condition, with zero load and low flow, it will require a 4-6 gpm flow to create internal pilot pressure to shift. If load pressure or system pressure is 40-60 psi higher than tank, the valve will shift. Ultimately, the valve shifts based upon pressure differential from port 3 to port 1 of 40-60 psi.

Specifications

Rated Flow	114 LPM (30 GPM)
Maximum Inlet Pressure	350 Bar (5000 PSI)
Leakage at 150 SSU (32 cSt)	350 cc/min (21 in ³ /min) De-Energ. 5.6 LPM (1.5 GPM) Energized Pilot Flow @ 207 Bar (3000 PSI)
Minimum Operating Voltage	85% of rated voltage at 20°C (72°F).
Response Time	Pull In - 600 ms Drop Out - 130 ms
Cartridge Material	All parts steel. All operating parts hardened steel.
Operating Temp. Range/Seals	-40°C to +93.3°C (Nitrile) (-40°F to +200°F) -31.7°C to +121.1°C (Fluorocarbon) (-25°F to +250°F)
Fluid Compatibility/Viscosity	Mineral-based or synthetic with lubricating properties at viscosities of 45 to 2000 SSU (6 to 420 cSt)
Filtration	ISO Code 16/13, SAE Class 4 or better
Approx. Weight	.59 kg (1.3 lbs.)
Cavity	C16-4 (See BC Section for more details)
Form Tool	Rougher NFT16-4R Finisher NFT16-4F

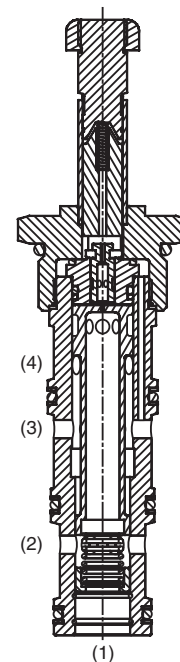
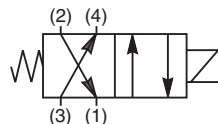

Performance Curves

Pressure Drop vs. Flow (Through cartridge only)

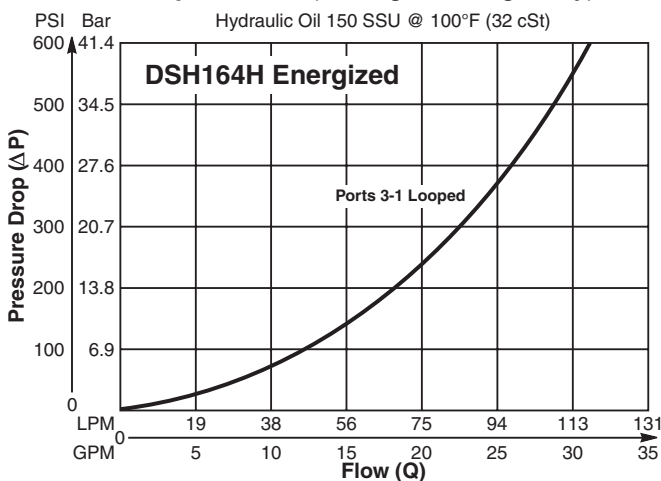

Pressure Drop vs. Flow (Through cartridge only)

