

**General Description**

Series D30FP pilot operated control valve closes the gap between the direct operated D3FP valves and the conventional pilot operated D31FP valves.

Providing high flow capacity and practically no flow limits like D31FP in the envelope size of the D3FP.

The valve works with the hydraulic follower principle, with a moving sleeve as main spool.

**Features**

- Pilot operated with hydraulic follower sleeve.
- No flow limit up to 350 bar through the valve.
- Defined spool positioning at power down.

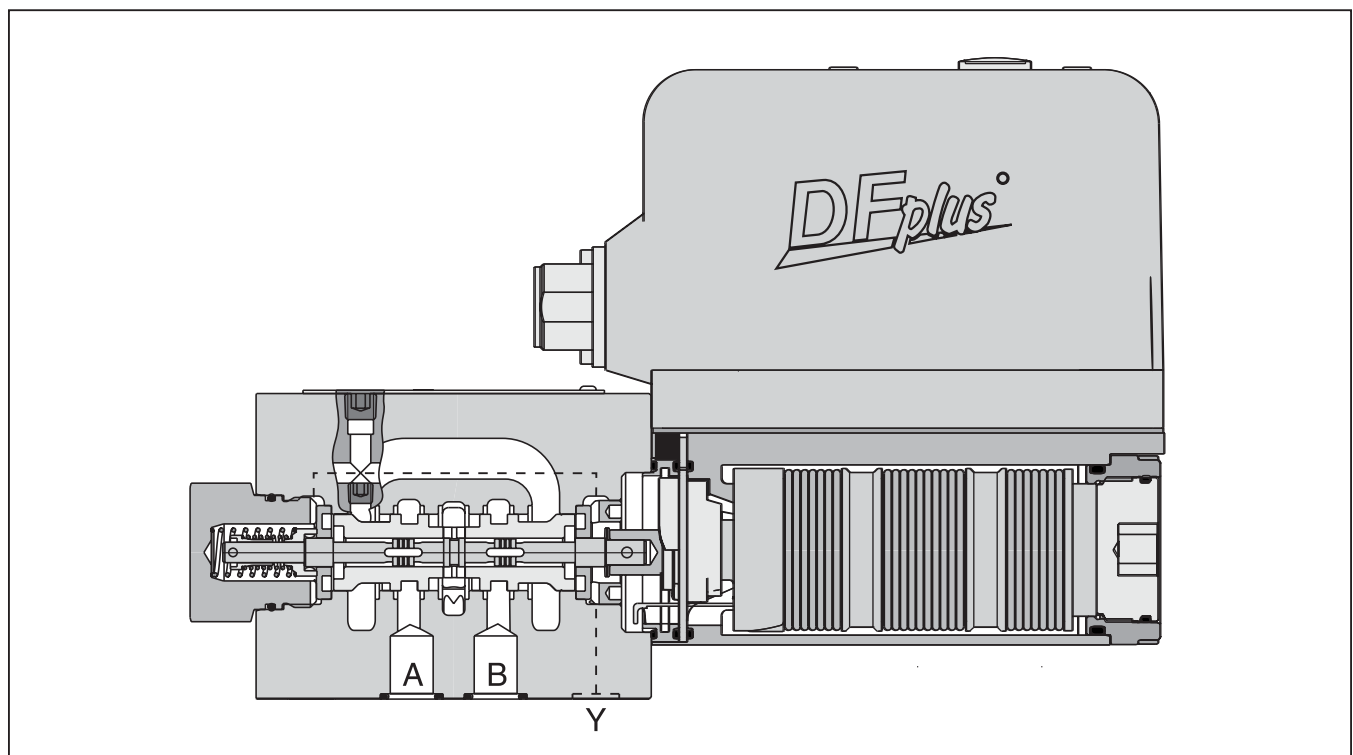
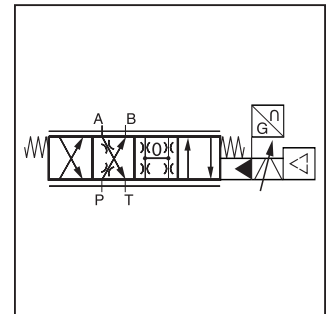
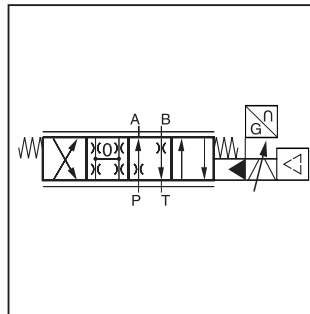
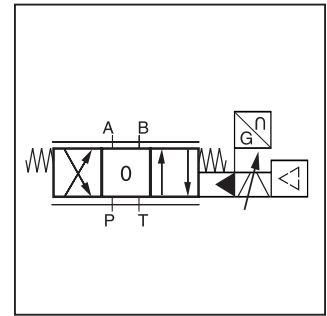
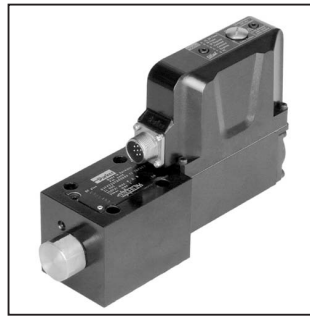

**A**

**D**

Directional Control Valve

**30**

Size  
 DIN NG10  
 CETOP 5  
 NFPA D05

**F**

Proportional Control

**P**

VCD

Spool Type

Spool Position on Power Down

Pilot Connection

Seal

Input Signal

Options

**3**

Spool/Sleeve Design

Design Series

NOTE:  
 Not required when ordering.

Code	Spool	Flow LPM (GPM) at $\Delta p$ 5 Bar (72.5 PSI) per metering edge
<b>Zerolap</b>		
E50U		80 (21.2)
B60U	$Q_B = Q_A/2$ 	80 (21.2)
<b>Overlap 18%</b>		
E01U		80 (21.2)
E02U		80 (21.2)
B31U	$Q_B = Q_A/2$ 	80 (21.2)
B32U	$Q_B = Q_A/2$ 	80 (21.2)

Code	Description
N	Nitrile
V	Fluorocarbon

Code	Description
0	6 + PE acc. EN175201-804
5	11 + PE acc. EN175201-804
7	6 + PE + Enable

Code	Inlet	Dain
1 <sup>1)</sup>	Internal	External
4	Internal	Internal

<sup>1)</sup> For tank pressure >35 Bar (508 PSI).

Code	Signal	Flow Direction <sup>4)</sup>
B	+/- 10V	0...+10V -> P-A
E	+/- 20mA	0...+20mA -> P-A
S	4...20mA	12...20mA -> P-A

<sup>4)</sup> Flow direction P → A with Pin D > Pin E.

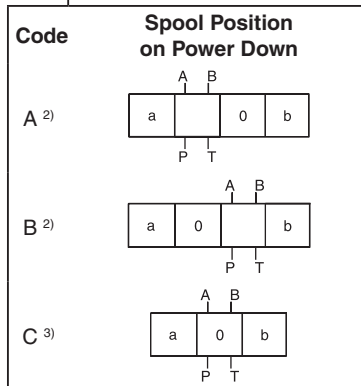

<sup>2)</sup> Approximately 10% opening, only available with zerolap spools and underlap spools.

<sup>3)</sup> Only available with overlap spools.

Please order plugs separately. See Accessories.

**Bolt Kit:**

BK98 (4) 1/4-20x1.62  
 BK385 (4) M6x40

**Weight:** 6.5 kg (14.3 lbs.)

General		
Design	Pilot operated proportional DC valve	
Actuation	VCD® actuator	
Size	NG10 / CETOP 5 / NFPA D05	
Mounting Interface	DIN 24340 / ISO 4401 / CETOP RP121 / NFPA	
Mounting Position	Unrestricted	
Ambient Temperature	[°C]	-20...+50; (-4°F...+122°F)
MTTF <sub>d</sub> Value	[years]	50
Vibration Resistance	[g]	10 Sinus 5...2000 Hz acc. IEC 68-2-6 30 Random noise 20...2000 Hz acc. IEC 68-2-36 15 Shock acc. IEC 68-2-27
Hydraulic		
Maximum Operating Pressure	Ports P, A, B 350 Bar (5075 PSI) Port T 35 Bar (508 PSI) for internal drain, 250 Bar (3600 PSI) for external drain Port Y 35 Bar (508 PSI)	
Fluid	Hydraulic oil as per DIN 51524...51535, other on request	
Fluid Temperature	[°C]	-20...+60; (-4°F...+140°F)
Viscosity		
Permitted	[cSt] / [mm²/s]	20...380 (93...1761 SSU)
Recommended	[cSt] / [mm²/s]	30...80 (139...371 SSU)
Filtration	ISO 4406 (1999) 18/16/13 (acc. NAS 1638: 7)	
Nominal Flow at Δp=5 Bar (72.5 PSI) per Control Edge <sup>1)</sup>	80 LPM (21.2 GPM)	
Flow Maximum	250 LPM (66.1 GPM)	
Leakage at 100 Bar (1450 PSI)	[ml/min]	<1800 (zerolap spool); <1000 (overlap spool)
Pilot Supply Pressure	5 Bar (72.5 PSI) greater than the tank line pressure	
Static / Dynamic		
Step Response at 100% Step <sup>2)</sup>	[ms]	<7
Frequency Response (±5% signal) <sup>2)</sup>	[Hz]	120 (amplitude ratio -3dB), 120 (phase lag -90°)
Hysteresis	[%]	<0.05
Sensitivity	[%]	<0.03
Temperature Drift	[%/K]	<0.025
Electrical		
Duty Ratio	[%]	100 ED; CAUTION: Coil temperature up to 150°C (302°F) possible
Protection Class	IP65 in accordance with EN 60529 (plugged and mounted)	
Supply Voltage/Ripple	[V]	DC 22 ... 30, ripple <5% eff., surge free
Current Consumption Maximum	[A]	3.5
Pre-Fusing	[A]	4.0 medium lag
Input Signal		
Voltage	[V]	10...0...-10, ripple <0.01% eff., surge free, 0...+10V P->A
Impedance	[kOhm]	100
Current	[mA]	20...0...-20, ripple <0.01% eff., surge free, 0...+20mA P->A
Impedance	[Ohm]	250
Current	[mA]	4...12...20, ripple <0.01% eff., surge free, 12...20mA P->A
Impedance	[Ohm]	<3.6 mA = disable, >3.8 mA = according to NAMUR NE43 250
Differential Input Maximum		
Code 0	[V]	30 for terminal D and E against PE (terminal G)
Code 5 / 7	[V]	30 for terminal 4 and 5 against PE (terminal ⊥)
Enable Signal (Only Code 5 / 7)	[V]	5...30, Ri = 9 kOhm
Diagnostic Signal	[V]	+10...0...-10 / +Ub, rated max. 5mA
EMC	EN 50081-2 / EN50082-2	
Electrical Connection		
Code 0	6 + PE acc. EN 175201-804	
Code 5	11 + PE acc. EN 175201-804	
Code 7	6 + PE + Enable	
Wiring Minimum		
Code 0	[mm²]	7 x 1.0 (AWG 18) overall braid shield
Code 5	[mm²]	12 x 1.0 (AWG 20) overall braid shield
Code 7	[mm²]	12 x 1.0 (AWG 18) overall braid shield
Wiring Length Maximum	[m]	50 (164 ft.)

1) Flow rate for different Δp per control edge:  $Q_x = Q_{Nom.} \cdot \sqrt{\frac{\Delta p_x}{\Delta p_{Nom.}}}$

2) Measured with load (100 Bar (1450 PSI) pressure drop/two control edges)

**Flow**

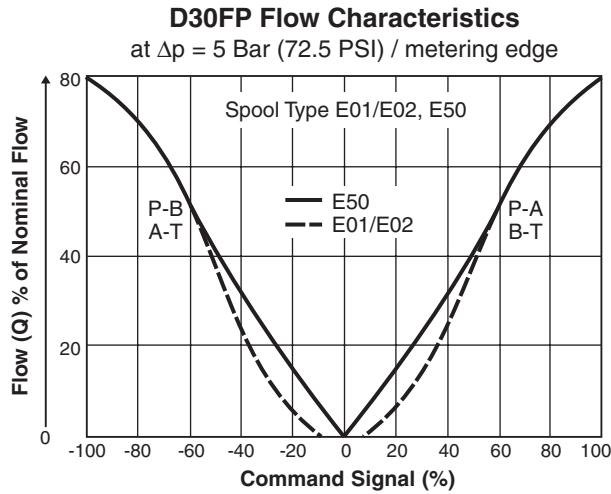

**Pressure Gain**

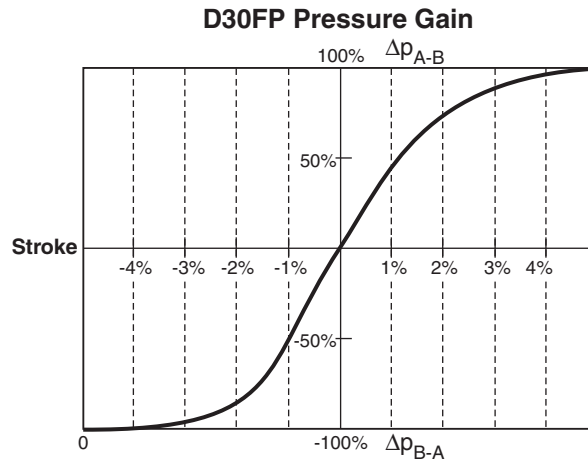

**Frequency Response**

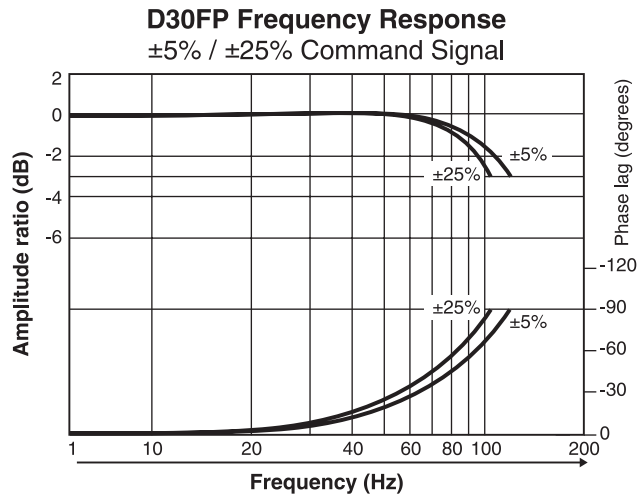

**Code 0**

**6 + PE acc. to EN 175201-804**

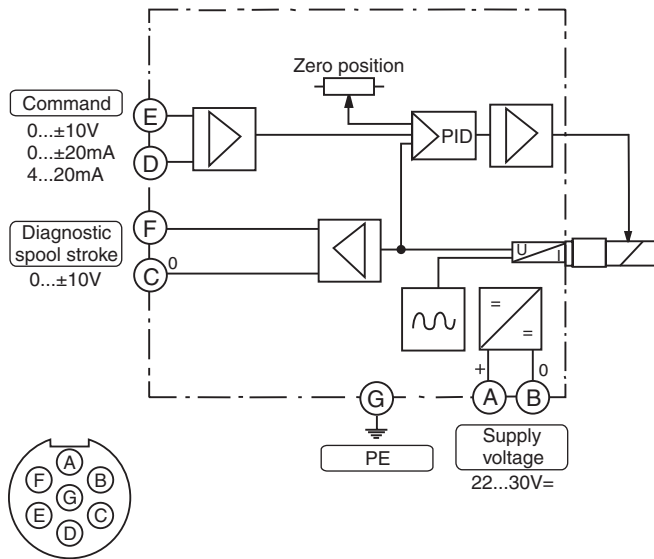

**Code 5**

**11 + PE acc. to EN 175201-804**

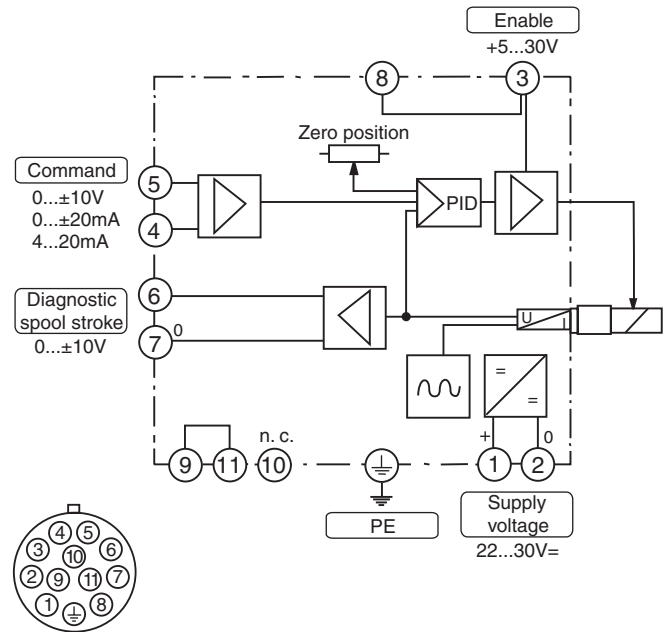

**Code 7**

**6 + PE + Enable acc. to EN 175201-804**

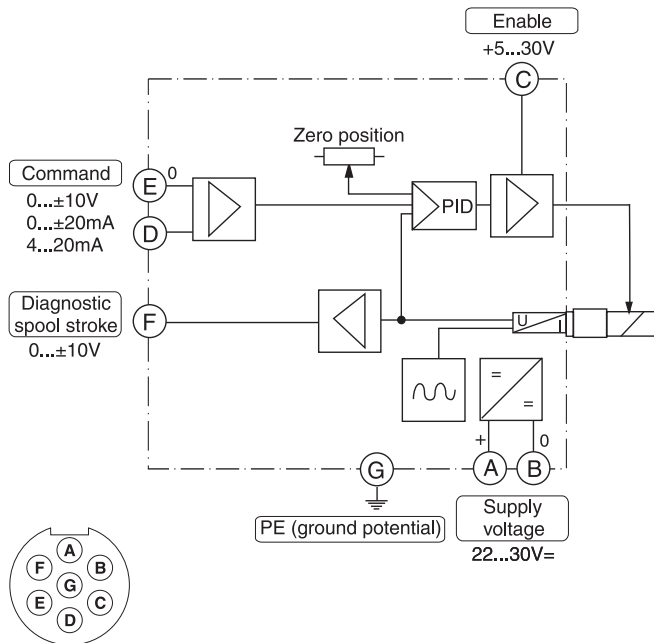

Inch equivalents for millimeter dimensions are shown in (\*\*)

**A**

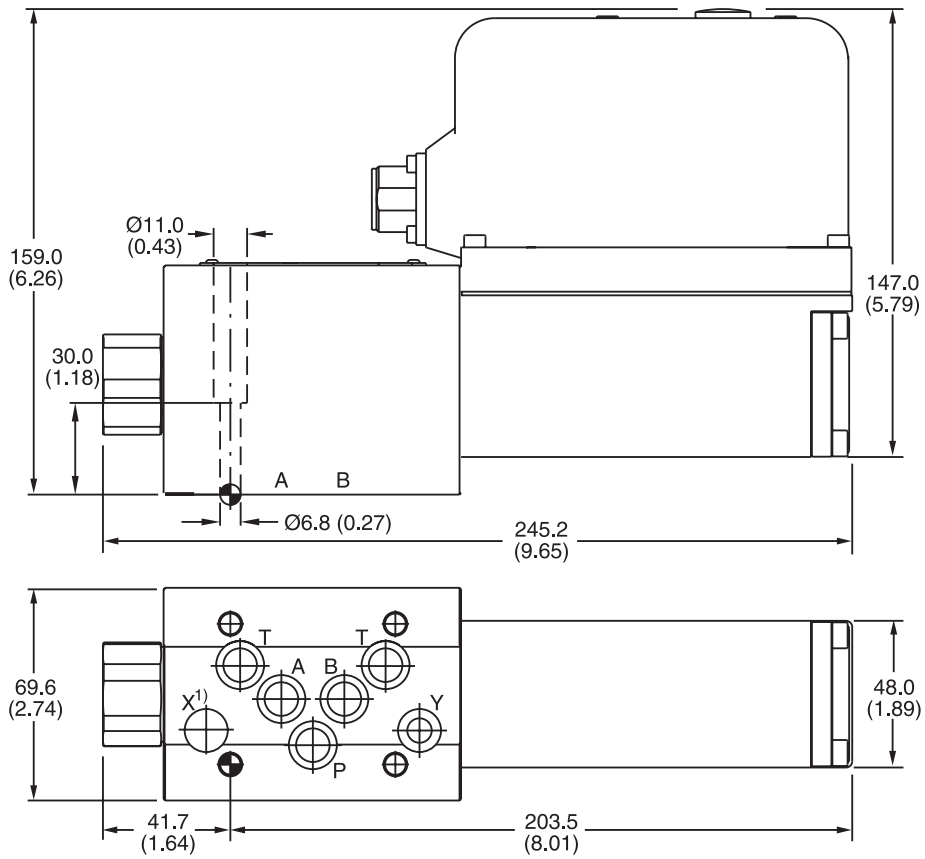

Surface Finish	Kit	Kit	Kit	Seal Kit
	BK385 BK98	4x M6x40 DIN 912 12.9 4x 1/4-20x1.62	13.2 Nm (9.7 lb.-ft.) ±15 %	Nitrile: SK-D3FP Fluorocarbon: SK-D3FP-V