



aerospace  
climate control  
electromechanical  
**filtration**  
fluid & gas handling  
hydraulics  
pneumatics  
process control  
sealing & shielding



# World Pressure Filters

A New Standard in 7,000 psi Pressure Filters



ENGINEERING YOUR SUCCESS.

# WPF Series

## Applications

### Together we can...

**P**reserve the environment.  
Minimize waste and promote energy efficiency.

**A**chieve worldwide filtration solutions.  
Build global confidence.

**R**edefine new limits.  
Forge ahead with advanced technology.

**K**eep contamination under control.  
Reduce maintenance costs.

**E**nhance total system reliability.  
Focus on customer satisfaction.

**R**each optimum potential.  
Drill to greater depths.

...engineer your success.

Parker engineers have developed what soon will be the industry standard in high pressure hydraulic filtration. The new 7,000 psi WPF series incorporates many advanced features designed for one reason: to improve your bottom line.



### Typical Applications

- Aircraft Ground Support
- Injection Molding
- Mining
- Mobile Ag
- Mobile Construction
- Oil & Gas Exploration
- Power Generation
- Primary Metals
- Refuse Trucks



There is no better high pressure filter available today for durability and performance. The reduction of your operating costs is our primary concern, and we are committed to contributing towards your success.



# WPF Series

## Features



- 1** High strength ductile iron filter head with integral indicator port
- 2** Steel bowl with standard drain port
- 3** Proprietary element endcap assembly includes bypass and reverse flow valves
- 4** Patented deformable tangs secure element in bowl
- 5** Coreless element assembly
- 6** Re-usable element support core

# WPF Series

## SurgeGuard Elements

Ecoglass design  
Non-metallic construction

Environmentally friendly.  
Reduced disposal costs due to  
minimum mass and oil retention

Proprietary  
SurgeGuard protection  
System protection  
from back-flow

Component performance  
integrity with improved flow fatigue  
resistance

Integrated bypass & reverse flow  
valve technology  
Every element serviced provides  
new bypass &  
reverse flow valve assembly

Reliable, high performance, quick  
response design

Low mass, low  $\Delta P$   
reverse flow valve  
Ideal for closed-loop  
applications

Greater design and  
service flexibility

Patented  
deformable tangs  
Automatic element  
locate and removal

Easy, fast, safe, clean

Element removal  
clearance  
Benchmarked best-in-class  
against major competitors

Ease-of-service.  
Machine design flexibility

Patented valves  
with low hysteresis  
Zero leakage  
and low friction

Optimum performance



# WPF Series

## WPF1 Element Performance

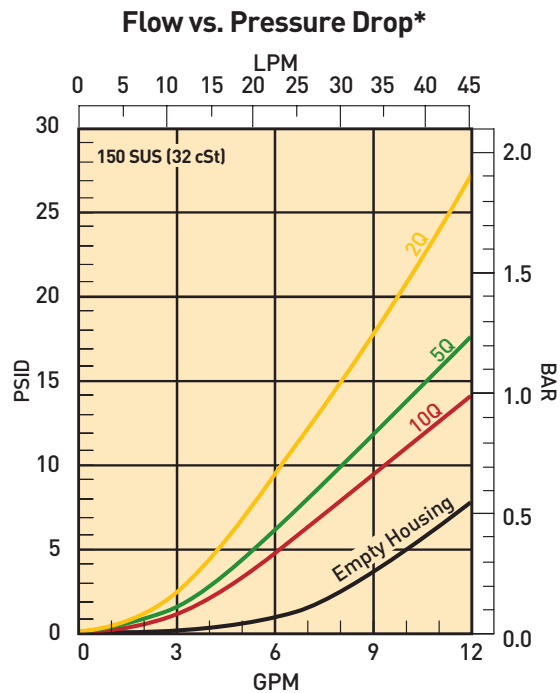
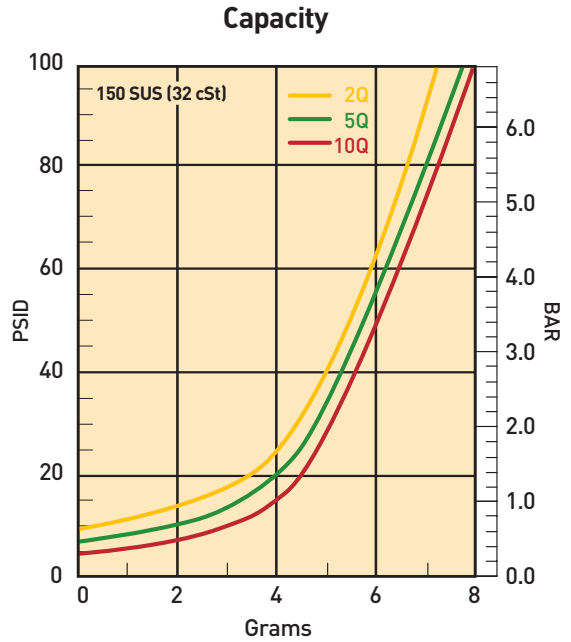
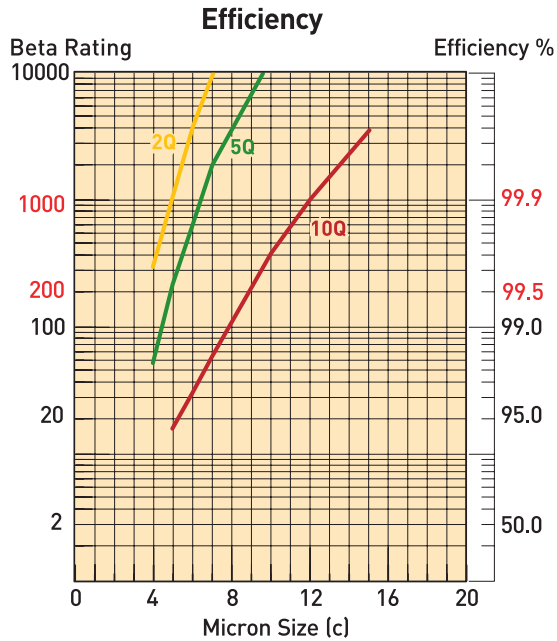

\*High Collapse Correction Factor:  
 "QH" Elements (2000 psid) = 1.4 times reported loss

Results typical from Multi-pass tests run per test standard ISO 16889 @ 10 gpm to 50 psid terminal - 10 mg/L BUGL.

Note: During reverse flow,  $\Delta P$  is 20 psid at max. flow.

# WPF Series

## WPF2 Element Performance

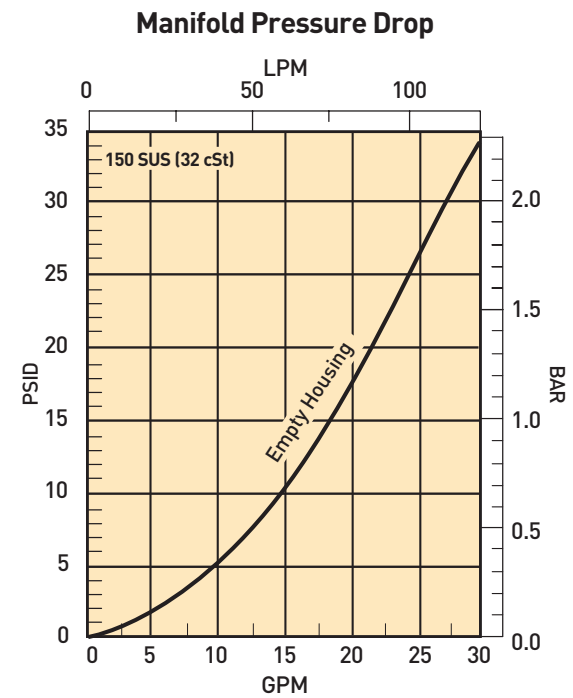
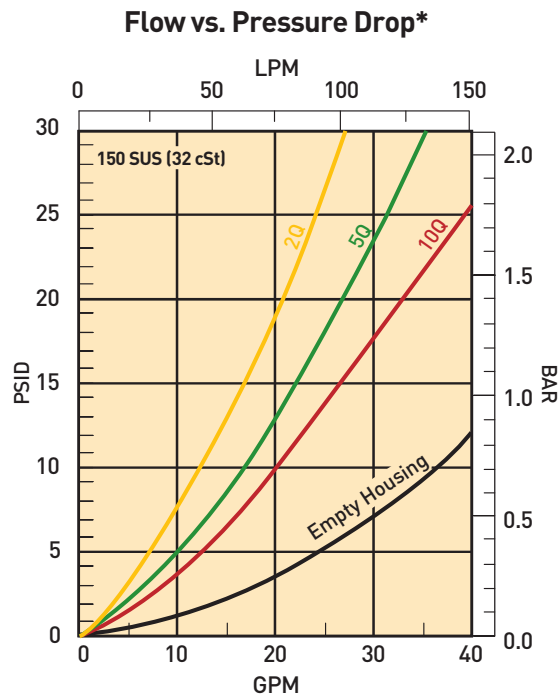
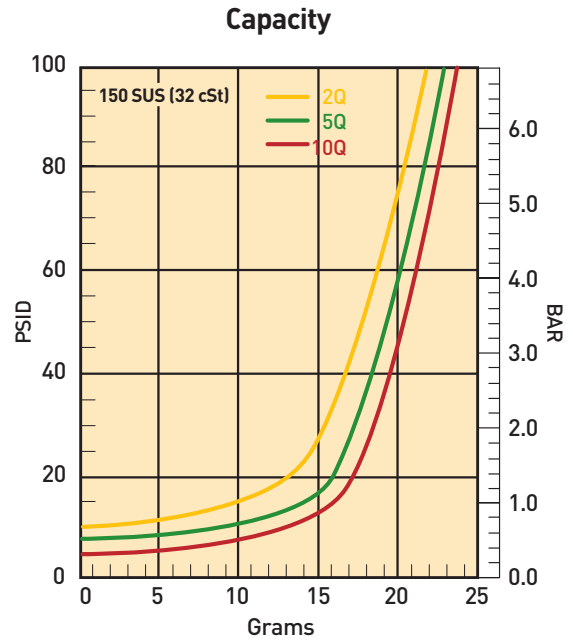
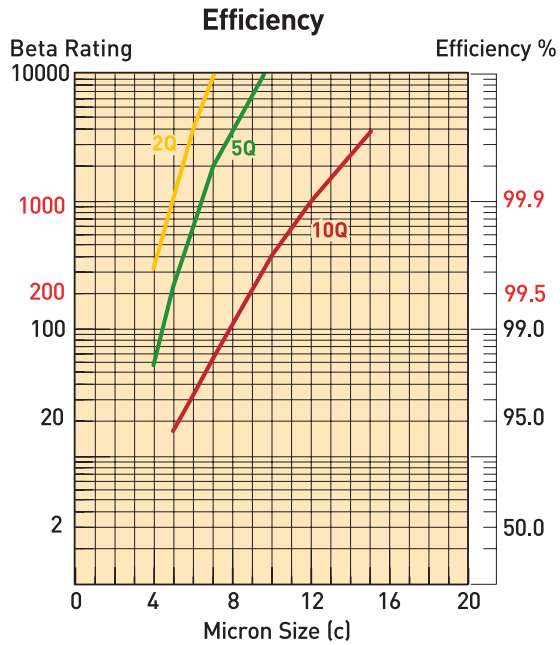

\*High Collapse Correction Factor:  
 "QH" Elements (2000 psid) = 1.4 times reported loss

Results typical from Multi-pass tests run per test standard ISO 16889 @ 25 gpm to 50 psid terminal - 10 mg/L BUGL.

Note: During reverse flow,  $\Delta P$  is 20 psid at max. flow.

# WPF Series

## WPF3 Element Performance

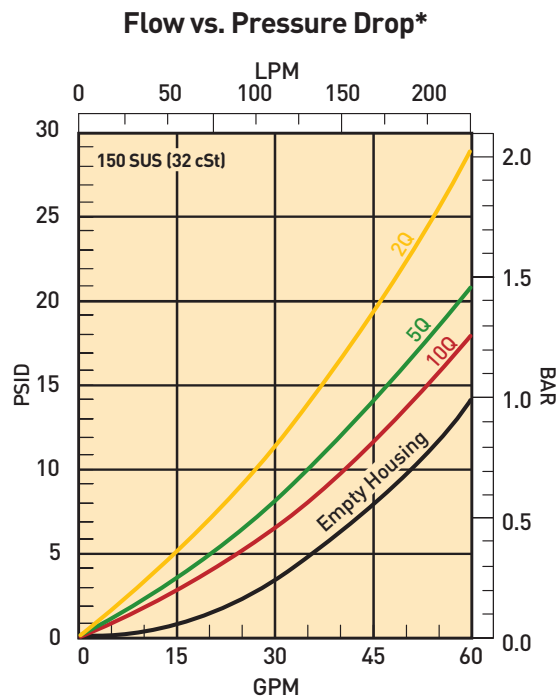
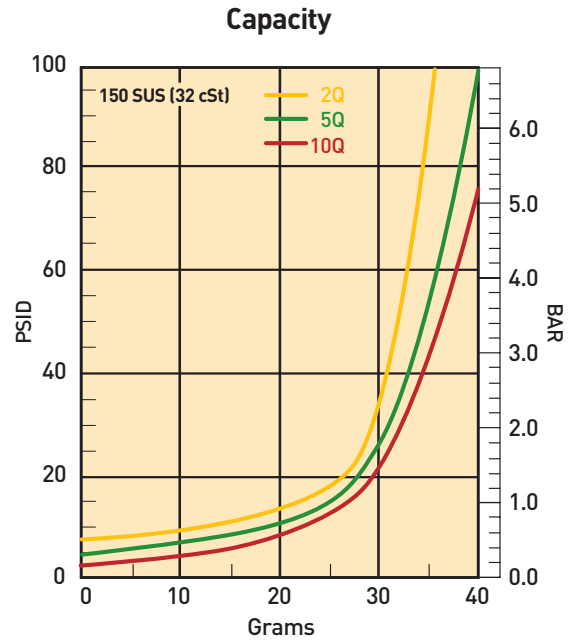
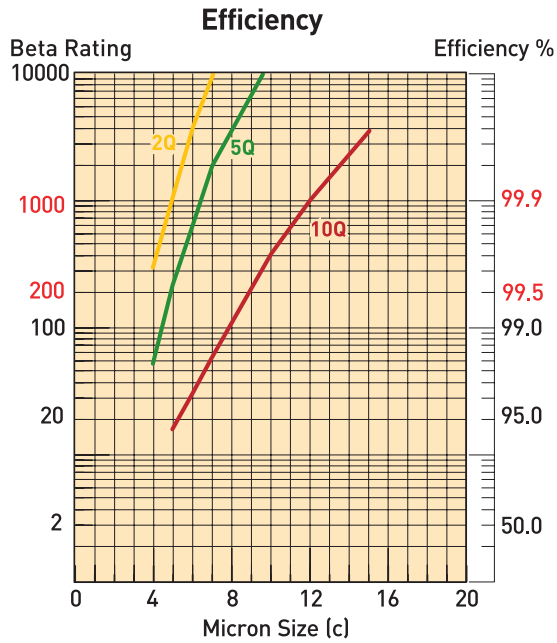

\*High Collapse Correction Factor:  
 "QH" Elements (2000 psid) = 1.4 times reported loss

Results typical from Multi-pass tests run per test standard ISO 16889 @ 45 gpm to 50 psid terminal - 10 mg/L BUGL.

Note: During reverse flow,  $\Delta P$  is 20 psid at max. flow.

# WPF Series

## WPF4 Element Performance

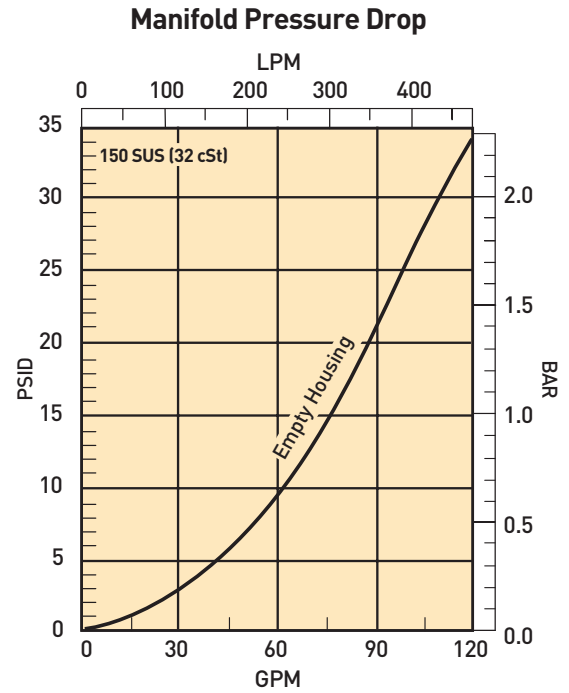
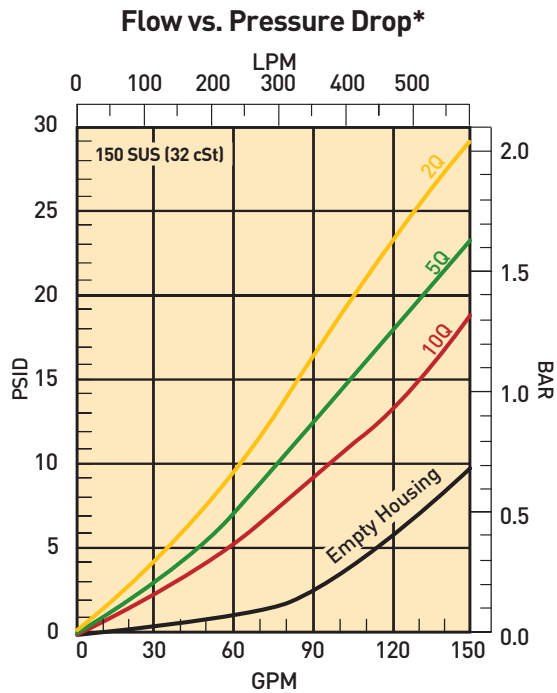
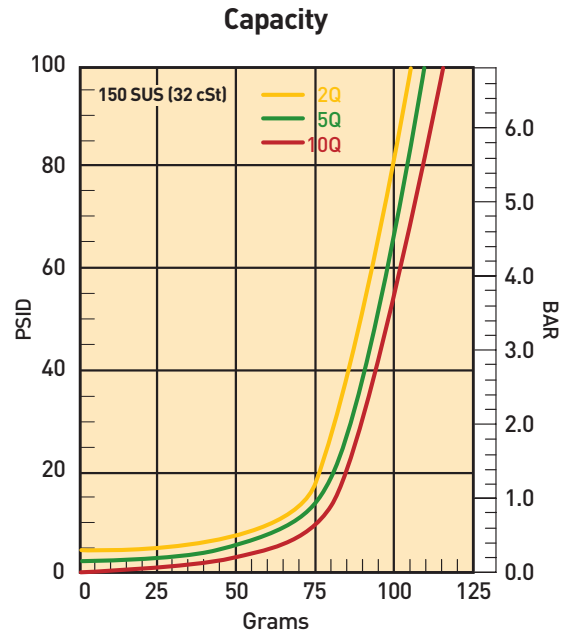
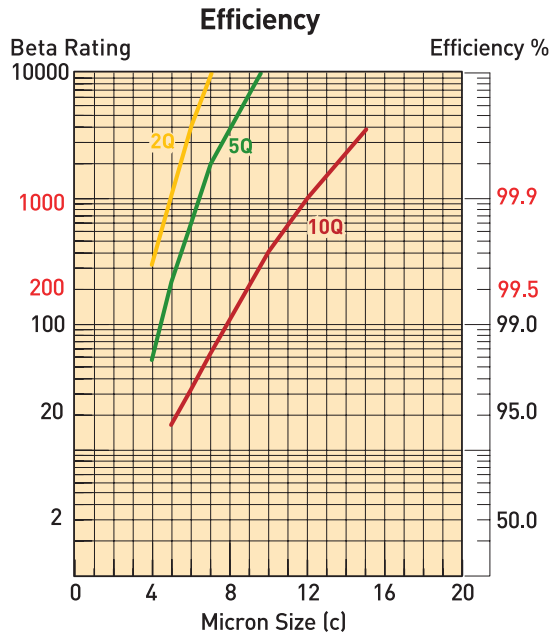

\*High Collapse Correction Factor:  
 "QH" Elements (2000 psid) = 1.4 times reported loss

Results typical from Multi-pass tests run per test standard ISO 16889 @ 90 gpm to 50 psid terminal - 10 mg/L BUGL.

Note: During reverse flow,  $\Delta P$  is 20 psid at max. flow.



# WPF Series

## WPF5 Element Performance

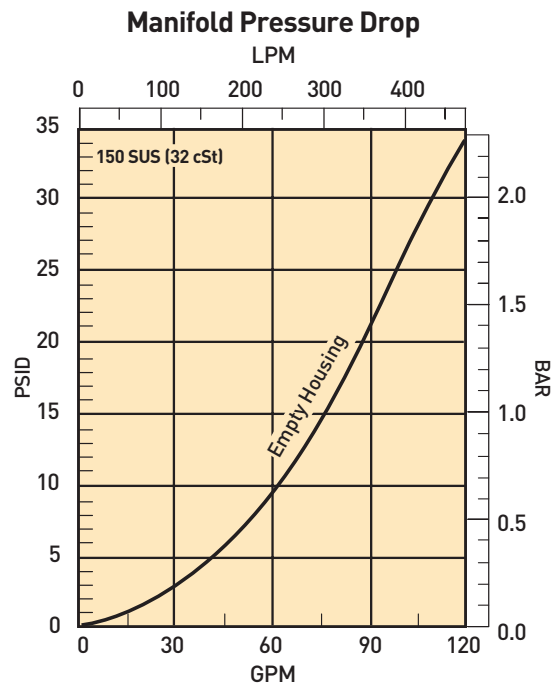
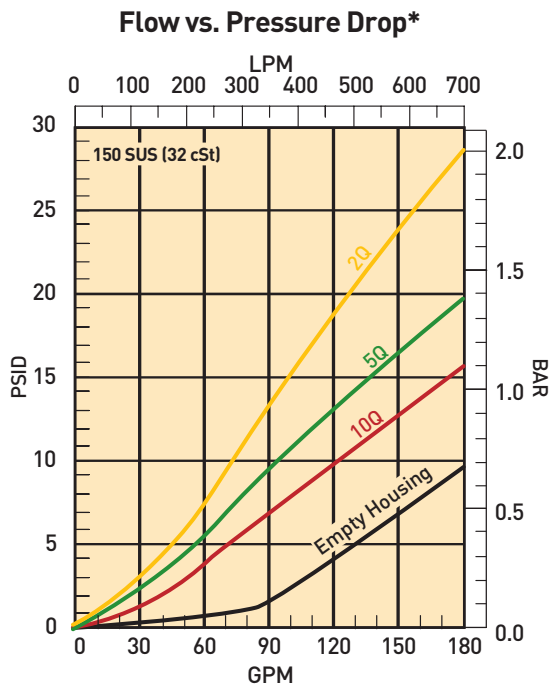
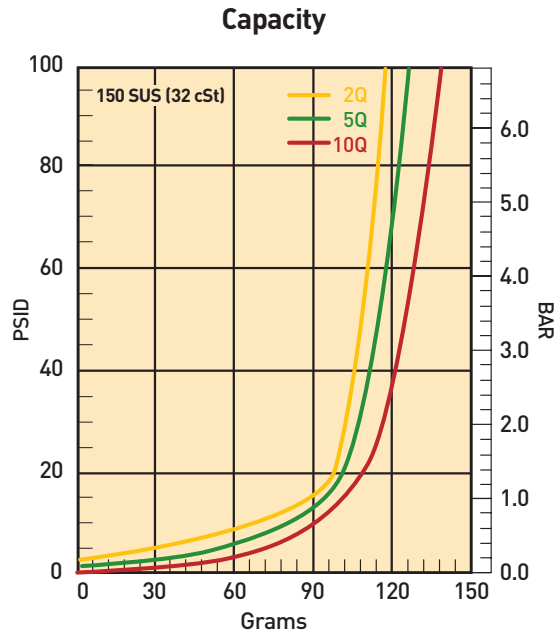
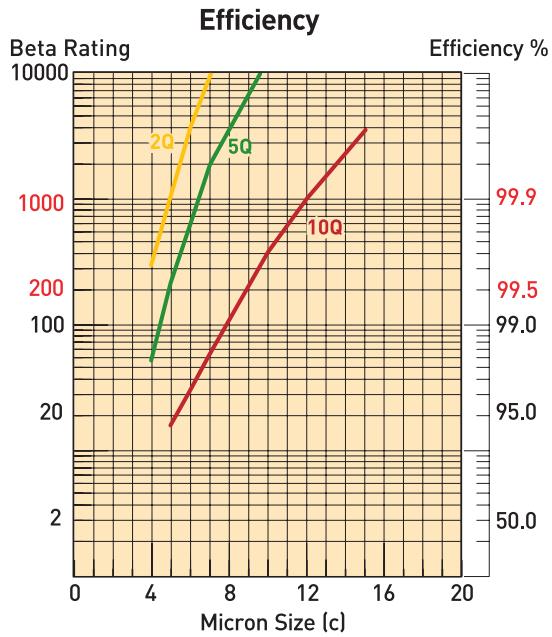

\*High Collapse Correction Factor:  
 "QH" Elements (2000 psid) = 1.4 times reported loss

Results typical from Multi-pass tests run per test standard ISO 16889 @ 100 gpm to 50 psid terminal - 10 mg/L BUGL.

Note: During reverse flow,  $\Delta P$  is 20 psid at max. flow.

# WPF Series

## Specifications

**Maximum Allowable Operating Pressure (MAOP):**

7000 psi (483 bar)

**Rated Fatigue Pressure:**

6000 psi (414 bar)

**Design Safety Factor: 3:1**

**Operating Temperatures:**

-15°F (-26°C) to 250°F (135°C)

**Element Collapse Rating:**

**Standard: 300 psi (21 bar)**

**High Collapse: 2000 psi (138 bar)**

**Materials:**

Head: SG Iron

Bowl: Steel

Indicator: Stainless Steel

with Plastic Connectors

**Weights:**

WPF1 9 lbs. (4.1 kg)

WPF2 13 lbs. (5.9 kg)

WPF3 21 lbs. (9.5 kg)

WPF4 45 lbs. (20.4 kg)

WPF5 67 lbs. (30.4 kg)

Drawings are for reference only.  
Contact factory for current version.

**T-PORT DIMENSIONS mm (inch)**

Filter Model	A	B	C	D	E	F	G	H	I	J	K	L	M
WPF1	70 (2.76)	180 (7.09)	69.5 (2.74)	23 (.91)	15 (.59)	27 (1.06)	60 (2.36)	30 (1.18)	90 (3.54)	92 (3.62)	46 (1.81)	30 (1.18)	15 (.59)
WPF2	79 (3.11)	293 (11.53)	75 (2.95)	32 (1.26)	26 (1.02)	30 (1.18)	80 (3.15)	40 (1.57)	98 (3.86)	110 (4.33)	55 (2.17)	40 (1.57)	20 (.78)
WPF3	88 (3.47)	345 (13.58)	93 (3.66)	40 (1.57)	29 (1.14)	35 (1.38)	90 (3.54)	55 (2.17)	120 (4.72)	126 (4.96)	63 (2.48)	45 (1.77)	27.5 (1.08)
WPF4	100 (3.94)	445 (17.52)	128 (5.04)	49 (1.93)	39 (1.54)	48 (1.89)	120 (4.72)	50 (1.97)	160 (6.30)	163 (6.42)	81.5 (3.21)	60 (2.36)	25 (.98)
WPF5	100 (3.94)	561 (22.09)	128 (5.04)	61 (2.40)	51 (2.01)	48 (1.89)	140 (5.51)	80 (3.15)	160 (6.30)	183 (7.20)	91.5 (3.60)	70 (2.76)	40 (1.57)

### T-Port

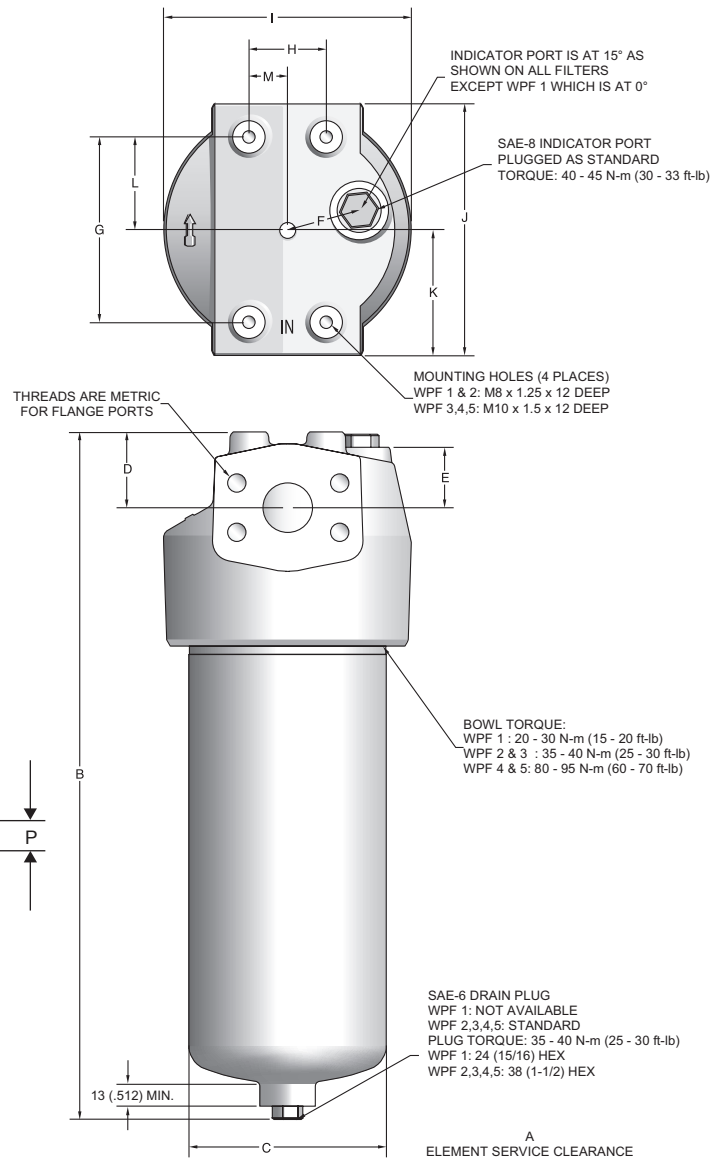

Flange Size	N: Thread & Depth	O	P	Q	R	S
3/4"	.750"	.937"	.469"	2.000"	1.000"	.750"
1"	1.000"	1.093"	.546"	2.250"	1.125"	1.000"
1-1/4"	1.250"	1.250"	.625"	2.625"	1.312"	1.250"
1-1/2"	1.500"	1.437"	.719"	3.125"	1.563"	1.500"

# WPF Series

## Specifications

### Maximum Allowable Operating Pressure (MAOP):

7000 psi (483 bar)

### Rated Fatigue Pressure:

6000 psi (414 bar)

### Design Safety Factor: 3:1

### Operating Temperatures:

-15°F (-26°C) to 250°F (135°C)

### Element Collapse Rating:

Standard: 300 psi (21 bar)

High Collapse: 2000 psi (138 bar)

### Materials:

Head: SG Iron

Bowl: Steel

Indicator: Stainless Steel  
with Plastic Connectors

### Weights:

WPF2 18 lbs. (8.2 kg)

WPF4 63 lbs. (28.6 kg)

WPF5 70 lbs. (31.7 kg)

Drawings are for reference only.  
Contact factory for current version.

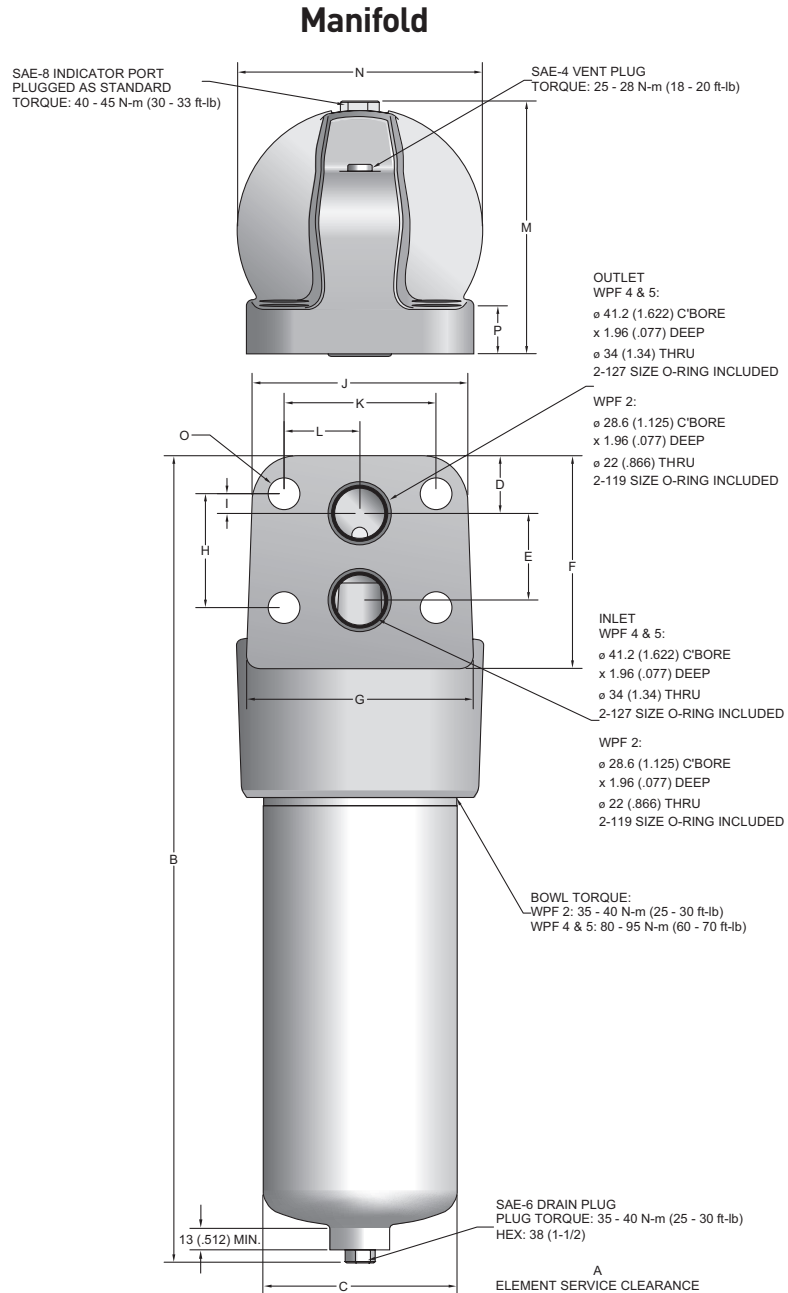

### MANIFOLD DIMENSIONS mm (inch)

Filter Model	A	B	C	D	E	F	G	H	I	J	K	L	M	N	O	P
WPF2	79 (3.11)	343(13.50)	75 (2.95)	24 (.94)	39 (1.53)	95 (3.74)	116 (4.57)	50 (1.97)	6 (.24)	110 (4.33)	80 (3.15)	40 (1.57)	110 (4.33)	121 (4.76)	17 (.67)	30 (1.18)
WPF4	100 (3.94)	532 (20.94)	128 (5.04)	38 (1.50)	57 (2.24)	140 (5.51)	150 (5.91)	75 (2.95)	13 (.51)	142 (5.59)	100 (3.94)	50 (1.97)	166.5 (6.56)	161 (6.34)	21 (.83)	31.7 (1.25)
WPF5	100 (3.94)	627 (24.69)	128 (5.04)	38 (1.50)	57 (2.24)	140 (5.51)	150 (5.91)	75 (2.95)	13 (.51)	142 (5.59)	100 (3.94)	50 (1.97)	166.5 (6.56)	161 (6.34)	21 (.83)	31.7 (1.25)

# WPF Series

## Indicator Specifications

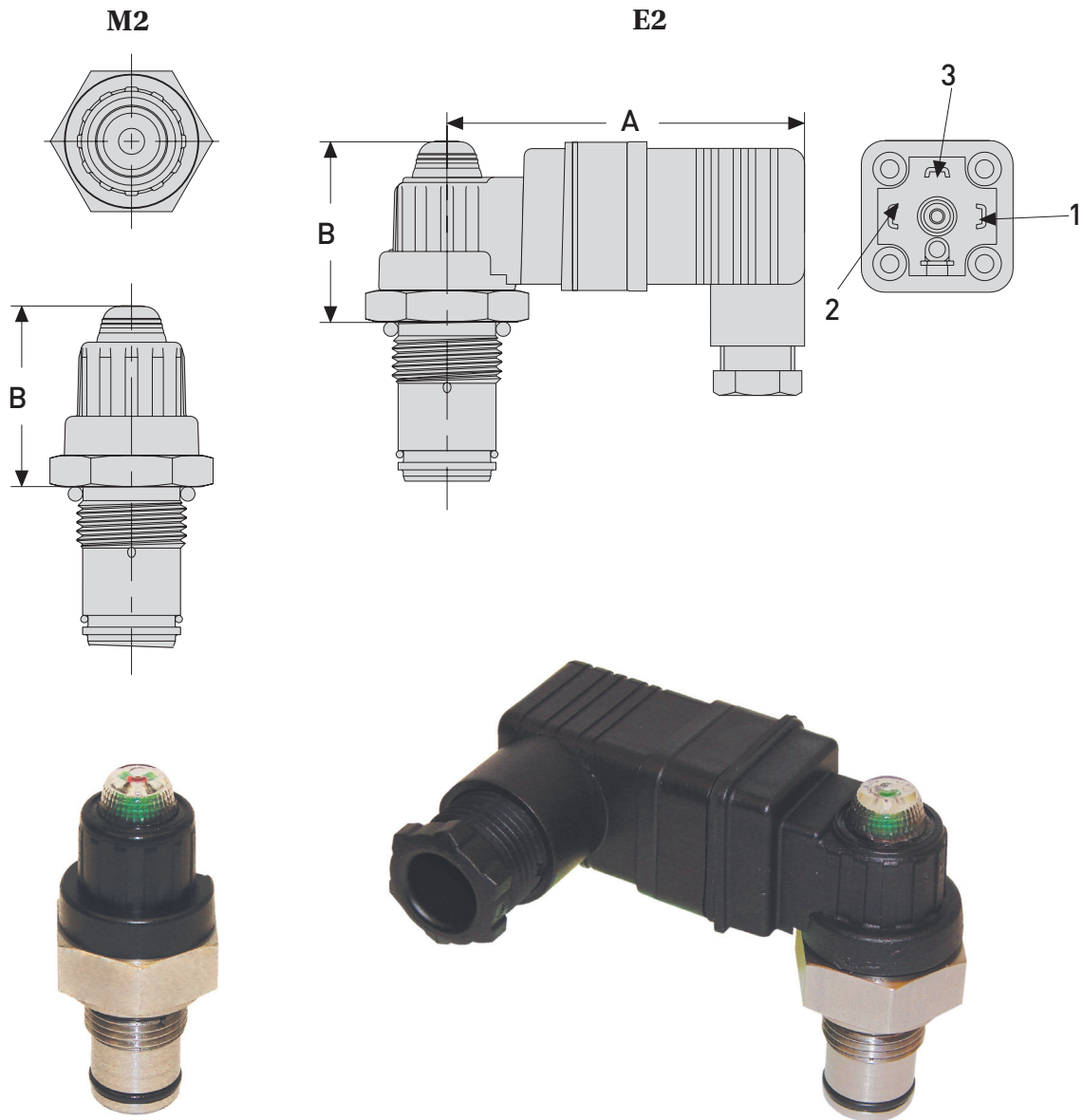

Torque: 30-33 ft-lb (40-45 N-m)  
Indicator setting: 50 psid

### INDICATOR DIMENSIONS mm (inch)

Option	Description	Connection/Power	Wiring	"A"	"B"
M2	Visual Auto Reset	N/A	N/A	N/A	49 (1.73)
E2	Electrical - Visual	Din 43650 3 Pole +Earth 5A@125/250 VAC, 3A@28VDC	Pin 1 - Common Pin 2 - Normally Closed Pin 3 - Normally Open	73.7 (2.90)	54 (2.13)

# WPF Series

## Service & Maintenance Instructions

- 1 Stop system power and vent captive pressure.
- 2 Drain filter assembly.
- 3 Remove bowl and element assembly.
- 4 Push down to squeeze tangs and lift element.
- 5 Twist to remove core.
- 6 Retain reusable core.
- 7 Discard used element.
- 8 Insert reusable core into new element until it snaps.
- 9 Push element assembly into bowl, snap tangs.
- 10 Inspect o-ring and anti-extrusion ring.
- 11 Install bowl with new element.
- 12 Torque bowl, vent and drain plugs.
- 13 Power up and inspect.



# WPF Series

## Parts List

### T-Port

Index	Part Description	Part Number
1	WPF1 Head SAE-8	940986
	WPF2 Head 3/4" Flange	940989
	WPF2 Head SAE-12	940988
	WPF3 Head 1" Flange	940992
	WPF3 Head SAE-16	940991
	WPF4 Head 1-1/4" Flange	940923
	WPF4 Head SAE-20	940924
	WPF5 Head 1-1/2" Flange	940773
	WPF5 Head SAE-24	940921
2	Element	See chart on page 158
3	WPF1 Reusable Core	941175
	WPF2 Reusable Core	941176
	WPF3 Reusable Core	941177
	WPF4 Reusable Core	941178
	WPF5 Reusable Core	941179
4	WPF1 Bowl O-ring	V92141
	WPF2 Bowl O-ring	V92144
	WPF3 Bowl O-ring	V92042
	WPF4 Bowl O-ring	V92157
	WPF5 Bowl O-ring	V92157
5	WPF1 Anti-extrusion Ring	941185
	WPF2 Anti-extrusion Ring	934798
	WPF3 Anti-extrusion Ring	941186
	WPF4 Anti-extrusion Ring	941187
	WPF5 Anti-extrusion Ring	941187
6	WPF1 Bowl	941153
	WPF2 Bowl	941154
	WPF3 Bowl	942300
	WPF4 Bowl	941156
	WPF5 Bowl	941157
7	Drain Plug	934320
8	Indicator Plug	941172
9	Electrical Indicator	941173
10	Visual Indicator	941174
11	Name Plate	920928
Not Shown	Drive Screw (2 required)	900028

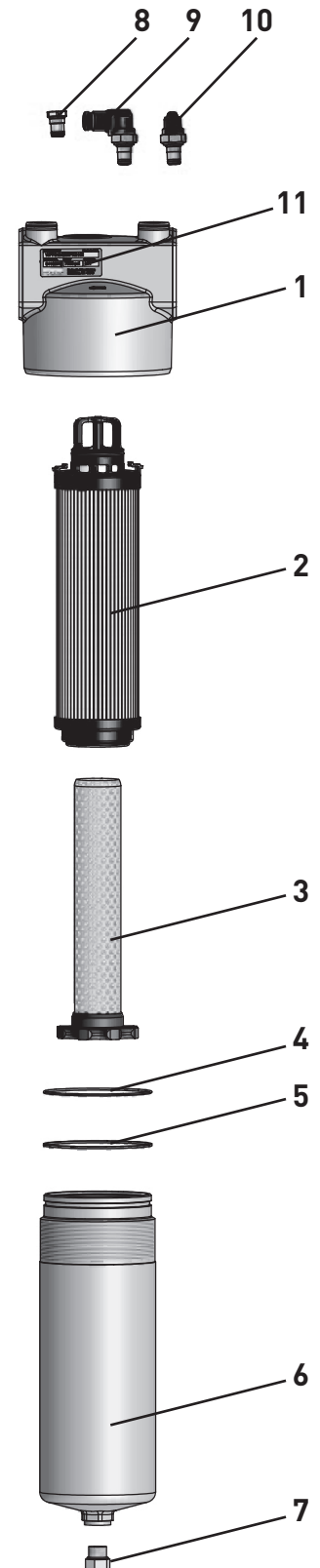

# WPF Series

## Parts List

### Manifold

Index	Part Description	Part Number
1	WPF2 Manifold Mount Head	941273
	WPF4 Manifold Mount Head	940982
	WPF5 Manifold Mount Head	940982
2	WPF2 Manifold Mount O-rings (2 req'd)	V92119
	WPF4 Manifold Mount O-rings (2 req'd)	V92127
	WPF5 Manifold Mount O-rings (2 req'd)	V92127
3	Element	See chart on page 158
4	WPF2 Reusable Core	941176
	WPF4 Reusable Core	941178
	WPF5 Reusable Core	941179
5	WPF2 Bowl O-ring	V92144
	WPF4 Bowl O-ring	V92157
	WPF5 Bowl O-ring	V92157
6	WPF2 Anti-extrusion Ring	934798
	WPF4 Anti-extrusion Ring	941187
	WPF5 Anti-extrusion Ring	941187
7	WPF2 Bowl	941154
	WPF4 Bowl	941156
	WPF5 Bowl	941157
8	Drain Plug	934320
9	Vent Plug	928882
10	WPF Indicator Plug	941172
11	Electrical Indicator	941173
12	Visual Indicator	941174
Not Shown	Name Plate	920928
Not Shown	Drive Screw (2 required)	900028

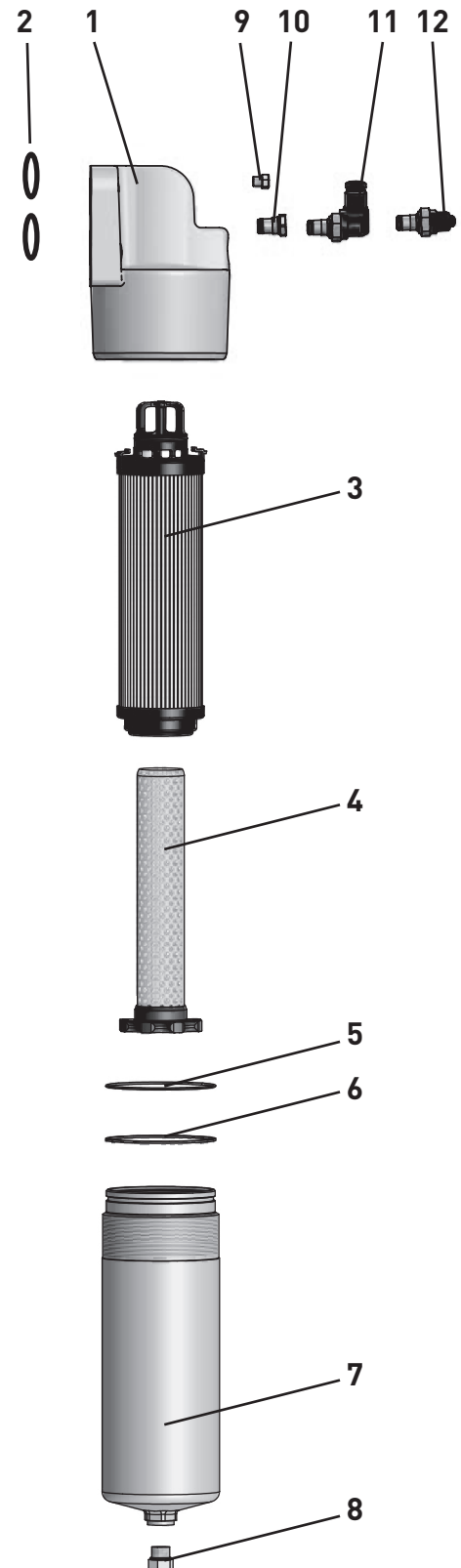

# WPF Series

## How to Order

Select the desired symbol (in the correct position) to construct a model code.

Example:

BOX 1	BOX 2	BOX 3	BOX 4	BOX 5	BOX 6	BOX 7	BOX 8
WPF	2	10QE	V	M2	K	S12	1

BOX 1: Filter Series	
Symbol	Description
WPF	High Pressure Filter

BOX 2: Model	
Symbol	Description
1	1/2" Nominal ports
2	3/4" Nominal ports
3	1" Nominal ports
4	1 1/4" Nominal ports
5	1 1/2" Nominal ports

BOX 3: Media Code	
Symbol	Description
02QE	Ecoglass III (bypass only)
05QE	Ecoglass III (bypass only)
10QE	Ecoglass III (bypass only)
	<b>High Collapse</b>
02QH	Microglass III (no bypass only)
10QH	Microglass III (no bypass only)

BOX 4: Seals	
Symbol	Description
B	Nitrile (NBR)
E	Ethylene Propylene
V	Fluorocarbon (FKM)

BOX 5: Indicator	
Symbol	Description
P	Plugged indicator port
M2	Visual Automatic Reset
E2	Electrical/ Visual (DIN43650 style connection)
Note: When the "M2" or "E2" option is selected, the indicator port is plugged and the indicator is shipped as a loose part.	

BOX 6: Bypass	
Symbol	Description
K	50 PSID (3.5 bar)
X	No Bypass and No Indicator (port plugged)
Note: When an indicator and no bypass ("2" in Box 8) is selected, the indicator setting is 50 psid (3.5 bar).	

Please note the bolded options reflect standard options with a reduced lead-time. Consult factory on all other lead-time options.

BOX 7: Ports	
Symbol	Description
	<b>WPF1</b>
S08	SAE-8 Ports
	<b>WPF2</b>
S12	SAE-12 Ports
Y12	3/4" SAE Code 62 Flange face
X12	Manifold
	<b>WPF3</b>
S16	SAE-16 Ports
Y16	1" SAE Code 62 Flange face
	<b>WPF4</b>
S20	SAE-20 Ports
Y20	1 1/4" SAE Code 62 Flange face
X20	Manifold
	<b>WPF5</b>
S24	SAE-24 Ports
Y24	1 1/2" SAE Code 62 Flange face
X24	Manifold

BOX 8: Options	
Symbol	Description
1	<b>With Bypass</b> (for use with standard element only)
2	No Bypass (for use with high collapse element only)

### Replacement Elements:

	Media	WPF1	WPF2	WPF3	WPF4	WPF5
Standard Collapse (300 psid/21 bar)	Ecoglass III, 02QE	941029Q	941032Q	941035Q	941038Q	941041Q
	Ecoglass III, 05QE	941030Q	941033Q	941036Q	941039Q	941042Q
	Ecoglass III, 10QE	941031Q	941034Q	941037Q	941040Q	941043Q
High Collapse (2000 psid/138 bar)	Microglass III, 02QH	941044Q	941046Q	941048Q	941050Q	941052Q
	Microglass III, 10QH	941045Q	941047Q	941049Q	941051Q	941053Q

Global products as identified are offered worldwide through all Parker locations and utilize a common ordering code.

