



Bulletin #HY08-1113-B1/NA

WaveScale

Effective: November, 2002

Supersedes: None

Linear Displacement Transducers



 **WARNING**

FAILURE OR IMPROPER SELECTION OR IMPROPER USE OF THE PRODUCTS AND/OR SYSTEMS DESCRIBED HEREIN OR RELATED ITEMS CAN CAUSE DEATH, PERSONAL INJURY AND PROPERTY DAMAGE.

This document and other information from Parker Hannifin Corporation, its subsidiaries and authorized distributors provide product and/or system options for further investigation by users having technical expertise. It is important that you analyze all aspects of your application, including consequences of any failure and review the information concerning the product or system in the current product catalog. Due to the variety of operating conditions and applications for these products or systems, the user, through its own analysis and testing, is solely responsible for making the final selection of the products and systems and assuring that all performance, safety and warning requirements of the application are met.

The product described herein, including without limitation, product features, specifications, designs, availability and pricing, are subject to change by Parker Hannifin Corporation and its subsidiaries at any time without notice.

Offer of Sale

The items described in this document are hereby offered for sale by Parker Hannifin Corporation, its subsidiaries or its authorized distributors. This offer and its acceptance are governed by provisions stated on a separate page of this catalog in the document entitled "Offer of Sale".

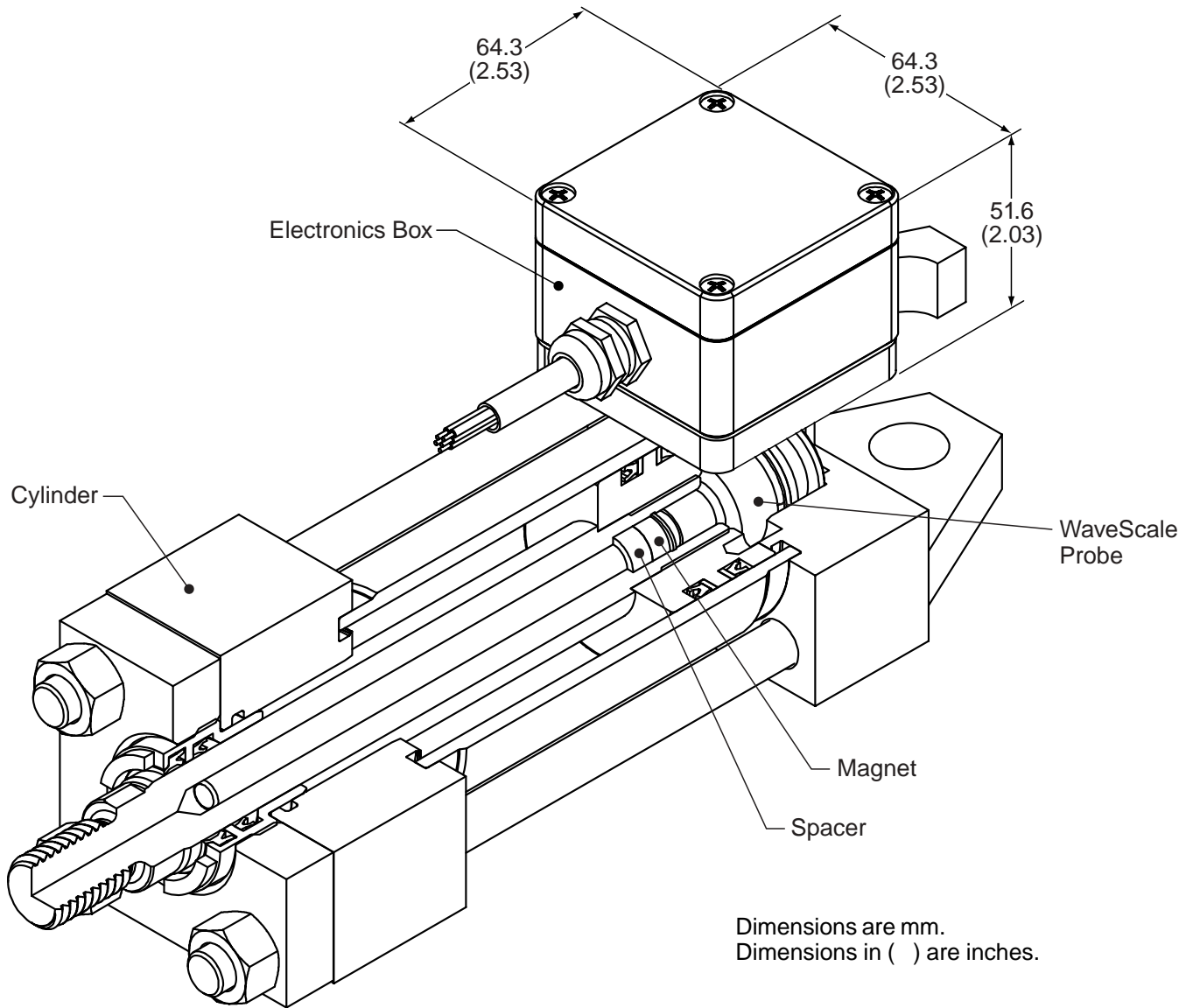

Cutaway View

This cylinder meets standard NFPA heavy duty hydraulic cylinder dimensions, 2" to 6" bore with a male piston rod end. The main advantage is no false stage is required for cap mounts.

The overall length of the cylinder is not increased.

How to Order:

1. Specify the complete Parker Cylinder Model Number from Table A and from Cylinder Catalog.
2. Specify the 6 digit Valve and Feedback code for 2HX cylinders.

Basic Model Numbers

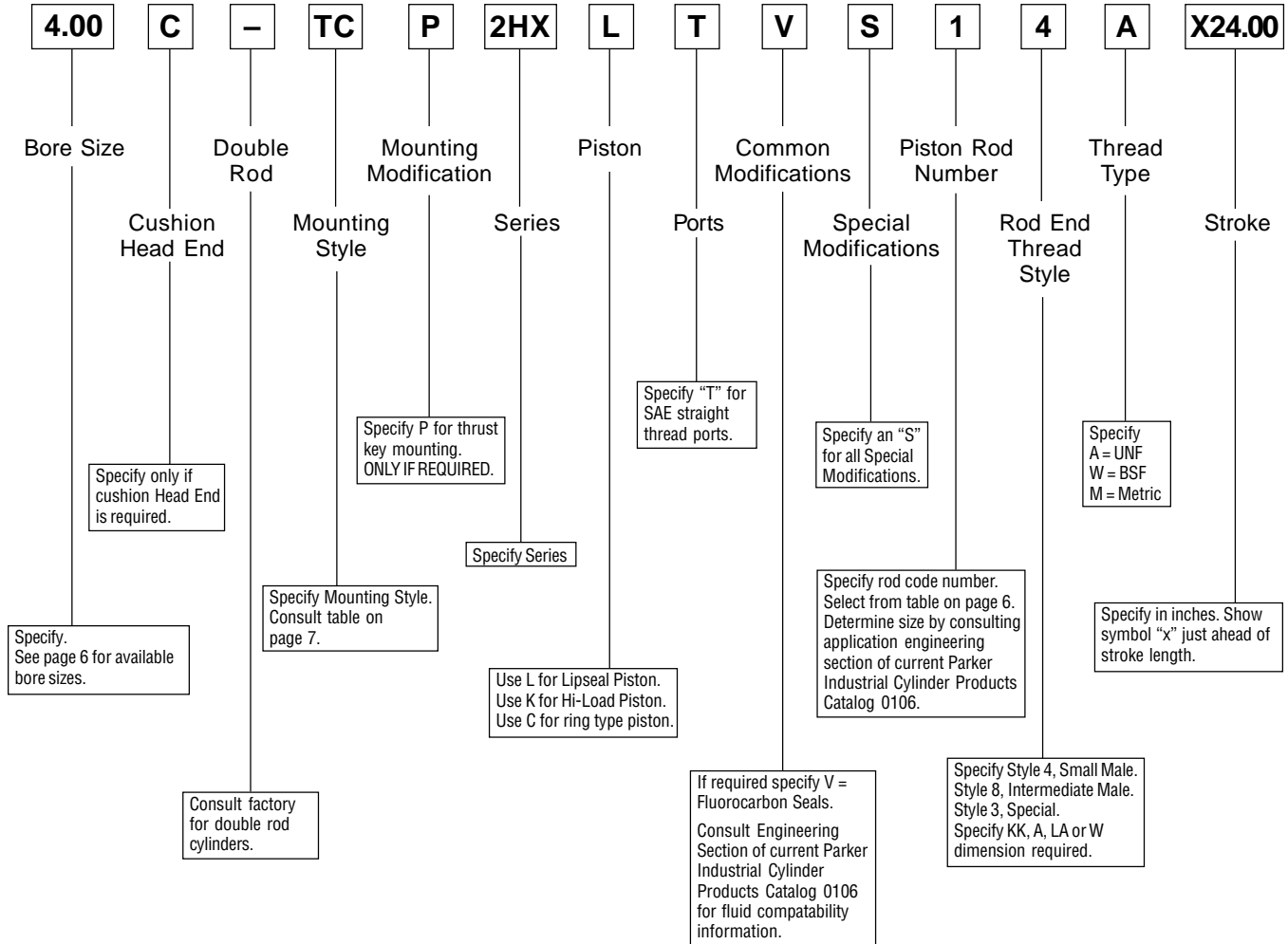

Note: Cap end cushion not available.

Consult current 2H section of Parker Industrial Cylinder Products Catalog 0106 for complete dimensions, specifications and model number information.

Valve and Feedback Codes

(required for 2HX ordering)

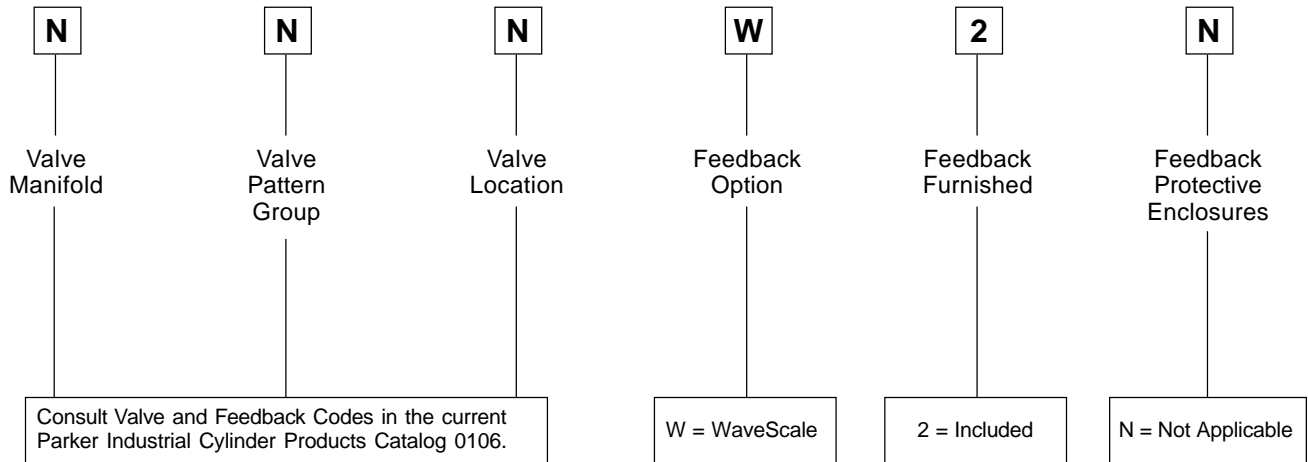

Consult current Parker Industrial Cylinder Products Catalog 0106 for complete model number and specifications.

Output Available

- 0-10 VDC (standard)**
- 4-20 mA or 20-4 mA (grounded)
- 0-20 mA or 20-0 mA (grounded)
- Digital Start/Stop
- Digital pulse-width modulation
- State External or Internal Interrogation.
- Refer to Chart A and B (right) for circulation count.

*Can be wired for 10-0 Vdc. See Standard Specifications.

Charts A and B (right) apply to sensors with pulse-width modulated (PWM) outputs. Chart A defines the circulation count required to reach varying levels of resolution. Chart B defines maximum stroke length based on the circulation count (applies only to sensors with internal interrogation).

Chart A

Circulation Count vs. Resolution for PWM Outputs (based on a 28 MHz counter)	
Resolution	Circulation Count*
0.00026 (0.0066mm)	15
0.0005 (0.0127mm)	8
0.001 (0.025mm)	4
0.002 (0.051mm)	2
0.004 (0.102mm)	1

Chart B

Maximum Stroke per Circulation Count for PWM Output w/Internal Interrogation	
Stroke	Maximum Circulation Count
≤ 84 inches (2134mm)	15
> 84.1 inches (2136mm)	1

* Maximum circulation count is limited by stroke length for sensors configured for internal interrogation. (Refer to Chart B for stroke length limitations.)

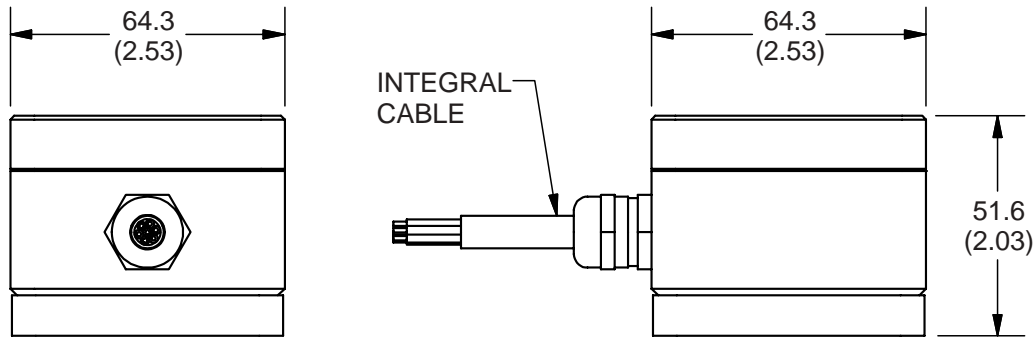

LDT Technical Section

The WaveScale Actuator is the most versatile actuator that we offer. Utilizing the Temposonics L Series feedback device, there are three distinct outputs available to suit most applications. Velocity is limited primarily by the limits of mechanical components outside of the actuator,

although position update time can affect the system ramp-down. The WaveScale Actuator is the industry favorite in tough, rugged machinery applications. A key advantage is the absolute position output which is not lost if there is a power failure.

Magnetostriction

In a WaveScale position sensor, a pulse is induced in a specially-designed magnetostrictive waveguide by the momentary interaction of two magnetic fields. One field comes from a movable magnet which passes along the outside of the sensor tube, the other field comes from a current pulse or interrogation pulse launched along the waveguide. The interaction between the two magnetic fields produces a strain pulse, which travels at sonic speed along the waveguide until the pulse is detected at the head of the sensor. The position of the magnet is determined with high precision by measuring the elapsed time between the launching of the electronic interrogation pulse and the arrival of the strain pulse. As a result, accurate non-contact position sensing is achieved with absolutely no wear to the sensing components.

An average of 200 ultrasonic strain pulses are launched for every reading. With so many readings taken for each position, vibration and shock have negligible effect on the readings. The transducer assembly is shielded to eliminate interference caused by electromagnetic fields in the radio frequency range. In addition, static magnetic fields of several hundred gauss must get as close as 3/16" from the protective tube before any interference in transducer operation occurs.

Features

- High immunity to shock and vibration
- Single voltage input +24Vdc
- 3000 psi operating pressure
- Standard strokes up to 100"
- Multiple outputs
 - 0 to 10 VDC forward and reverse acting, grounded (forward acting standard)
 - 4-20 mA forward and reverse acting, grounded
 - 0-20 mA forward and reverse acting, grounded
 - Digital Start/Stop
 - Digital pulse-width modulation

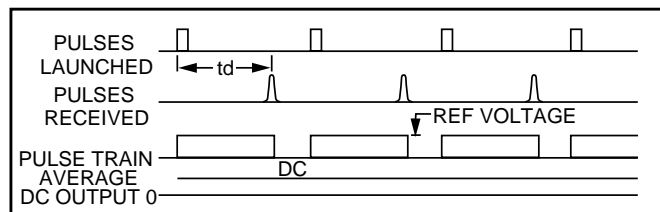

Feedback Accuracy

The accuracy of a given feedback device is a composite of a number of factors, the most important of which are:

Resolution – The smallest movement of the device that will produce a measurable output.

Non-Linearity – The deviation of the signal from a straight line output.

Repeatability – The maximum deviation of output signal for repeated positioning to a fixed point.

Hysteresis – The deviation of the signal when approaching a fixed point from opposite directions.

Temperature Coefficient – The shift in output due to temperature change. This is a combination of the effect of temperature on the cylinder, the transducer and the electronics.

These factors which are normally additive refer to the feedback device itself. The performance achieved by a given system depends on the various factors such as system stiffness, valve performance, friction, temperature variation, and backlash in mechanical linkages to the cylinder.

In the case of front flange mounted cylinders, the stretch of the cylinder due to hydraulic pressure changes may affect position repeatability and system performance.

Standard Specifications

Parameter	Specification
Resolution:	<i>Analog:</i> Infinite <i>Digital:</i> 1 ÷ [gradient x crystal freq. (mHz) x circulation]
Non-Linearity:	±0.02% or ±0.10 mm (±0.004 in.), whichever is greater Minimum absolute linearity and varies with sensor model. Non-linearity increases with multiple circulations.
Repeatability:	Equal to resolution
Hysteresis:	<0.02 mm (0.0008 in.)
Outputs:	<i>Analog:</i> Voltage or Current <i>Digital:</i> Start/Stop or PWM
Measuring Range:	<i>Analog:</i> 25 to 2540 mm (1 to 100 in.) <i>Digital:</i> 25 to 2540 mm (1 to 100 in.)
Operating Voltage:	+24 Vdc (±10%)
Power Consumption:	100 mA Typical
Operating Temperature:	-40 to 85°C (-40 to 185°F)

EMC Test*:	DIN IEC 801-4, Type 4, CE Qualified; DIN EN 50081-1 (Emissions), DIN EN 50082-2 (Immunity)
Shock Rating:	100 g (single hit)/IEC standard 68-2-27 (survivability)
Vibration Rating:	5 g/10-150 Hz/IEC standard 68-2-6
Adjustability:	Field adjustable zero and span to 5% of active stroke length <i>(for analog sensors only)</i>
Update Time:	<i>Analog:</i> ≤1 ms (Typical) <i>Digital:</i> Minimum = [Stroke (specified in inches) + 3] x 9.1 μs
Operating Pressure:	210 bar (3000 psi) static

The above specifications for analog sensors are assuming that output ripple is averaged by the measuring device as with any typical analog device. Specifications are subject to change without notice. Consult the factory for specifications critical to your needs.

Connection Types:

Integral Connector D6
Integral Cable with Hanging D6 Connector
Integral Cable with Pigtail Termination

Analog Output:
(Voltage or Current)

Pin No.	Wire Color	Function
1	Gray	0 to 10 Vdc, 4 to 20 mA, 0 to 20 mA
2	Pink	Return for Pin 1
3	Yellow	10 to 0 Vdc, 20 to 4 mA, or 20 to 0 mA
4	Green	Return for Pin 3
5	Red or Brown	Customer Supplied Power (+24 Vdc)
6	White	DC Ground

Integral or Hanging Connector (D6 Male)
(As viewed from end of sensor)

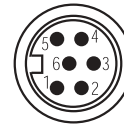

Digital Output:
(PWM or Start/Stop)

Pin No.	Wire Color	Function
1	Gray	(-) Gate for PWM, (-) Stop for Start/Stop
2	Pink	(+) Gate for PWM, (+) Stop for Start/Stop
3	Yellow	(+) Interrogation for PWM, (+) Start for Start/Stop
4	Green	(-) Interrogation for PWM, (-) Start for Start/Stop
5	Red or Brown	Customer Supplied Power (+24 Vdc)
6	White	DC Ground

Connection Type:

Integral Cable with Hanging MS Connector

Analog Output:
(Voltage or Current)

Pin No.	Wire Color	Function
A	White	DC Ground
B	Drain	Case Ground
C	Gray	Return for Pin D
D	Pink	0 to 10 Vdc, 4 to 20 mA, or 0 to 20 mA
E	Red or Brown	Customer Supplied Power (+24 Vdc)
F	-	No Connection
G	Yellow	10 to 0 Vdc, 20 to 4 mA, or 20 to 0 mA
H	Green	Return for Pin G
J	-	No Connection
K	-	No Connection

Hanging Connector (MS Male)

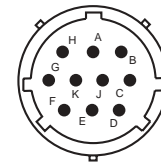

Digital Output:
(PWM or Start/Stop)

Pin No.	Wire Color	Function
A	White	DC Ground
B	Drain	Case Ground
C	Gray	(-) Gate for PWM, (-) Stop for Start/Stop
D	Pink	(+) Gate for PWM, (+) Stop for Start/Stop
E	Red or Brown	Customer Supplied Power (+24 Vdc)
F	-	No Connection
G	-	No Connection
H	-	No Connection
J	Yellow	(+) Interrogation for PWM (+) Start for Start/Stop
K	Green	(-) Interrogation for PWM

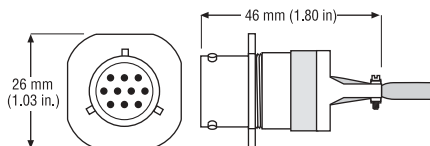

Hanging Connector (MS male)

CAUTION!

- 1) When wiring Tempsonics L Series sensors, **do not connect DC ground to the cable shield or drain wire.**
- 2) For single-ended interrogation, the unused interrogation lead must be connected to DC ground (single-ended interrogation is not recommended).
- 3) When using PWM with internal interrogation, both interrogation leads must be connected to DC ground.
- 4) Minimum load impedance for voltage outputs is 5KΩ.

The pressure rating is reduced on some bores and rod codes. The "W" dimension is increased for style 9 rod ends. Style 4 and 8 cannot be studded rod ends to have the "W" dimension as standard.

Envelope and Rod Dimensions

Bore	Rod Code	Rod Dia. MM	A	Style 4 KK	Style 8 CC	Add Stroke	4 to 1 Design Factor (PSI)*
						LB	
2	1	1	1 1/8	3/4-16	7/8-12	5 1/4	2300
	2	1 3/8	1 5/8	1-14	1 1/4-12	5 1/4	3000
2 1/2	1	1	1 1/8	3/4-16	7/8-12	5 3/8	1400
	2	1 3/4	2	1 1/4-12	1 1/2-12	5 3/8	3000
	3	1 3/8	1 5/8	1-14	1 1/4-12	5 3/8	3000
3 1/4	1	1 3/8	1 5/8	1-14	1 1/4-12	6 1/4	3000
	2	2	2 1/4	1 1/2-12	1 3/4-12	6 1/4	3000
	3	1 3/4	2	1 1/4-12	1 1/2-12	6 1/4	3000
4	1	1 3/4	2	1 1/4-12	1 1/2-12	6 5/8	3000
	2	2 1/2	3	1 7/8-12	2 1/4-12	6 5/8	3000
	3	2	2 1/4	1 1/2-12	1 3/4-12	6 5/8	3000
5	1	2	2 1/4	1 1/2-12	1 3/4-12	7 1/8	3000
	2	3 1/2	3 1/2	2 1/2-12	3 1/4-12	7 1/8	3000
	3	2 1/2	3	1 7/8-12	2 1/4-12	7 1/8	3000
	4	3	3 1/2	2 1/4-12	2 3/4-12	7 1/8	3000
6	1	2 1/2	3	1 7/8-12	2 1/4-12	8 3/8	3000
	2	4	4	3-12	3 3/4-12	8 3/8	3000
	3	3	3 1/2	2 1/4-12	2 3/4-12	8 3/8	3000
	4	3 1/2	3 1/2	2 1/2-12	3 1/4-12	8 3/8	3000

Bore	Rod Code	Rod Dia. MM	A	Style 9 KK	Style 9 W	Add Stroke	4 to 1 Design Factor (PSI)*
						LB	
2	1	1	1 1/8	3/4-16	1 7/8	5 1/4	2300
	2	1 3/8	1 5/8	1-14	2 9/16	5 1/4	3000
2 1/2	1	1	1 1/8	3/4-16	1 3/4	5 3/8	1400
	2	1 3/4	2	1 1/4-12	2 7/8	5 3/8	3000
	3	1 3/8	1 5/8	1-14	2 3/8	5 3/8	3000
3 1/4	1	1 3/8	1 5/8	1-14	1 3/4	6 1/4	3000
	2	2	2 1/4	1 1/2-12	2 5/8	6 1/4	3000
	3	1 3/4	2	1 1/4-12	3 1/4	6 1/4	3000
4	1	1 3/4	2	1 1/4-12	1 7/8	6 5/8	3000
	2	2 1/2	3	1 7/8-12	3 1/8	6 5/8	3000
	3	2	2 1/4	1 1/2-12	2 1/4	6 5/8	3000
5	1	2	2 1/4	1 1/2-12	1 3/4	7 1/8	3000
	2	3 1/2	3 1/2	2 1/2-12	3 1/8	7 1/8	3000
	3	2 1/2	3	1 7/8-12	2 5/8	7 1/8	3000
	4	3	3 1/2	2 1/4-12	3 1/8	7 1/8	3000
6	1	2 1/2	3	1 7/8-12	1 7/8	8 3/8	3000
	2	4	4	3-12	3 1/16	8 3/8	3000
	3	3	3 1/2	2 1/4-12	2 3/8	8 3/8	3000
	4	3 1/2	3 1/2	2 1/2-12	2 3/8	8 3/8	3000

All dimensions in the above tables are in inches.

* The 4:1 design factor is based on the tensile strength of the piston to rod connection.



Electronic Enclosure Positions

The standard location for the electronic enclosure is position #2. Reference the table below for locations that are not occupied by a mount or port.

Available Mounting and Electronic Enclosure Position

MOUNTING STYLE	DESCRIPTION	ELECTRONIC ENCLOSURE POSITION
TB	Head Tie Rods Extended	1,2,3,4
TC	Cap Tie Rods Extended	1,2,3,4
TD	Both Ends Tie Rods Extended	1,2,3,4
J	Head Rectangular Flange	1,2,3,4
JB	Head Square Flange	1,2,3,4
JJ	Head Rectangular	1,2,3,4
H	Cap Rectangular Flange	1,3 CF
HB	Cap Square Flange	CF
HH	Cap Rectangular	1,3 CF
C	Side Lug	1 CF
E	Centerline Lug	N/A
F	Side Tapped	1;2&4
CB	Side End Angles	1;2&4
G	Side End Lugs	1;2&4
BB	Cap Fixed Clevis	1,2,3,4
D	Head Trunnion	1,2,3,4
DB	Cap Trunnion	1,3 CF
DD	Intermediate Fixed Trunnion	1,3 CF
SB	Spherical Bearing	1,2,3,4

N/A = Not Available
 CF = Consult Factory

Envelope and Rod Dimensions

Thread Style 9

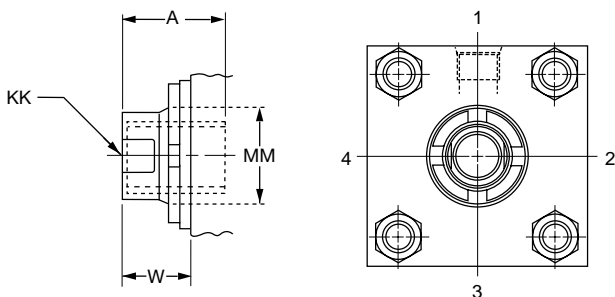

Thread Style 4 & 8

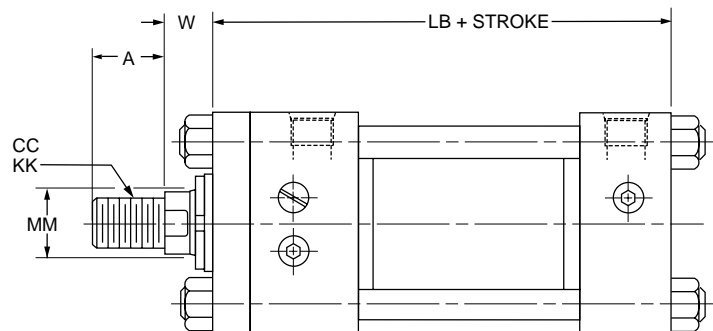

The items described in this document and other documents or descriptions provided by Parker Hannifin Corporation, its subsidiaries and its authorized distributors are hereby offered for sale at prices to be established by Parker Hannifin Corporation, its subsidiaries and its authorized distributors. This offer and its acceptance by any customer ("Buyer") shall be governed by all of the following Terms and Conditions. Buyer's order for any such item, when communicated to Parker Hannifin Corporation, its subsidiary or an authorized distributor ("Seller") verbally or in writing, shall constitute acceptance of this offer.

1. Terms and Conditions of Sale: All descriptions, quotations, proposals, offers, acknowledgments, acceptances and sales of Seller's products are subject to and shall be governed exclusively by the terms and conditions stated herein. Buyer's acceptance of any offer to sell is limited to these terms and conditions. Any terms or conditions in addition to, or inconsistent with those stated herein, proposed by Buyer in any acceptance of an offer by Seller, are hereby objected to. No such additional, different or inconsistent terms and conditions shall become part of the contract between Buyer and Seller unless expressly accepted in writing by Seller. Seller's acceptance of any offer to purchase by Buyer is expressly conditional upon Buyer's assent to all the terms and conditions stated herein, including any terms in addition to, or inconsistent with those contained in Buyer's offer. Acceptance of Seller's products shall in all events constitute such assent.

2. Payment: Payment shall be made by Buyer net 30 days from the date of delivery of the items purchased hereunder. Amounts not timely paid shall bear interest at the maximum rate permitted by law for each month or portion thereof that Buyer is late in making payment. Any claims by Buyer for omissions or shortages in a shipment shall be waived unless Seller receives notice thereof within 30 days after Buyer's receipt of the shipment.

3. Delivery: Unless otherwise provided on the face hereof, delivery shall be made F.O.B. Seller's plant. Regardless of the method of delivery, however, risk of loss shall pass to Buyer upon Seller's delivery to a carrier. Any delivery dates shown are approximate only and Seller shall have no liability for any delays in delivery.

4. Warranty: Seller warrants that the items sold hereunder shall be free from defects in material or workmanship for a period of 18 months from date of shipment from Parker Hannifin Corporation. THIS WARRANTY COMPRISES THE SOLE AND ENTIRE WARRANTY PERTAINING TO ITEMS PROVIDED HEREUNDER. SELLER MAKES NO OTHER WARRANTY, GUARANTEE, OR REPRESENTATION OF ANY KIND WHATSOEVER. ALL OTHER WARRANTIES, INCLUDING BUT NOT LIMITED TO, MERCHANTABILITY AND FITNESS FOR PURPOSE, WHETHER EXPRESS, IMPLIED, OR ARISING BY OPERATION OF LAW, TRADE USAGE, OR COURSE OF DEALING ARE HEREBY DISCLAIMED.

NOTWITHSTANDING THE FOREGOING, THERE ARE NO WARRANTIES WHATSOEVER ON ITEMS BUILT OR ACQUIRED WHOLLY OR PARTIALLY, TO BUYER'S DESIGNS OR SPECIFICATIONS.

5. Limitation of Remedy: SELLER'S LIABILITY ARISING FROM OR IN ANY WAY CONNECTED WITH THE ITEMS SOLD OR THIS CONTRACT SHALL BE LIMITED EXCLUSIVELY TO REPAIR OR REPLACEMENT OF THE ITEMS SOLD OR REFUND OF THE PURCHASE PRICE PAID BY BUYER, AT SELLER'S SOLE OPTION. IN NO EVENT SHALL SELLER BE LIABLE FOR ANY INCIDENTAL, CONSEQUENTIAL OR SPECIAL DAMAGES OF ANY KIND OR NATURE WHATSOEVER, INCLUDING BUT NOT LIMITED TO LOST PROFITS ARISING FROM OR IN ANY WAY CONNECTED WITH THIS AGREEMENT OR ITEMS SOLD HEREUNDER, WHETHER ALLEGED TO ARISE FROM BREACH OF CONTRACT, EXPRESS OR IMPLIED WARRANTY, OR IN TORT, INCLUDING WITHOUT LIMITATION, NEGLIGENCE, FAILURE TO WARN OR STRICT LIABILITY.

6. Changes, Reschedules and Cancellations: Buyer may request to modify the designs or specifications for the items sold hereunder as well as the quantities and delivery dates thereof, or may request to cancel all or part of this order, however, no such requested modification or cancellation shall become part of the contract between Buyer and Seller unless accepted by Seller in a written amendment to this Agreement. Acceptance of any such requested modification or cancellation shall be at Seller's discretion, and shall be upon such terms and conditions as Seller may require.

7. Special Tooling: A tooling charge may be imposed for any special tooling, including without limitation, dies, fixtures, molds and patterns, acquired to manufacture items sold pursuant to this contract. Such special tooling shall be and remain Seller's property notwithstanding payment of any charges by Buyer. In no event will Buyer acquire any interest in apparatus belonging to Seller which is utilized in the manufacture of the items sold hereunder, even if such apparatus has been specially converted or adapted for such manufacture and notwithstanding any charges paid by Buyer. Unless otherwise agreed, Seller shall have the right to alter, discard or otherwise dispose of any special tooling or other property in its sole discretion at any time.

8. Buyer's Property: Any designs, tools, patterns, materials, drawings, confidential information or equipment furnished by Buyer, or any other items which become Buyer's property, may be considered obsolete and may be destroyed by Seller after two (2) consecutive years have elapsed without Buyer placing an order for the items which are manufactured using such property. Seller shall not be responsible for any loss or damage to such property while it is in Seller's possession or control.

9. Taxes: Unless otherwise indicated on the face hereof, all prices and charges are exclusive of excise, sales, use, property, occupational or like taxes which may be imposed by any taxing authority upon the manufacture, sale or delivery of the items sold hereunder. If any such taxes must be paid by Seller or if Seller is liable for the collection of such tax, the amount thereof shall be in addition to the amounts for the items sold. Buyer agrees to pay all such taxes or to reimburse Seller therefore upon receipt of its invoice. If Buyer claims exemption from any sales, use or other tax imposed by any taxing authority, Buyer shall save Seller harmless from and against any such tax, together with any interest or penalties thereon which may be assessed if the items are held to be taxable.

10. Indemnity for Infringement of Intellectual Property Rights: Seller shall have no liability for infringement of any patents, trademarks, copyrights, trade dress, trade secrets or similar rights except as provided in this Part 10. Seller will defend and indemnify Buyer against allegations of infringement of U.S. patents, U.S. trademarks, copyrights, trade dress and trade secrets (hereinafter "Intellectual Property Rights"). Seller will defend at its expense and will pay the cost of any settlement or damages awarded in an action brought against Buyer based on an allegation that an item sold pursuant to this contract infringes the Intellectual Property Rights of a third party. Seller's obligation to defend and indemnify Buyer is contingent on Buyer notifying Seller within ten (10) days after Buyer becomes aware of such allegations of infringement, and Seller having sole control over the defense of any allegations or actions including all negotiations for settlement or compromise. If an item sold hereunder is subject to a claim that it infringes the Intellectual Property Rights of a third party, Seller may, at its sole expense and option, procure for Buyer the right to continue using said item, replace or modify said item so as to make it noninfringing, or offer to accept return of said item and return the purchase price less a reasonable allowance for depreciation. Notwithstanding the foregoing, Seller shall have no liability for claims of infringement based on information provided by Buyer, or directed to items delivered hereunder for which the designs are specified in whole or part by Buyer, or infringements resulting from the modification, combination or use in a system of any item sold hereunder. The foregoing provisions of this Part 10 shall constitute Seller's sole and exclusive liability and Buyer's sole and exclusive remedy for infringement of Intellectual Property Rights.

If a claim is based on information provided by Buyer or if the design for an item delivered hereunder is specified in whole or in part by Buyer, Buyer shall defend and indemnify Seller for all costs, expenses or judgments resulting from any claim that such item infringes any patent, trademark, copyright, trade dress, trade secret or any similar right.

11. Force Majeure: Seller does not assume the risk of and shall not be liable for delay or failure to perform any of Seller's obligations by reason of circumstances beyond the reasonable control of Seller (hereinafter "Events of Force Majeure"). Events of Force Majeure shall include without limitation, accidents, acts of God, strikes or labor disputes, acts, laws, rules or regulations of any government or government agency, fires, floods, delays or failures in delivery of carriers or suppliers, shortages of materials and any other cause beyond Seller's control.

12. Entire Agreement/Governing Law: The terms and conditions set forth herein, together with any amendments, modifications and any different terms or conditions expressly accepted by Seller in writing, shall constitute the entire Agreement concerning the items sold, and there are no oral or other representations or agreements which pertain thereto. This Agreement shall be governed in all respects by the law of the State of Ohio. No actions arising out of the sale of the items sold hereunder or this Agreement may be brought by either party more than two (2) years after the cause of action accrues.

Cylinder Division Manufacturing Locations

REGIONAL PLANTS

California

221 Helicopter Circle
Corona, CA 92880
Tel.: (909) 280-3800
Fax: (909) 280-3808
Fax: (800) 869-9886

Connecticut

80 Shaker Road
Enfield, CT 06082
Tel.: (860) 749-2215
Fax: (800) 323-0105

Georgia

1300 Six Flags Road
Lithia Springs, GA 30122
Tel.: (770) 819-3400
Fax: (800) 437-3498

Indiana

715 South Iroquois Street
Goodland, IN 47948
Tel.: (219) 297-3182
Fax: (800) 328-8120

Michigan

900 Plymouth Road
Plymouth, MI 48170
Tel.: (734) 455-1700
Fax: (734) 455-1007

Ohio

1000 Home Avenue
Akron, OH 44310
Tel.: (330) 253-4500
Fax: (330) 253-4883

Oregon

13908 N. Lombard
Portland, OR 97203
Tel.: (503) 285-0884
Fax: (800) 323-0195

CANADA

1000 6th Street East
Owen Sound, Ontario
Canada N4K 5P1
Tel.: (519) 376-2691
Fax: (519) 371-2664

530 Kipling Avenue
Toronto, Ontario
Canada M8Z 5E6
Tel.: (416) 255-4567
Fax: (416) 251-6890

2001 Rue de L'Aviation
Dorval, Quebec
Canada H9P 2X6
Tel.: (514) 684-3000
Fax: (514) 684-4191



Parker Hannifin Corporation
Cylinder Division
500 South Wolf Road
Des Plaines, IL 60016 USA
Tel: (847) 298-2400
Fax: (800) 892-1008
Email: Cylmktg@parker.com
Web Site: www.parker.com/cylinder

Parker Hannifin Corporation
Cylinder Division
1000 6th Street East
Owen Sound, Ontario
Canada N4K 5P1
Tel: (519) 376-2691
Fax: (519) 371-2664