

**General Description**

Series PCM pressure compensated flow control valves are designed to regulate flow at a selected rate, within 5%, regardless of fluctuations in inlet and outlet pressure.

**Operation**

Series PCM valves can be adjusted for required flows after being installed.

**Features**

- Available with reverse flow check.
- The exclusive “Colorflow” color-band reference scale on the valve stem is a great convenience and time-saver in setting the valve originally and in returning it to any previous setting.
- A simple set screw locks the valve on any desired setting.
- A tamperproof option (T) feature is also available to prevent accidental or intentional adjustment of flow setting.

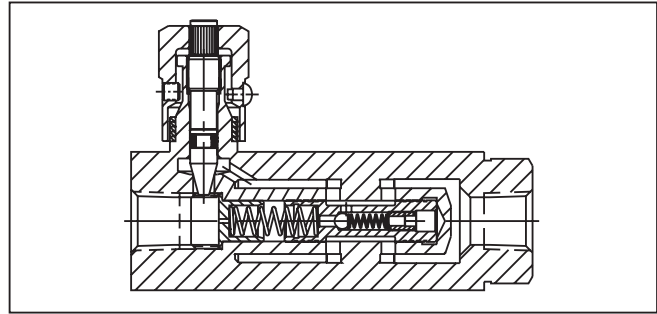
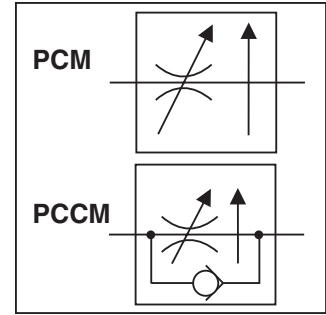

**Specifications**

	<b>PC*M400S</b> <b>PC*M620S</b>	<b>PC*M600S</b> <b>PC*M820S</b>	<b>PC*M800S</b> <b>PC*M1020S</b>	<b>PC*M1200S</b> <b>PC*M1220S</b>	<b>PC*M1600S</b> <b>PC*M1620S</b>	<b>PC*M2000S</b>
<b>Maximum Operating Pressure</b>	207 Bar (3000 PSI)					
<b>Minimum Pressure to Compensate</b>	6.9 Bar (100 PSI)	6.9 Bar (100 PSI)	6.9 Bar (100 PSI)	10.4 Bar (150 PSI)	10.4 Bar (150 PSI)	10.4 Bar (150 PSI)
<b>Temperature Range of Seal Compound</b>	-40°C to +121°C (-40°F to +250°F) Nitrile (standard) -26°C to +205°C (-15°F to +400°F) Fluorocarbon					
<b>Mounting</b>	Inline					
<b>Maximum Flow</b>	11 LPM (3 GPM)	23 LPM (6 GPM)	57 LPM (15 GPM)	95 LPM (25 GPM)	189 LPM (50 GPM)	303 LPM (80 GPM)
<b>Minimum Flow</b>	1 LPM (0.3 GPM)	2 LPM (0.6 GPM)	6 LPM (1.5 GPM)	10 LPM (2.5 GPM)	19 LPM (5.0 GPM)	30 LPM (8 GPM)
<b>Reverse Flow, Maximum thru Check</b>	19 LPM (5 GPM)	30 LPM (8 GPM)	76 LPM (20 GPM)	132 LPM (35 GPM)	227 LPM (60 GPM)	378 LPM (100 GPM)
<b>Pressure Drop, ΔP at Maximum Reverse Flow thru Check</b>	3 Bar (40 PSI)	3 Bar (40 PSI)	PC*M800S: 8 Bar (116 PSI) PC*M1020S: 3 Bar (40 PSI)	PC*M1200S: 8 Bar (116 PSI) PC*M1220S: 3 Bar (40 PSI)	10 Bar (140 PSI)	11 Bar (155 PSI)
<b>Port Size (in.)</b>	PC*M400S: 1/4 NPTF PC*M620S: 9/16-18 UNF (SAE 6)	PC*M600S: 3/8 NPTF PC*M820S: 3/4-16 UNF (SAE 8)	PC*M800S: 1/2 NPTF PC*M1020S: 7/8-14 UNF (SAE 10)	PC*M1200S: 3/4 NPTF PC*M1220S: 1-1/16-12 UNF (SAE 12)	PC*M1600S: 1 NPTF PC*M1620: 1-5/16-12 UNF (SAE 16)	PC*M2000S: 1 1/4" NPTF

\*For optional reverse-flow check, insert “C” in model number at asterisk (\*).

**Ordering Information**

<div style="border: 1px solid black; width: 30px; height: 30px; margin: 0 auto;"></div> <p>Options</p>	<div style="border: 1px solid black; width: 30px; height: 30px; margin: 0 auto; text-align: center; font-weight: bold;">PC</div> <p>Pressure Compensated Flow Control</p>	<div style="border: 1px solid black; width: 30px; height: 30px; margin: 0 auto;"></div> <p>Reverse Check</p>	<div style="border: 1px solid black; width: 30px; height: 30px; margin: 0 auto; text-align: center; font-weight: bold;">M</div> <p>Adjustable Flow</p>	<div style="border: 1px solid black; width: 30px; height: 30px; margin: 0 auto;"></div> <p>Size</p>	<div style="border: 1px solid black; width: 30px; height: 30px; margin: 0 auto;"></div> <p>Material</p>	<div style="border: 1px solid black; width: 30px; height: 30px; margin: 0 auto;"></div> <p>Adjustable Knob Options</p>	<div style="border: 1px solid black; width: 30px; height: 30px; margin: 0 auto;"></div> <p>Seals</p>	<div style="border: 1px dashed black; width: 30px; height: 30px; margin: 0 auto;"></div> <p>Design Series NOTE: Not required when ordering.</p>
--	---	--	--	---	---	--	--	---

  

<table border="1" style="width: 100%; border-collapse: collapse;"> <thead> <tr> <th>Code</th> <th>Description</th> </tr> </thead> <tbody> <tr> <td>Omit</td> <td>NPTF/SAE</td> </tr> <tr> <td>★ 9</td> <td>BSPB</td> </tr> </tbody> </table> <p>★ Code 9 can be used with sizes 400, 600, 800, 1200, 1600</p>	Code	Description	Omit	NPTF/SAE	★ 9	BSPB	<table border="1" style="width: 100%; border-collapse: collapse;"> <thead> <tr> <th>Code</th> <th>Description</th> </tr> </thead> <tbody> <tr> <td>Omit</td> <td>Without</td> </tr> <tr> <td>C</td> <td>Check</td> </tr> </tbody> </table>	Code	Description	Omit	Without	C	Check	<table border="1" style="width: 100%; border-collapse: collapse;"> <thead> <tr> <th>Code</th> <th>Size</th> </tr> </thead> <tbody> <tr> <td>400</td> <td>1/4"</td> </tr> <tr> <td>600 *</td> <td>3/8"</td> </tr> <tr> <td>620</td> <td>#6 SAE</td> </tr> <tr> <td>800 *</td> <td>1/2"</td> </tr> <tr> <td>820</td> <td>#8 SAE</td> </tr> <tr> <td>1020</td> <td>#10 SAE</td> </tr> <tr> <td>1200</td> <td>3/4"</td> </tr> <tr> <td>1220</td> <td>#12 SAE</td> </tr> <tr> <td>1600</td> <td>1"</td> </tr> <tr> <td>1620</td> <td>#16 SAE</td> </tr> <tr> <td>2000</td> <td>1 1/4"</td> </tr> </tbody> </table> <p>* Available in Stainless Steel</p>	Code	Size	400	1/4"	600 *	3/8"	620	#6 SAE	800 *	1/2"	820	#8 SAE	1020	#10 SAE	1200	3/4"	1220	#12 SAE	1600	1"	1620	#16 SAE	2000	1 1/4"	<table border="1" style="width: 100%; border-collapse: collapse;"> <thead> <tr> <th>Code</th> <th>Description</th> </tr> </thead> <tbody> <tr> <td>Omit</td> <td>Standard Knob</td> </tr> <tr> <td>T *</td> <td>Tamperproof</td> </tr> <tr> <td>F</td> <td>Finger Screw</td> </tr> </tbody> </table> <p>* Not available above 1200 size.</p>	Code	Description	Omit	Standard Knob	T *	Tamperproof	F	Finger Screw
Code	Description																																														
Omit	NPTF/SAE																																														
★ 9	BSPB																																														
Code	Description																																														
Omit	Without																																														
C	Check																																														
Code	Size																																														
400	1/4"																																														
600 *	3/8"																																														
620	#6 SAE																																														
800 *	1/2"																																														
820	#8 SAE																																														
1020	#10 SAE																																														
1200	3/4"																																														
1220	#12 SAE																																														
1600	1"																																														
1620	#16 SAE																																														
2000	1 1/4"																																														
Code	Description																																														
Omit	Standard Knob																																														
T *	Tamperproof																																														
F	Finger Screw																																														

  

<table border="1" style="width: 100%; border-collapse: collapse;"> <thead> <tr> <th>Code</th> <th>Description</th> </tr> </thead> <tbody> <tr> <td>Omit</td> <td>Nitrile (Standard)</td> </tr> <tr> <td>V</td> <td>Fluorocarbon (Standard on Stainless Steel)</td> </tr> </tbody> </table>	Code	Description	Omit	Nitrile (Standard)	V	Fluorocarbon (Standard on Stainless Steel)	<table border="1" style="width: 100%; border-collapse: collapse;"> <thead> <tr> <th>Code</th> <th>Description</th> </tr> </thead> <tbody> <tr> <td>S</td> <td>Steel</td> </tr> <tr> <td>SS</td> <td>Stainless Steel</td> </tr> </tbody> </table>	Code	Description	S	Steel	SS	Stainless Steel
Code	Description												
Omit	Nitrile (Standard)												
V	Fluorocarbon (Standard on Stainless Steel)												
Code	Description												
S	Steel												
SS	Stainless Steel												

**Performance Curves**

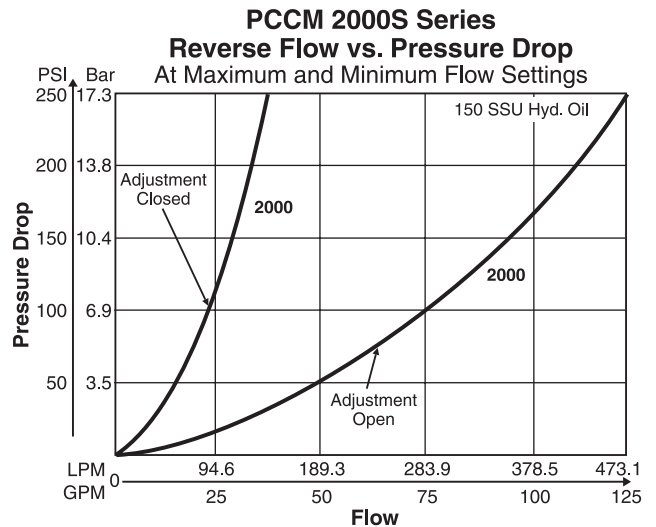
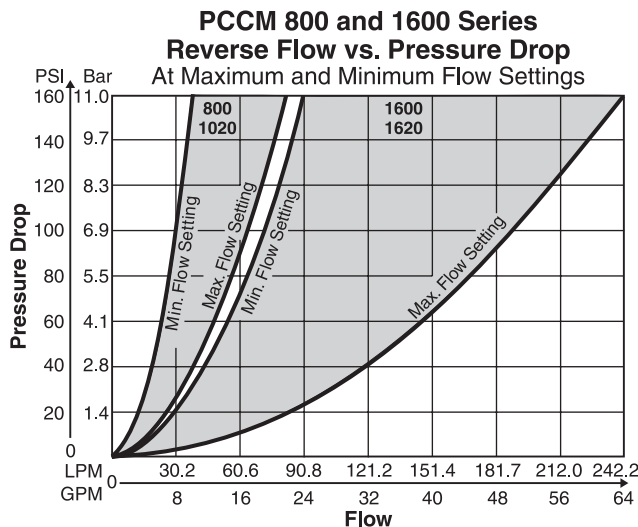
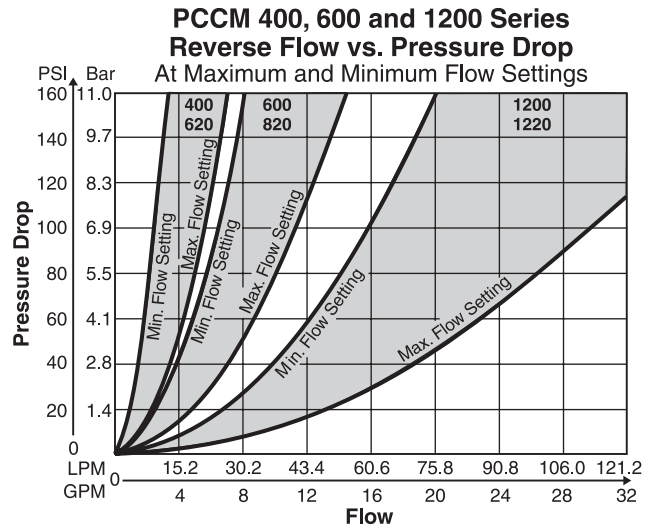
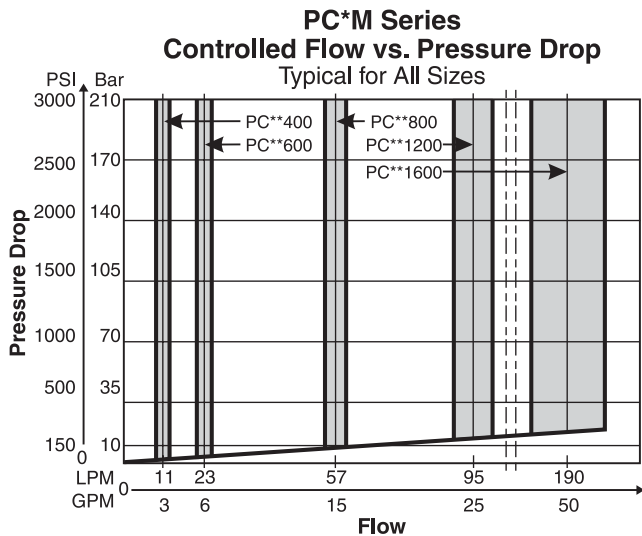

Inch equivalents for millimeter dimensions are shown in (\*\*)

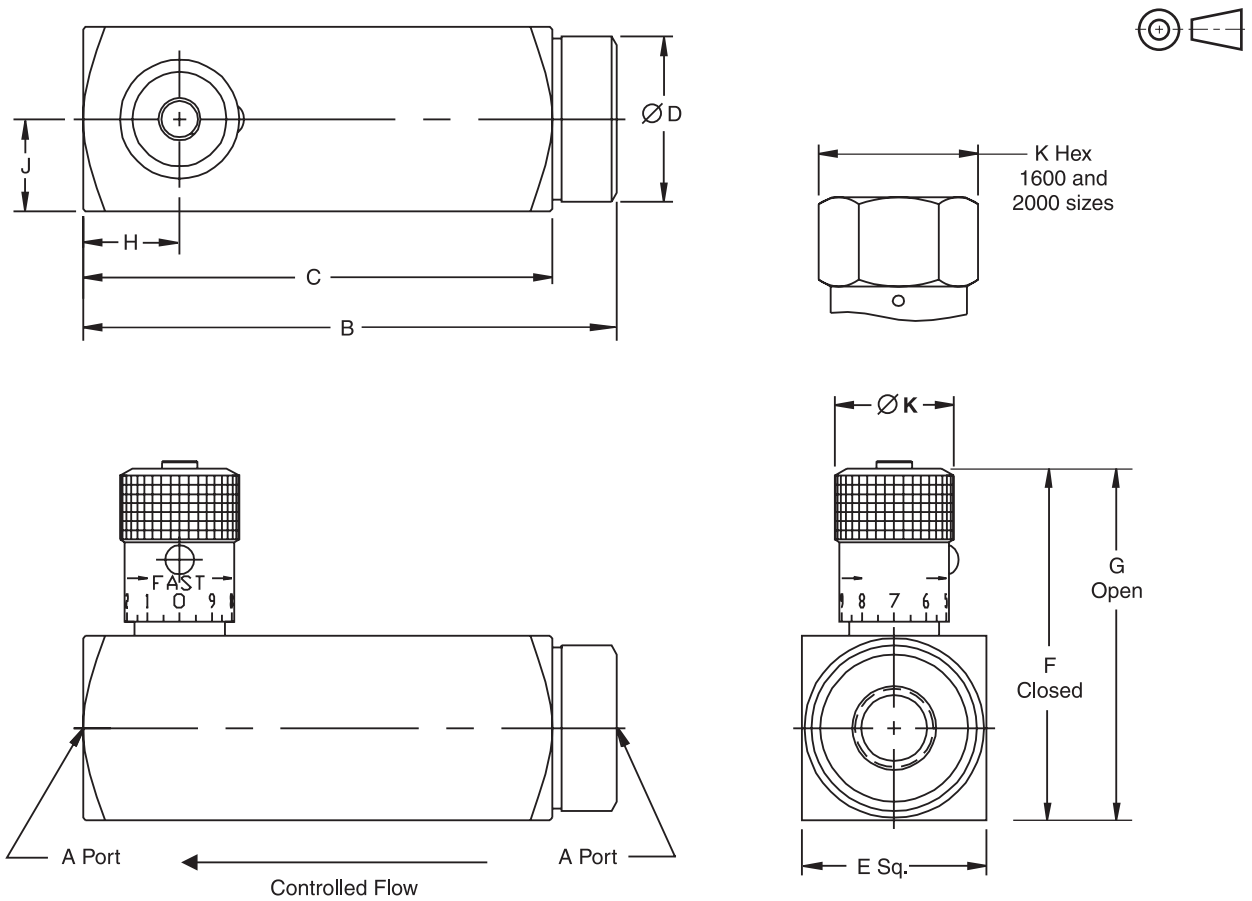

Model Number	Weights kg (lbs.)	A	B	C	D	E	F	G	H	J	K
PC*M400/620	0.8 (1.8)	1/4-18 NPTF 9/16-18 UNF	92.2 (3.63)	81.0 (3.19)	28.7 (1.13)	35.1 (1.38)	64.0 (2.52)	69.3 (2.73)	16.8 (0.66)	17.5 (0.69)	20.6 (0.81)
PC*M600/820	1.0* (2.2)*	3/8-18 NPTF 3/4-16 UNF	105.7 (4.16)	93.0 (3.66)	31.8 (1.25)	38.1 (1.50)	73.7 (2.90)	80.0 (3.15)	17.5 (0.69)	19.1 (0.75)	25.4 (1.00)
PC*M800/1020	1.7 (3.7)	1/2-14 NPTF 7/8-14 UNF	125.5 (4.94)	109.5 (4.31)	38.1 (1.50)	44.5 (1.75)	95.0 (3.74)	102.6 (4.04)	22.4 (0.88)	22.4 (0.88)	30.2 (1.19)
PC*M1200/1220	3.6 (8.0)	3/4-14 NPTF 1 1/16-12 UNF	149.4 (5.88)	130.3 (5.13)	50.8 (2.00)	57.2 (2.25)	115.8 (4.56)	128.5 (5.06)	27.7 (1.09)	28.7 (1.13)	35.1 (1.38)
PC*M1600/1620	6.6 (14.6)	1-11 1/2 NPTF 1 5/16-12 UNF	176.3 (6.94)	155.7 (6.13)	63.5 (2.50)	69.9 (2.75)	158.2 (6.23)	175.3 (6.90)	33.3 (1.31)	35.1 (1.38)	47.8 (1.88)
PC*M2000	11.8 (26.0)	1 1/4-11 1/2 NPTF	212.9 (8.38)	190.5 (7.50)	76.2 (3.00)	88.9 (3.50)	182.1 (7.17)	201.2 (7.92)	41.4 (1.63)	44.5 (1.75)	47.8 (1.88)

\* Weights are for PC\*M600; weights for PC\*M820 are 1.4 kg (3.1lbs.)