



aerospace
climate control
electromechanical
filtration
fluid & gas handling
hydraulics
pneumatics
process control
sealing & shielding



Pneumatic Cylinders

Series P1D-T Tie Rod Line - Ø32 to Ø320 mm
According to ISO 15552

PDE2667TCUK April 2015



ENGINEERING YOUR SUCCESS.



Important

Before attempting any external or internal work on the cylinder or any connected components, make sure the cylinder is vented and disconnect the air supply in order to ensure isolation of the air supply.



Note

All technical data in this catalogue are typical data only.
Air quality is essential for maximum cylinder service life (see ISO 8573).



WARNING

FAILURE OR IMPROPER SELECTION OR IMPROPER USE OF THE PRODUCTS AND/OR SYSTEMS DESCRIBED HEREIN OR RELATED ITEMS CAN CAUSE DEATH, PERSONAL INJURY AND PROPERTY DAMAGE.

This document and other information from Parker Hannifin Corporation, its subsidiaries and authorized distributors provide product and/or system options for further investigation by users having technical expertise. It is important that you analyze all aspects of your application and review the information concerning the product or system in the current product catalog. Due to the variety of operating conditions and applications for these products or systems, the user, through its own analysis and testing, is solely responsible for making the final selection of the products and systems and assuring that all performance, safety and warning requirements of the application are met. The products described herein, including without limitation, product features, specifications, designs, availability and pricing, are subject to change by Parker Hannifin Corporation and its subsidiaries at any time without notice.

SALE CONDITIONS

The items described in this document are available for sale by Parker Hannifin Corporation, its subsidiaries or its authorized distributors. Any sale contract entered into by Parker will be governed by the provisions stated in Parker's standard terms and conditions of sale (copy available upon request).

Contents	page
P1D-T – ISO 15552 Cylinder Range	4
Cylinder forces, double acting variants	6
Main data : P1D-T	6
Cushioning characteristics	7
Guide for selecting tubing	8 - 9
General technical data	10
Operating and environmental data	10
Material specification - Bores Ø32 to Ø125 mm	10
Material specification - Bores Ø160, Ø200 and Ø250 mm	11
Material specification - Bores Ø320 mm	12
Order key code - Basic Cylinder	13
Order key code - Cylinder with Intermediate trunnion	14
Order key code - Extended piston rod	15
Order key code - Piston rod in alternative materials.....	15
Order key code - Through piston rod	16
Order key code - Operation with a dry piston rod.....	16
Order key code - 3 and 4 position cylinders	17
Order key code - Tandem cylinders	17
Standard strokes - Bores Ø32 to Ø125 mm - Standard temperature	18
Dimensions - Bores Ø32 to Ø125 mm - Standard temperature	19
Standard strokes - Bores Ø32 to Ø125 mm - High temperature.....	20
Dimensions - Bores Ø32 to Ø125 mm - Standard temperature	21
Dimensions - 3 and 4 position cylinders	22
Order key code - Bores Ø32 to Ø125 mm	23
Standard strokes - Bores Ø160 to Ø320 mm.....	24
Dimensions - Bores Ø160 to Ø320 mm	25
Order key code - Bores Ø160 to Ø320 mm	26
Rod guidance modules.....	27 - 30
Cylinder mountings	31 - 37
Piston rod mountings	38 - 39
Accessories	40
Sensors	41 - 44
P1D Seal kits Ø32 - Ø125 mm	45
Seal kits Ø160 - Ø250 mm	46
Seal kits - Ø320 mm	47
Order code key - Spare parts	49
Specifying air quality	50
Introduction to ATEX directive	51 - 54

Design variants

The P1D-T range of tie rod cylinders is intended for use in a wide range of applications. Careful design and high quality manufacture throughout ensure long service life and optimum economy.

Mounting dimensions fully in accordance with ISO 15552 (ISO 6431 and CETOP RP52P) greatly simplifies installation and world-wide interchangeability.

For extreme conditions these cylinders for high and low temperatures have materials and sealing systems specially designed for their particular temperature ranges. Piston is made entirely from aluminium, to give optimum function at high or low temperature in combination with seals made from specially tested materials and special grease.

3 and 4 positions cylinders

This type of cylinder function consists of two cylinders installed back to back. Two cylinders with the same stroke give a 3 positions cylinder with a symmetrical centre position, whereas different strokes give a 4 positions cylinder where the two central positions can be calculated from the different stroke lengths. This type of unit is available as factory-fitted P1D tie-rod cylinders in bores Ø32 to 125 mm. Note that otherwise two cylinders can be flange mounted back-to-back with a special mounting.

Tandem version

The P1D is also available as a tandem cylinder, i.e. two cylinders connected in series. This cylinder unit has almost twice the force, which is a great advantage in restricted spaces. Tandem cylinders are available in bores Ø32 to 125 mm.

Alternative piston rod materials

All P1D cylinders can be ordered with the following piston rod materials:

- Steel, hard chromed
- Stainless steel, roller polished (standard)
- Acid-proof steel, roller polished
- Stainless steel, hard chromed

Through piston rod

All P1D cylinders are available with a through rod. Cylinders with a through piston rod can take higher side forces. Thanks to the double support of the piston rod. In addition, this design, with tie rods, makes it easier to install external position sensors.



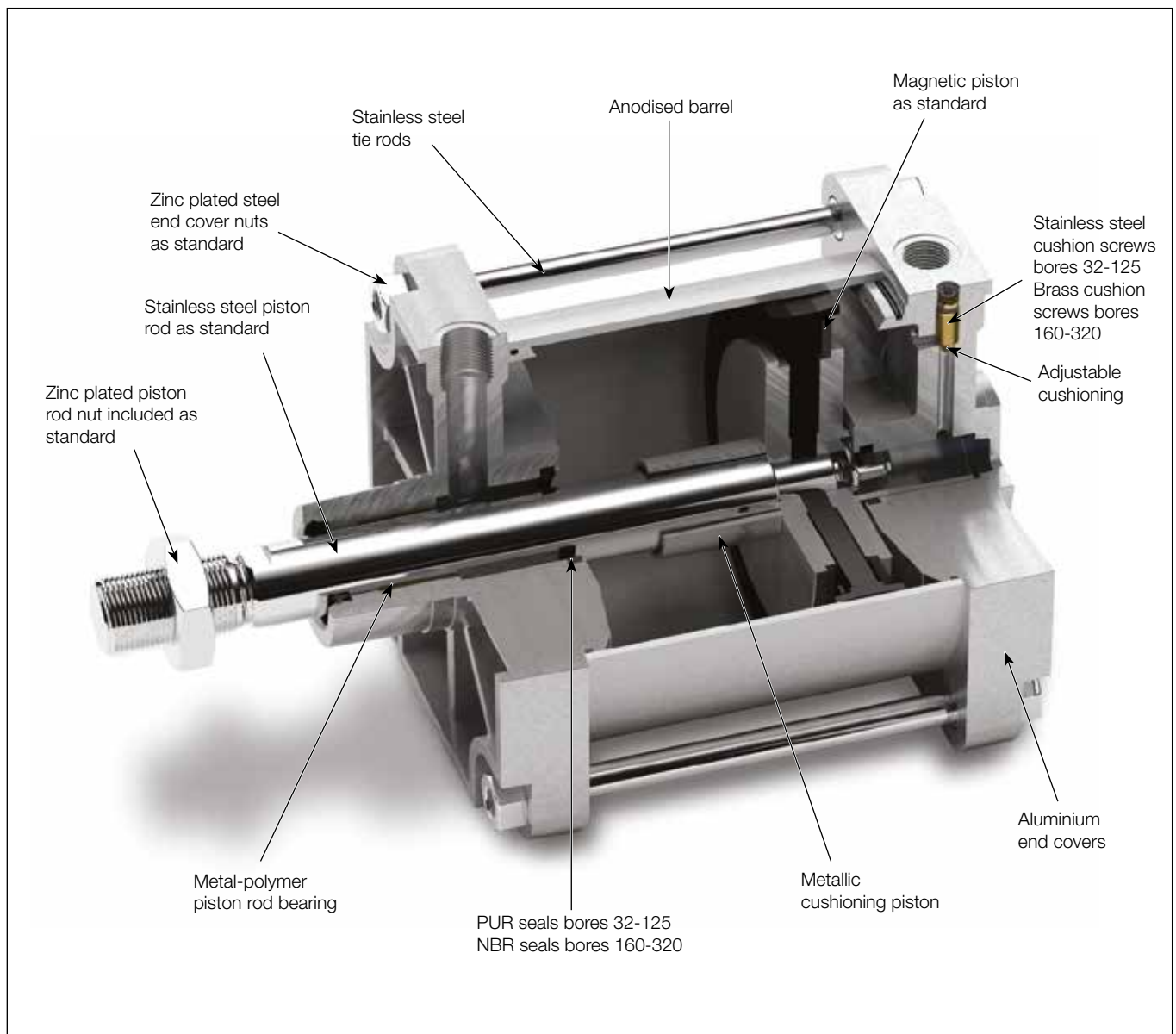

Standard cylinders P1D-T, ISO 15552 bores Ø32 - Ø320 mm

Global product range

The P1D-T range of cylinders is intended for use in a wide range of applications.

Careful design and high quality manufacture throughout ensure long service life and optimum economy.

Mounting dimensions fully in accordance with ISO 15552 (ISO 6431 and CETOP RP52P) greatly simplifies installation and world-wide interchangeability.

Features

- Bore sizes Ø32 - Ø320 mm
- Stroke lengths 5 - 2800mm. (32-125)
- Stroke lengths 10 - 2000mm. (160-320)
- Magnetic piston as standard
- Adjustable cushioning as standard
- Special versions on request
- ATEX version (160-320)

P1D-T Pneumatic ISO Cylinders - Ø32 - Ø320 mm

Cylinder forces, double acting variants

Cyl. bore/ pist. rod mm	Stroke	Piston area cm ²	Max theoretical force in N (bar)									
			1,0	2,0	3,0	4,0	5,0	6,0	7,0	8,0	9,0	10,0
32/12	+	8,0	80	161	241	322	402	483	563	643	724	804
	-	6,9	69	138	207	276	346	415	484	553	622	691
40/16	+	12,6	126	251	377	503	628	754	880	1005	1131	1257
	-	10,6	106	212	318	424	530	636	742	848	954	1060
50/20	+	19,6	196	393	589	785	982	1178	1374	1571	1767	1963
	-	16,5	165	330	495	660	825	990	1155	1319	1484	1649
63/20	+	31,2	312	623	935	1247	1559	1870	2182	2494	2806	3117
	-	28,0	280	561	841	1121	1402	1682	1962	2242	2523	2803
80/25	+	50,3	503	1005	1508	2011	2513	3016	3519	4021	4524	5027
	-	45,4	454	907	1361	1814	2268	2721	3175	3629	4082	4536
100/25	+	78,5	785	1571	2356	3142	3927	4712	5498	6283	7069	7854
	-	73,6	736	1473	2209	2945	3682	4418	5154	5890	6627	7363
125/32	+	122,7	1227	2454	3682	4909	6136	7363	8590	9817	11045	12272
	-	114,7	1147	2294	3440	4587	5734	6881	8027	9174	10321	11468
160/40	+	201,0	2010	4019	6029	8038	10048	12058	14067	16077	18086	20096
	-	188,4	1884	3768	5652	7536	9420	11304	13188	15072	16956	18840
200/40	+	314,2	3142	6283	9425	12566	15708	18850	21991	25133	28274	31416
	-	294,5	2945	5891	8836	11781	14727	17672	20617	23562	26508	29453
250/50	+	490,9	4909	9818	14726	19635	24544	29453	34362	39270	44179	49088
	-	471,3	4713	9425	14138	18850	23563	28275	32988	37700	42413	47125
320/63	+	804,25	8043	16085	24128	32170	40213	48255	56298	64340	72383	80425
	-	773,1	7731	15462	23192	30923	38654	46385	54116	61846	69577	77308

+ = Outward stroke
- = Return stroke

Note!

Select a theoretical force 50-100% larger than the force required

Main data: P1D-T

Cylinder designation	Cylinder		Piston rod		Piston rod thread	Cushioning length mm	Consumption ²⁾ litre	Connection thread
	bore mm	area cm ²	dia. mm	area cm ²				
P1D-T032••XXXX ¹⁾	32	8,0	12	1,1	M10x1,25	17	0,105	G1/8
P1D-T040••XXXX ¹⁾	40	12,6	16	2,0	M12x1,25	19	0,162	G1/4
P1D-T050••XXXX ¹⁾	50	19,6	20	3,1	M16x1,5	20	0,253	G1/4
P1D-T063••XXXX ¹⁾	63	31,2	20	3,1	M16x1,5	23	0,414	G3/8
P1D-T080••XXXX ¹⁾	80	50,3	25	4,9	M20x1,5	23	0,669	G3/8
P1D-T100••XXXX ¹⁾	100	78,5	25	4,9	M20x1,5	27	1,043	G1/2
P1D-T125••XXXX ¹⁾	125	122,7	32	8,0	M27x2	30	1,662	G1/2
P1D-T160••XXXX ¹⁾	160	201,0	40	12,6	M36x2	52	2,815	G3/4
P1D-T200••XXXX ¹⁾	200	314,2	40	19,6	M36x2	52	4,398	G3/4
P1D-T250••XXXX ¹⁾	250	490,9	50	19,6	M42x2	52	6,872	G1
P1D-T320••XXXX ¹⁾	320	804,3	63	31,2	M48x2	50	11,259	G1

Total mass including moving parts

Cylinder designation	Total mass (kg) at 0 mm stroke	Total mass (kg) Supplement per 10 mm stroke
P1D-T032••XXXX ¹⁾	0,55	0,023
P1D-T040••XXXX ¹⁾	0,80	0,033
P1D-T050••XXXX ¹⁾	1,20	0,048
P1D-T063••XXXX ¹⁾	1,73	0,051
P1D-T080••XXXX ¹⁾	2,45	0,075
P1D-T100••XXXX ¹⁾	4,00	0,084
P1D-T125••XXXX ¹⁾	6,87	0,138
P1D-T160••XXXX ¹⁾	10,45	0,205
P1D-T200••XXXX ¹⁾	17,80	0,220
P1D-T250••XXXX ¹⁾	31,00	0,40
P1D-T320••XXXX ¹⁾	60,00	0,60

Mass moving parts only (for cushioning calculation)

Cylinder designation	Mass moving parts (kg) at 0 mm stroke	Supplement per 10 mm stroke
P1D-T032••XXXX ¹⁾	0,13	0,009
P1D-T040••XXXX ¹⁾	0,24	0,016
P1D-T050••XXXX ¹⁾	0,42	0,025
P1D-T063••XXXX ¹⁾	0,50	0,025
P1D-T080••XXXX ¹⁾	0,90	0,039
P1D-T100••XXXX ¹⁾	1,10	0,039
P1D-T125••XXXX ¹⁾	2,34	0,063
P1D-T160••XXXX ¹⁾	x	x
P1D-T200••XXXX ¹⁾	x	x
P1D-T250••XXXX ¹⁾	x	x
P1D-T320••XXXX ¹⁾	x	x

1) XXXX = stroke

2) Free air consumption per 10 mm stroke for a double stroke at 6 bar

Cushioning characteristics

The diagram below is used for dimensioning of cylinders related to the cushioning capacity. The maximum cushioning capacity shown in the diagram assumes the following:

- Low load, i.e. low pressure drop across the piston
- Equilibrium speed
- Correctly adjusted cushioning screw
- 6 bar at cylinder port

The load is the sum of internal and external friction, plus any gravitational forces. At high relative load (pressure drop exceeding 1 bar), we recommend that for any given speed, the mass should be reduced by a factor of 2.5, or for a given mass, the speed should be reduced by a factor of 1.5. This is in relation to the maximum performance given in the diagram

Ø32 - Ø125

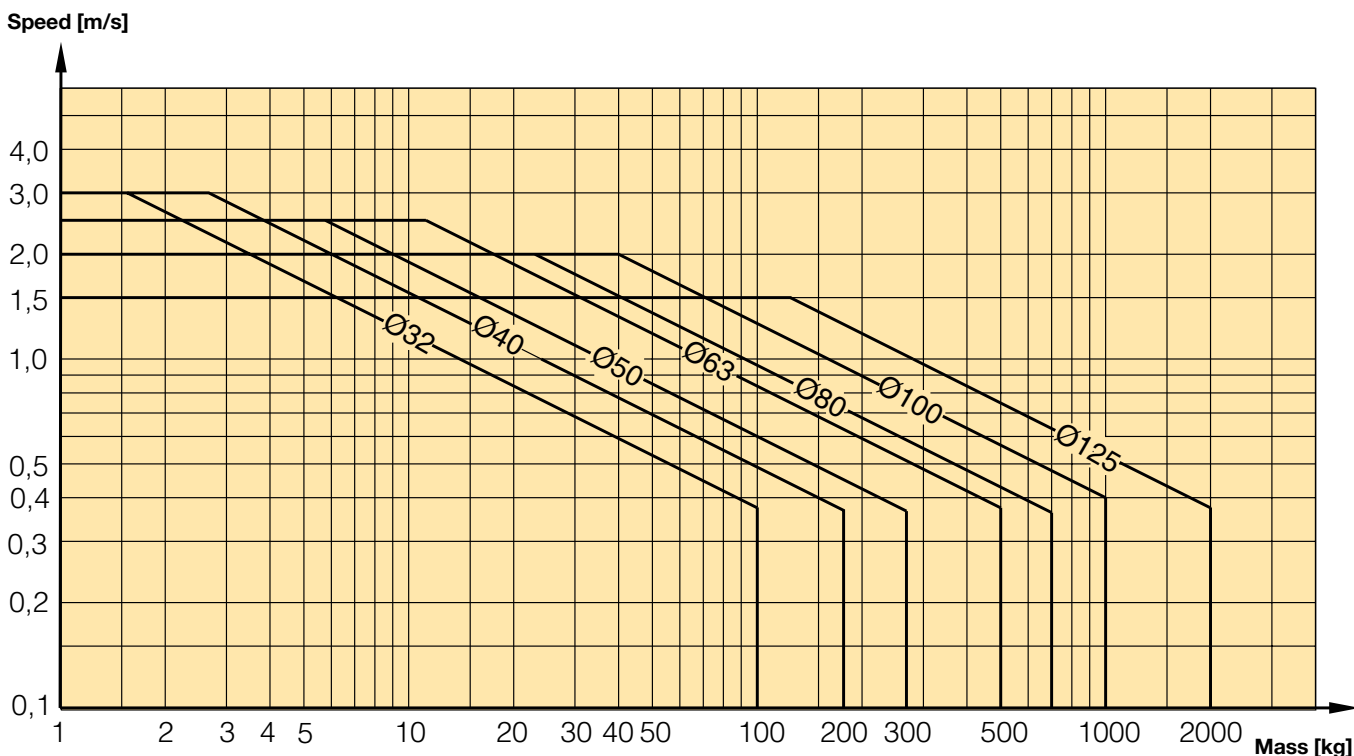

Ø160 - Ø320

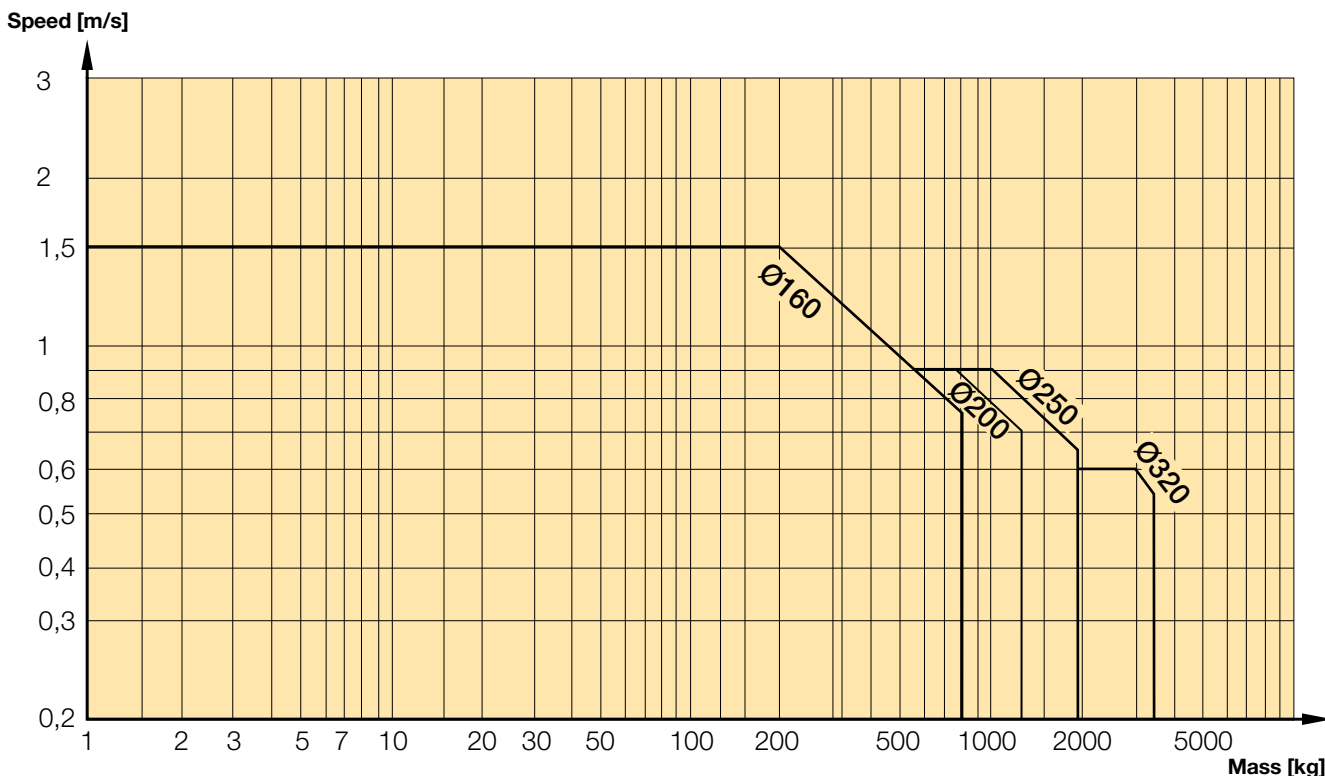

Guide for selecting suitable tubing

The selection of the correct size of tubing is often based on experience, with no great thought to optimizing energy efficiency and cylinder velocity. This is usually acceptable, but making a rough calculation can result in worthwhile economic gains.

The following is the basic principle:

1. The primary line to the working valve could be over sized (this does not cause any extra air consumption and consequently does not create any extra costs in operation).
2. The tubes between the valve and the cylinder should, however, be optimized according to the principle that an insufficient bore throttles the flow and thus limits the cylinder speed, while an oversized pipe creates a dead volume which increases the air consumption and filling time.

The chart below is intended to help when selecting the correct size of tube to use between the valve and the cylinder.

The following prerequisites apply:

The *cylinder load should be about 50% of the theoretical force (= normal load)*. A lower load gives a higher velocity and vice versa. The tube size is selected as a function of the *cylinder bore*, the desired *cylinder velocity* and the *tube length* between the valve and the cylinder.

If you want to use the capacity of the valve to its maximum, and obtain maximum speed, the tubing should be chosen so that they at least correspond with the equivalent restriction diameter (see description below), so that the tubing does not restrict the total flow. This means that a short tubing must have at least the equivalent restriction diameter. If the tubing is longer, choose it from the table below. Straight fittings should be chosen for highest flow rates. (Elbow and banjo fittings cause restriction.)

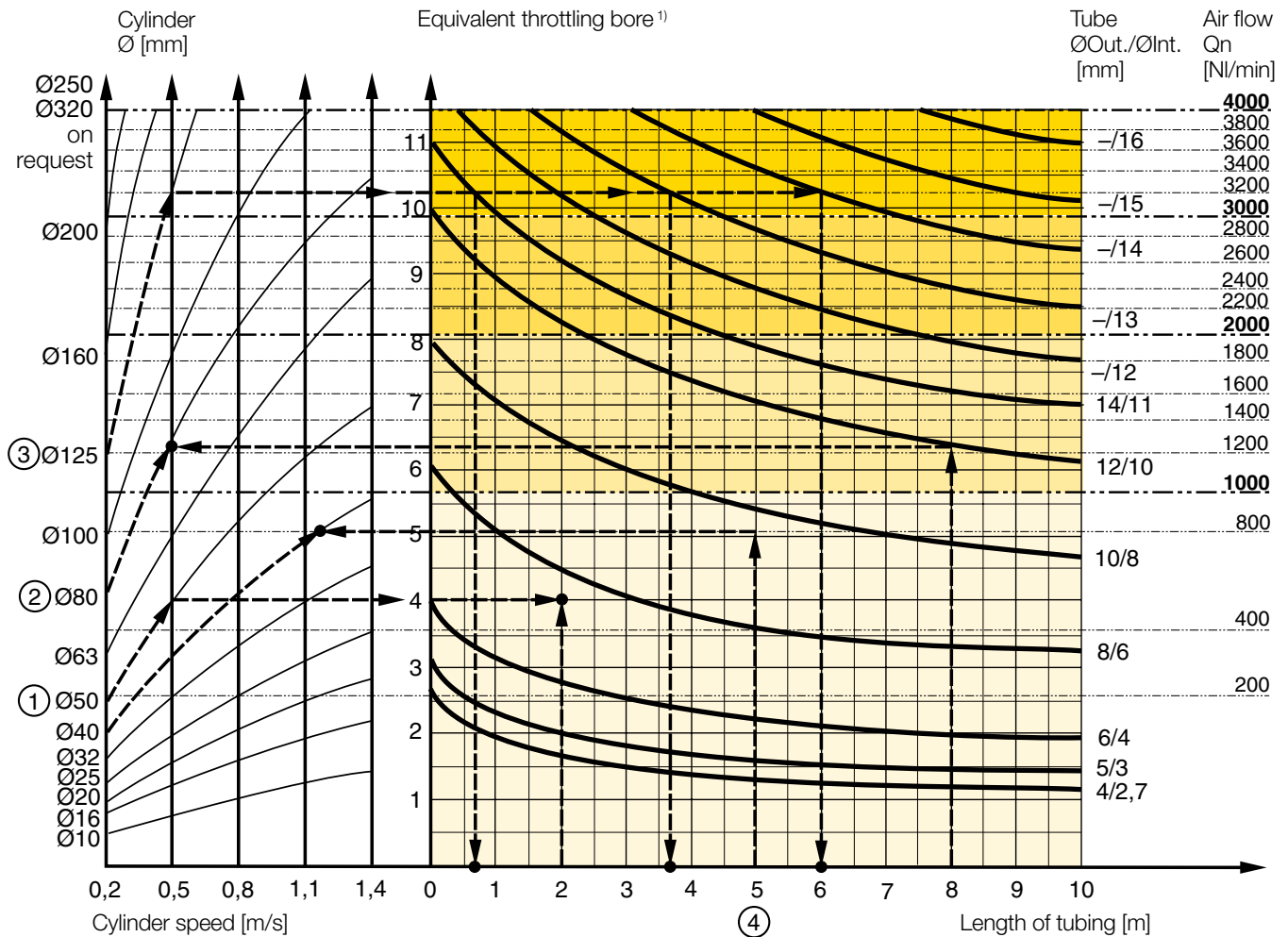

- 1) The "equivalent throttling bore" is a long throttle (for example a tube) or a series of throttles (for example, through a valve) converted to a short throttle which gives a corresponding flow rate. This should not be confused with the "orifice" which is sometimes specified for valves. The value for the orifice does not normally take account of the fact that the valve contains a number of throttles.
- 2) Qn is a measure of the valve flow capacity, with flow measured in litre per minute (l/min) at 6 bar(e) supply pressure and 1 bar pressure drop across the valve.

P1D-T Pneumatic ISO Cylinders - Ø32 - Ø320 mm

Example ① : Which tube diameter should be used?

A 50 mm bore cylinder is to be operated at 0.5 m/s. The tube length between the valve and cylinder is 2 m. In the diagram we follow the line from 50 mm bore to 0.5 m/s and get an "equivalent throttling bore" of approximately 4 mm. We continue out to the right in the chart and intersect the line for a 2 m tube between the curves for 4 mm (6/4 tube) and 6 mm(8/6 tube). This means that a 6/4 tube throttles the velocity somewhat, while an 8/6 tube is a little too large. We select the 8/6 tube to obtain full cylinder velocity.

Example ② : What cylinder velocity will be obtained?

A 80 mm bore cylinder will be used, connected by 8 m 12/10 tube to a valve with Qn 1200 NI/min. What cylinder velocity will we get? We refer to the diagram and follow the line from 8 mm tube length up to the curve for 12/10 tube. From there, we go horizontally to the curve for the Ø80 cylinder. We find that the velocity will be about 0.5 m/s.

Example ③ : What is the minimum inner diameter and maximum length of tube?

For an application a 125 mm bore cylinder will be used. Maximum velocity of piston rod is 0.5 m/s. The cylinder will be controlled by a valve with Qn 3200 NI/min. What diameter of tube can be used and what is maximum length of tube.

We refer to the diagram. We start at the left side of the diagram cylinder Ø125. We follow the line until the intersection with the velocity line of 0.5 m/s. From here we draw a horizontal line in the diagram. This line shows us we need an equivalent throttling bore of approximately 10 mm. Following this line horizontally we cross a few intersections. These intersections shows us the minimum inner diameter (rightside diagram) in combination with the maximum length of tube (bottomside diagram).

For example:

Intersection one: When a tube (14/11) will be used, the maximum length of tube is 0.7 meter.

Intersection two: When a tube (—/13) will be used, the maximum length of tube is 3.7 meter.

Intersection three: When a tube (—/14) will be used, the maximum length of tube is 6 meter.

Example ④ : Determining tube size and cylinder velocity with a particular cylinder and valve?

For an application using a 40 mm bore cylinder with a valve with Qn=800 NI/min. The distance between the cylinder and valve has been set to 5 m.

Tube dimension: What tube bore should be selected to obtain the maximum cylinder velocity? Start at pipe length 5 m, follow the line up to the intersection with 800 NI/min. Select the next largest tube diameter, in this case Ø10/8 mm.

Cylinder velocity: What maximum cylinder velocity will be obtained? Follow the line for 800 NI/min to the left until it intersects with the line for the Ø40 mm cylinder. In this example, the speed is just above 1.1 m/s.

Valve series with respective flows in NI/minute

Valve series	Qn in NI/Min
Interface PS1	120
Moduflex Size 1 - Double 4/2 single solenoid	165
Adex A05	173
Isys Micro - Single 5/3 APB	228
Moduflex Size 1 - Single or Double 3/2	235
Isys Micro - Double 3/2	276
Isys Micro - Single 5/2	282
Moduflex Size 1 - Single 4/2	310
ISOMAX DX02	378
ISYS ISO HB	390
Moduflex Size 2 - Single or Double 3/2	440
PVL-B stackable inline valve	540
Adex A12	560
ISOMAX DX01	588
Viking Xtrem P2LAX - G1/8"	660
Moduflex Size 2 - Single 4/2	800
ISYS ISO HA	918
ISOMAX DX1 & DX Rail	1032
PVL-C stackable inline valve	1100
ISYS ISO H1	1248
Viking Xtrem P2LBX - G1/4"	1290
ISOMAX DX2 & DX Rail	2298
Viking Xtrem P2LCX - G3/8"	2460
ISYS ISO H2	2520
Viking Xtrem P2LDX - G1/2"	2658
ISOMAX DX3 & DX Rail	3840
ISYS ISO H3	5022

General technical data

Product type	Standard cylinder according to ISO 15552
Bore size	32 - 125 mm
Stroke length	10-2800 mm
Versions	Double acting
Cushioning	Adjustable air cushioning
Position sensing	Proximity sensor in temperature range -25°C to +80°C
Installation	P1D cylinder and piston rod mountings
Mounting position	Any

Operating and environmental data

Operating medium	For best possible service life and trouble-free operation dry, filtered compressed air to ISO 8573-1:2010 quality class 3.4.3 should be used. This specifies a dew point of +3°C for indoor operation (a lower dew point should be selected for minus temperature operation and we recommend the use of an inline dryer) and is in line with the air quality from most standard compressors with a standard filter.		
Operating pressure	0,5 bar to 10 bar	Hydraulic version : 2 bar to 10 bar	
Ambient temperature	High temp version : -10°C to +150°C Low temp version : -40°C to +80°C	Hydraulic version : Metal scraper version : -30°C to +80°C	Standard temp version : -20°C to +80°C
Pre-lubricated	Further lubrication is normally not necessary. If additional lubrication is introduced it must be continued.		
Oil used for hydraulic version	Hydraulic oil type HLP (DIN 51524, ISO 11158). Viscosity by 40°C: 32 mm ² /s (cst). Example: Shell Tellus 32 or equal.		
Corrosion resistance	High resistance to corrosion and chemicals. Materials and surface treatment have been selected for industrial applications where solvents and detergents are frequently used.		

Material specification - Bores Ø32 to 125 mm

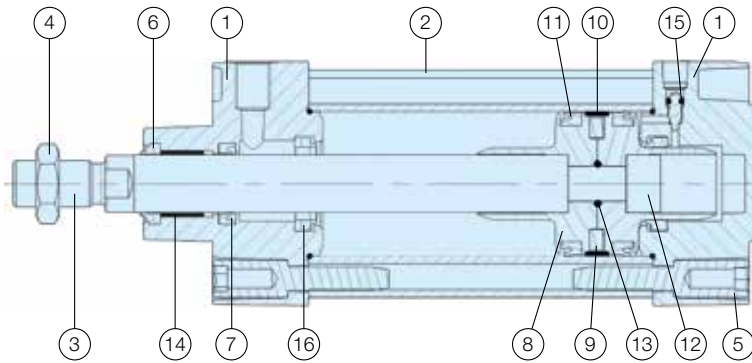

Pos	Part	Specification	
1	End covers	Anodised aluminium	
2	Cylinder barrel	Anodised aluminium	
3	Piston rod	Standard Optional	Stainless steel, DIN X 10 CrNiS 18 9 Hard chromium plated Fe 490-2 FN Acid-proof steel Chrome plated stainless steel
4	Piston rod nut	Standard Optional Optional	Zinc plated steel Stainless steel Acid-proof steel
5	End cover screws	Standard Optional	Zinc plated steel Stainless steel
6	Scraper ring	High temperature Standard & low temperature, hydraulic Metal scraper standard temperature	FPM (Viton) PUR (Polyurethane) Stainless steel / Brass / NBR
7	Piston rod seal	High temperature Standard & low temperature Hydraulic	FPM (Viton) PUR (Polyurethane) NBR(Nitrile)
8	Piston		Aluminium
9	Magnet		Plastic coated magnetic material (Low temperature version only)
10	Piston bearing		PTFE
11	Piston seals	High temperature Standard & low temperature Hydraulic	FPM (Viton) PUR (Polyurethane) NBR(Nitrile)
12	Piston bolt		Zinc plated steel
13	O-rings		Nitrile rubber
14	Piston rod bearing		Multilayer PTFE/steel
15	Cushioning screws		Stainless steel, DIN X 10 CrNiS 18 n9
16	Cushioning seals	High temperature Standard & low temperature	FPM (Viton) PUR (Polyurethane)
	Note on materials		RoHS compliant

P1D-T Pneumatic ISO Cylinders - Ø32 - Ø320 mm**General technical data**

Product type	Standard cylinder according to ISO 15552
Bore size	160 - 320 mm
Stroke length	10-2000 mm
Versions	Double acting
Cushioning	Adjustable air cushioning
Position sensing	Proximity sensor in temperature range -25°C to +80°C
Installation	P1D cylinder and piston rod mountings
Mounting position	Any

Operating and environmental data

Operating medium	For best possible service life and trouble-free operation dry, filtered compressed air to ISO 8573-1:2010 quality class 3.4.3 should be used. This specifies a dew point of +3°C for indoor operation (a lower dew point should be selected for outdoor operation) and is in line with the air quality from most standard compressors with a standard filter.
Operating pressure	1,0 bar to 10 bar
Ambient temperature	
Standard version	-20°C to +80°C
High temp.version	-10°C to +150°C
Pre-lubricated	Further lubrication is normally not necessary. If additional lubrication is introduced it must be continued.
Corrosion resistance	High resistance to corrosion and chemicals. Materials and surface treatment have been selected for industrial applications where solvents and detergents are frequently used.

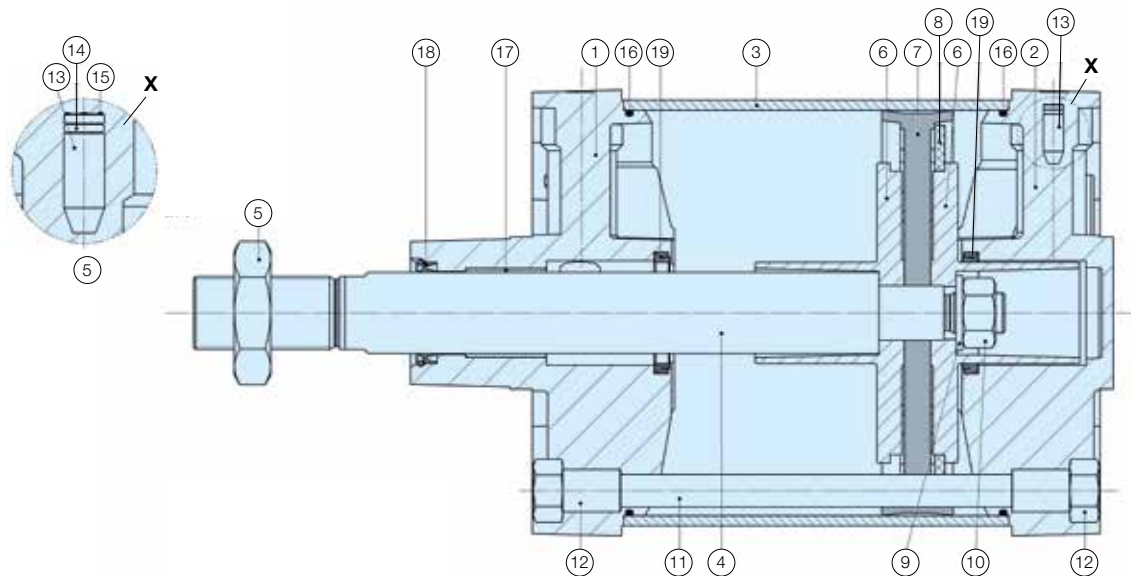
Material specification - Bores Ø160, Ø200 and Ø250 mm

Pos	Part	Specification	
1	Front cover	Aluminium	
2	Rear cover	Aluminium	
3	Cylinder barrel	Anodised aluminium	
4	Piston rod	Standard	Stainless steel 1.4104 (X12CrMoS17)
		Option	Chrome plated steel 1.5217 (20MnV6)
5	Piston rod nut	Zinc plated steel	
6	Cushioning piston	Aluminium	
7	Piston seal	Standard	NBR
		Option	FKM
8	Magnet	Magnet foil	
9	Washer	Zinc plated steel	
10	Piston nut	Zinc plated steel	
11	Tie rod	High alloyed steel 1.4104 (X12CrMoS17)	
12	Tie rod nut	Zinc plated steel	
13	Cushioning screw	Brass	
14	Cushioning O ring	Standard	NBR
		Option	FKM
15	Retaining clip	Spring steel	
16	O ring	Standard	NBR
		Option	FKM
17	Rod bearing	Metal-polymer material	
18	Rod seal	Standard	NBR
		Option	FKM
19	Cushion seal	Standard	NBR
		Option	FKM

Material specification - Bore Ø320 mm

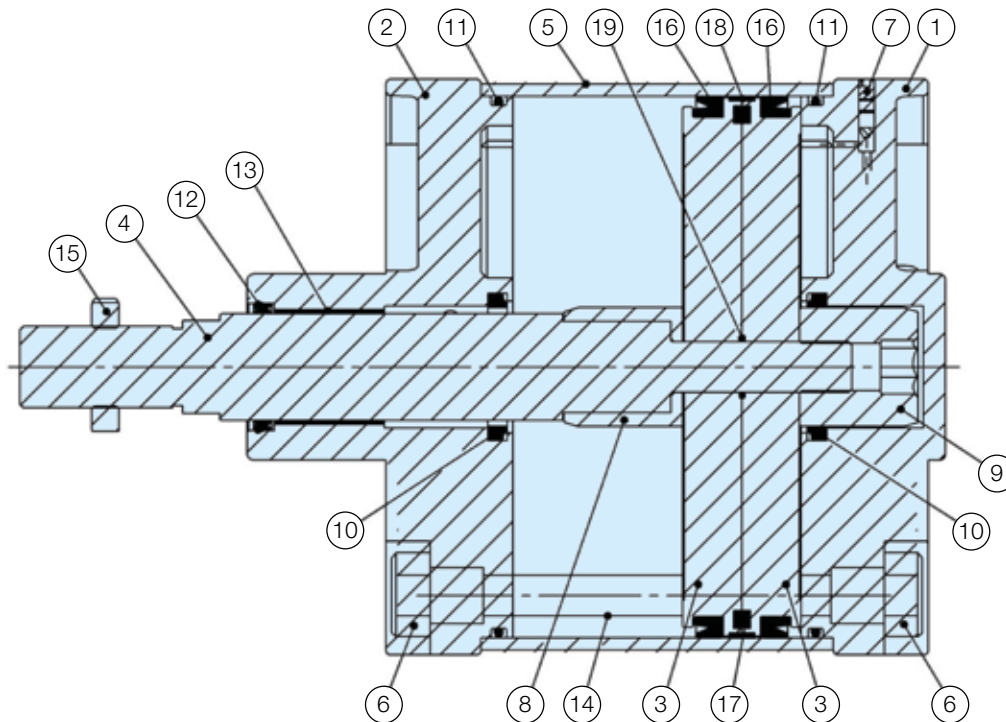

Pos	Part		Specification
1	Rear cover		Aluminium
2	Front cover		Aluminium
3	Piston		Aluminium
4	Piston rod	Standard	Stainless steel 1.4021 (X20Cr13)
		Option	Chrome plated steel 1.5217 (20MnV6)
5	Cylinder barrel		Anodised aluminium
6	Tie rod nut	Standard	Zinc plated steel
		Option	Stainless steel 1.4301 (X5CrNi18-10)
7	Cushioning screw		Brass + Stainless steel
8	Cushioning tube		Anodised aluminium
9	Cushioning female thread		Anodised aluminium
10	Cushioning seal	Standard	PU
		Option	FKM
11	O ring	Standard	NBR
		Option	FKM
12	Rod seal	Standard	PU + HYTREL
		Option	FKM + PTFE + Bronze
13	Rod bearing		Metal + Polymer composite
14	Tie rod	Standard	Stainless steel, 1.4301 (X5CrNi18-10)
15	Piston rod nut	Standard	Zinc plated steel
		Option	Stainless steel 1.4301 (X5CrNi18-10)
16	Piston seals	Standard	PU
		Option	FKM
17	Magnet		Plasto - Ferrite
18	Piston bearing		PTFE + Bronze
19	Piston O-ring	Standard	NBR
		Option	FKM

P1D-T Pneumatic ISO Cylinders - Ø32 - Ø125 mm

The simple and complete order code key

The P1D order key is based on the same principles as its predecessors, the P1C and P1E. This makes it easy to identify and order all common cylinder versions. The change-over from our previous cylinder ranges to the equivalent P1D cylinders is logical and simple. As far as possible, the same symbols as for P1C and P1E have been retained for the same functions. Most of the common cylinder types in the P1D family have a 15-digit order number.

Many of our complete working units (with factory-fitted cylinder mountings, sensors etc.) are defined by a 20-digit order number. There is only one single order key for P1D, which thus contains the 15-digit order numbers for the most common cylinder types and 20-digit order numbers for cylinders with more functions. Remember that there are always 15 or 20 positions in the order number – never any figure in between.

1	2	3	4	5	6	7	8	9	10	11	12	13	14	15
P	1	D	-	T	0	3	2	M	S	-	0	1	0	0

Cylinder version

T	Tie rod
----------	---------

Stroke (mm)
e.g. **0100** = 100 mm

Optional stroke lengths up to 2800 mm. Standard strokes see table.

Cylinder bore mm

032
040
050
063
080
100
125
160
200
250
320

End cover screws						Function
Standard			Stainless steel ²²⁾			
Std scraper	HDPE scraper ²³⁾	FPM scraper ²⁴⁾	Std scraper	HDPE scraper ²³⁾	FPM scraper ²⁴⁾	
M	D	V	A	H	W	Double-acting
F	E	B	G	Y	Z	Double-acting through rod

Note: see the model codes for possible combination of options with bore sizes.

Piston rod material				Seals
Stainless steel	Chromium-plated steel	Acid-proof steel	Chrom.-pl. stainless steel	
S	C	M	R	Standard -20 °C to +80 °C.

22) If stainless steel end cover screws are selected, the piston rod nuts are also supplied in stainless steel.

23) For dry rod operation.

24) FPM scraper should be chosen for higher chemical resistance on standard temperature versions only.

Examples Standard, double acting cylinder

Standard cylinder with standard scraper ring (PUR), standard piston rod material (stainless steel) and standard temperature range.

P1D-T032MS-0160

P1D-T100MS-0400

P1D-T Pneumatic ISO Cylinders - Ø32 - Ø125 mm

P1D cylinders with intermediate trunnion

There are three different types of intermediate trunnion in the P1D family. An intermediate trunnion for the P1D Standard placed in the centre or an optional location of the cylinder, or a flange mounted intermediate trunnion on the front or rear end cover that fits all P1D cylinders.

For the P1D, the intermediate trunnion is available among the cylinder mountings in position 17. If G or 7 appears in position 17, the position of the intermediate trunnion should be specified as a three-digit measurement in positions 18-20. 000 indicates a loose intermediate trunnion. If D or 6 appears in position 17, the intermediate trunnion is always centred on the cylinder (no measurement specified in positions 18-20).

For the version with optional location of the intermediate trunnion or loose intermediate trunnion, no choices can be made for positions 18-20 since they are used for the XV dimension.

1	2	3	4	5	6	7	8	9	10	11	12	13	14	15	16	17	18	19	20
P	1	D	-	T	0	4	0	M	S	-	0	3	2	0	N	G	N	N	N

Cylinder mountings		
90°	0°	90° = shaft square to, 0° = shaft in line with ports ⁵⁾
D	6	Trunnion MT4, mid position ⁶⁾
G	7	Trunnion MT4, optional pos. (XV-meas. pos 18-20) ⁷⁾

For XV position > 999mm consult your local sales support

5) Shaft or pivots square to or in line with the cylinder ports.

6) Mid position means NNN for digits in position 18-20.

7) For XV-measure (from the piston rod thread according to ISO to the centre of the pivots) stated in mm in positions 18-20

Example of centred trunnion

P1D-T050MS-0250NDNNN P1D rod cylinder with intermediate trunnion installed in centre of cylinder.

P1D-T Pneumatic ISO Cylinders - Ø32 - Ø125 mm

Extended piston rod

All cylinders in the P1D family can be ordered with extended piston rod, for all piston rod materials. To make it possible to combine piston rod extension with all the functions and properties in the P1D system, the three positions which

normally specify cylinder bore are used to specify both bore and extension. When ordering a P1D cylinder with extended piston rod, specify this as below.

1	2	3	4	5	6	7	8	9	10	11	12	13	14	15
P	1	D	-	T	K	R	5	M	S	-	0	3	2	0

Cylinder bore mm	
K	32
L	40
M	50
N	63
P	80
Q	100
R	125

Piston rod extension			
E.g. KR5 = Cylinder bore 32 mm with piston rod extension = 255 mm			
01-99	1-99	N0-N9	220-229
A0-A9	100-109	P0-P9	230-239
B0-B9	110-119	Q0-Q9	240-249
C0-C9	120-129	R0-R9	250-259
D0-D9	130-139	S0-S9	260-269
E0-E9	140-149	T0-T9	270-279
F0-F9	150-159	U0-U9	280-289
G0-G9	160-169	V0-V9	290-299
H0-H9	170-179	W0-W9	300-309
J0-J9	180-189	X0-X9	310-319
K0-K9	190-199	Y0-Y9	320-329
L0-L9	200-209	Z0-Z9	330-339
M0-M9	210-219	Longer on request	

The maximum extended piston rod length that can be specified by the order key is 339 mm. If a longer extended piston rod is needed please consult your local sales support.

By changing from 032 to KR5, the cylinder has been given a 255 mm extended piston rod. At the same time, the cylinder can be specified with all functions and properties in the other digits.

Example of an extended piston rod

P1D-TK45MS-0200 P1D cylinder, bore 32 mm, with a 45 mm extended piston rod.

Piston rod in alternative materials

P1D has a polished stainless steel piston rod as standard. If you want a different material and/or surface treatment, please order this in combination with seal material in position 10.

Piston rod nuts are supplied in zinc plated steel as standard, but stainless steel piston rod nuts are always supplied for P1D Ultra & Pro Clean. If an alternative material is used, the piston rod nut is always supplied in the same material.

1	2	3	4	5	6	7	8	9	10	11	12	13	14	15
P	1	D	-	T	0	3	2	M	S	-	0	1	0	0

Piston rod material				Seals
Stainless steel	Chromium-plated steel	Acid-proof steel	Chrom.-pl. stainless steel	
S	C	M	R	Standard -20 °C to +80 °C.

Example of piston rod material

P1D-T032MS-0100 P1D cylinder, bore 32 mm, with stainless steel piston rod (standard)

P1D-T Pneumatic ISO Cylinders - Ø32 - Ø125 mm

Through piston rod

All P1D cylinders can be ordered with a through piston rod. Order this design in position 9 in combination with the scraper ring system as below.

1	2	3	4	5	6	7	8	9	10	11	12	13	14	15
P	1	D	-	T	0	3	2	F	S	-	0	1	0	0

End cover screws						Function
Standard			Stainless steel ²²⁾			
Std scraper	HDPE scraper ²³⁾	FPM scraper ²⁶⁾	Std scraper	HDPE scraper ²³⁾	FPM scraper ²⁶⁾	
M	D	V	A	H	W	Double-acting
F	E	B	G	Y	Z	Double-acting through rod

22) If stainless steel end cover screws are selected, the piston rod nuts are also supplied in stainless steel.

23) For dry rod operation.

26) FPM scraper should be chosen for higher chemical resistance on standard temperature versions only.

Example of through piston rod

P1D-T032FS-0100 P1D cylinder, bore 32 mm, with through piston rod.

Operation with a dry piston rod

The seal system for operation with a dry piston rod (HDPE scraper) is available as an option for all P1D cylinders except high and low temperature version and the hydraulic model.

Order this function by specifying letter D in position 9 (double acting cylinder) or E (double acting cylinder with through piston rod). Specify the code for the seal system in either the 15 or 20 digit part number.

1	2	3	4	5	6	7	8	9	10	11	12	13	14	15
P	1	D	-	T	0	8	0	D	S	-*	0	2	0	0

End cover screws						Function
Standard			Stainless steel ²²⁾			
Std scraper	HDPE scraper ²³⁾	FPM scraper ²⁶⁾	Std scraper	HDPE scraper ²³⁾	FPM scraper ²⁶⁾	
M	D	V	A	H	W	Double-acting
F	E	B	G	Y	Z	Double-acting through rod

22) If stainless steel end cover screws are selected, the piston rod nut(s) are also supplied in stainless steel.

23) For dry rod operation.

26) FPM scraper should be chosen for higher chemical resistance on standard temperature versions only.

Example of seal system for dry rod

P1D-T040DS-0200 P1D cylinder with seal system for dry operation.

3 and 4 positions Tie Rod cylinders (Ø32 to 125 mm)

Factory-fitted 3 and 4 positions cylinders can be ordered.
Through going tie-rods fix the two cylinders into a compact unit.

1	2	3	4	5	6	7	8	9	10	11	12	13	14	15	16	17	18	19	20
P	1	D	-	T	0	8	0	2	S	-	0	2	0	0	N	0	2	5	0

End cover screws						Function
Standard			Stainless steel ²²⁾			
Std scraper	Metal scraper ²⁵⁾	FPM scraper ²⁶⁾	Std scraper	Metal scraper ²⁵⁾	FPM scraper ²⁶⁾	
M	Q	V	A	S	W	Double acting
F	R	B	G	T	Z	Double acting through rod
2	4	8	-	-	-	3 and 4 position cylinders
C	J	L	-	-	-	Tandem

22) If stainless steel end cover screws are selected, the piston rod nuts are also supplied in stainless steel.

25) The metal scraper ring requires a hard-chromium plated piston rod

26) FPM scraper should be chosen for higher chemical resistance on standard temperature versions only.

Equal strokes – 3 positions cylinders

Specify letter T in position 5 (P1D-T) and number 2 in position 9 (if standard scraper ring)

Example of 3 and 4 positions cylinders

P1D-T0322S-0200 P1D Tie-Rod cylinder with 3 position with strokes 200 mm.

Unequal stroke – 4 positions cylinders

Specify letter T in position 5 (P1D-T) and number 2 in position 9 (if standard scraper ring)
Specify the shortest stroke in the ordinary positions 12, 13, 14, 15 and the longest stroke in positions 17, 18, 19, 20.

P1D-T0802S-0200N0250 P1D Tie-Rod cylinder with 4 position design with strokes 200 mm and 250 mm.

Tandem Tie Rod cylinders (Ø32 to 125 mm)

The P1D-T are available in tandem design i.e. two cylinders in series, for almost double force. Order with the letter C in position 9 (if standard scraper ring).

1	2	3	4	5	6	7	8	9	10	11	12	13	14	15
P	1	D	-	T	0	4	0	C	S	-	0	3	2	0

End cover screws						Function
Standard			Stainless steel ²²⁾			
Std scraper	Metal scraper ²⁵⁾	FPM scraper ²⁶⁾	Std scraper	Metal scraper ²⁵⁾	FPM scraper ²⁶⁾	
M	Q	V	A	S	W	Double acting
F	R	B	G	T	Z	Double acting through rod
2	4	8	-	-	-	3 and 4 position cylinders
C	J	L	-	-	-	Tandem

22) If stainless steel end cover screws are selected, the piston rod nuts are also supplied in stainless steel.

25) The metal scraper ring requires a hard-chromium plated piston rod.

26) FPM scraper should be chosen for higher chemical resistance on standard temperature versions only.

P1D-T Pneumatic ISO Cylinders - Ø32 - Ø125 mm

Double acting with stainless steel piston rod

- Bore sizes Ø32 - Ø125mm
- Stroke lengths 5 - 2800mm
- Magnetic piston as standard
- Adjustable cushioning as standard
- Standard temperature range



P1D-T Standard temperature, magnetic piston

Cyl. bore mm	Stroke mm	Order code
32 Conn. G1/8	25	P1D-T032MS-0025
	40	P1D-T032MS-0040
	50	P1D-T032MS-0050
	80	P1D-T032MS-0080
	100	P1D-T032MS-0100
	125	P1D-T032MS-0125
	160	P1D-T032MS-0160
	200	P1D-T032MS-0200
	250	P1D-T032MS-0250
	320	P1D-T032MS-0320
400	P1D-T032MS-0400	
500	P1D-T032MS-0500	
40 Conn. G1/4	25	P1D-T040MS-0025
	40	P1D-T040MS-0040
	50	P1D-T040MS-0050
	80	P1D-T040MS-0080
	100	P1D-T040MS-0100
	125	P1D-T040MS-0125
	160	P1D-T040MS-0160
	200	P1D-T040MS-0200
	250	P1D-T040MS-0250
	320	P1D-T040MS-0320
400	P1D-T040MS-0400	
500	P1D-T040MS-0500	
50 Conn. G1/4	25	P1D-T050MS-0025
	40	P1D-T050MS-0040
	50	P1D-T050MS-0050
	80	P1D-T050MS-0080
	100	P1D-T050MS-0100
	125	P1D-T050MS-0125
	160	P1D-T050MS-0160
	200	P1D-T050MS-0200
	250	P1D-T050MS-0250
	320	P1D-T050MS-0320
400	P1D-T050MS-0400	
500	P1D-T050MS-0500	
63 Conn. G3/8	25	P1D-T063MS-0025
	40	P1D-T063MS-0040
	50	P1D-T063MS-0050
	80	P1D-T063MS-0080
	100	P1D-T063MS-0100
	125	P1D-T063MS-0125
	160	P1D-T063MS-0160
	200	P1D-T063MS-0200
	250	P1D-T063MS-0250
	320	P1D-T063MS-0320
400	P1D-T063MS-0400	
500	P1D-T063MS-0500	

Cyl. bore mm	Stroke mm	Order code
80 Conn. G3/8	25	P1D-T080MS-0025
	40	P1D-T080MS-0040
	50	P1D-T080MS-0050
	80	P1D-T080MS-0080
	100	P1D-T080MS-0100
	125	P1D-T080MS-0125
	160	P1D-T080MS-0160
	200	P1D-T080MS-0200
	250	P1D-T080MS-0250
	320	P1D-T080MS-0320
400	P1D-T080MS-0400	
500	P1D-T080MS-0500	
100 Conn. G1/2	25	P1D-T100MS-0025
	40	P1D-T100MS-0040
	50	P1D-T100MS-0050
	80	P1D-T100MS-0080
	100	P1D-T100MS-0100
	125	P1D-T100MS-0125
	160	P1D-T100MS-0160
	200	P1D-T100MS-0200
	250	P1D-T100MS-0250
	320	P1D-T100MS-0320
400	P1D-T100MS-0400	
500	P1D-T100MS-0500	
125 Conn. G1/2	25	P1D-T125MS-0025
	40	P1D-T125MS-0040
	50	P1D-T125MS-0050
	80	P1D-T125MS-0080
	100	P1D-T125MS-0100
	125	P1D-T125MS-0125
	160	P1D-T125MS-0160
	200	P1D-T125MS-0200
	250	P1D-T125MS-0250
	320	P1D-T125MS-0320
400	P1D-T125MS-0400	
500	P1D-T125MS-0500	

The cylinders are supplied complete with one zinc plated steel piston rod nut.

P1D-T Tie rod Standard temperature

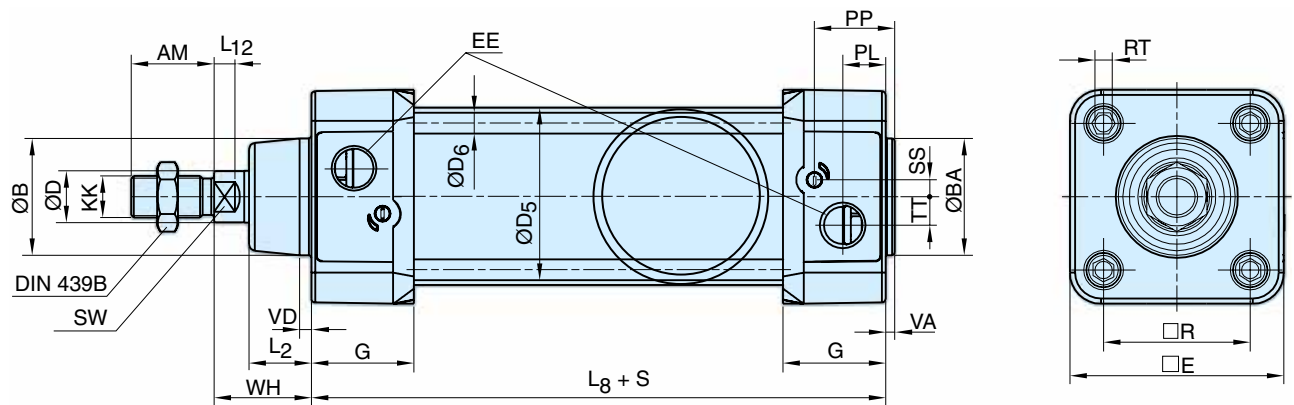

Internal piston rod thread

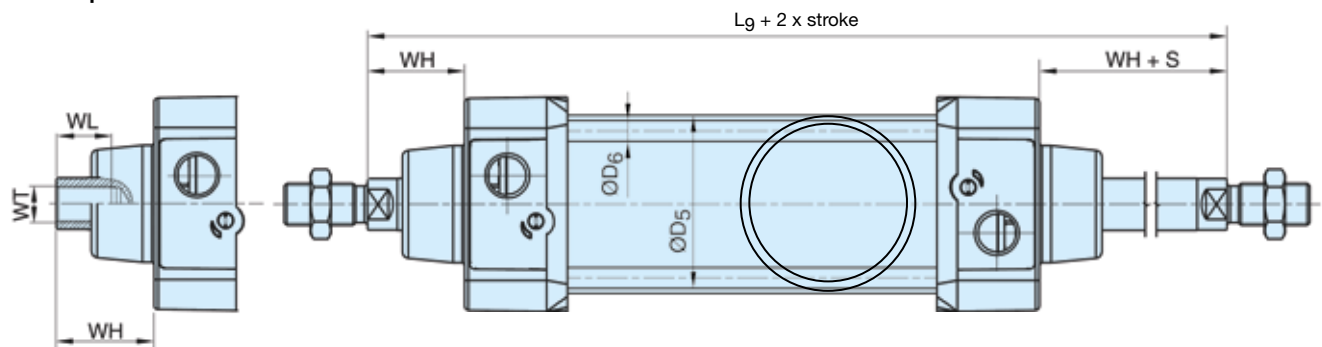

Dimensions

Cylinder bore mm	AM mm	B mm	BA mm	BG mm	D mm	D4 mm	E mm	EE mm	G mm	KK	L2 mm	L8 mm	L9 mm	L12 mm
32	22	30	30	16	12	45,0	50,0	G1/8	28,5	M10x1,25	16,0	94	146	6,0
40	24	35	35	16	16	52,0	57,4	G1/4	33,0	M12x1,25	19,0	105	165	6,5
50	32	40	40	16	20	60,7	69,4	G1/4	33,5	M16x1,5	24,0	106	180	8,0
63	32	45	45	16	20	71,5	82,4	G3/8	39,5	M16x1,5	24,0	121	195	8,0
80	40	45	45	17	25	86,7	99,4	G3/8	39,5	M20x1,5	30,0	128	220	10,0
100	40	55	55	17	25	106,7	116,0	G1/2	44,5	M20x1,5	32,4	138	240	14,0
125	54	60	60	20	32	134,0	139,0	G1/2	51,0	M27x2	45,0	160	290	18,0

Cylinder bore mm	OA mm	PL mm	PP mm	R mm	RT mm	SS mm	SW mm	TT mm	VA mm	VD mm	WH mm	WL mm	WT mm
32	6,0	13,0	21,8	32,5	M6	4,0	10	4,5	3,5	4,5	26	21	M8x1
40	6,0	14,0	21,9	38,0	M6	8,0	13	5,5	3,5	4,5	30	23	M10x1,25
50	8,0	14,0	23,0	46,5	M8	4,0	17	7,5	3,5	5,0	37	31	M14x1,5
63	8,0	16,4	27,4	56,5	M8	6,5	17	11,0	3,5	5,0	37	31	M14x1,5
80	6,0	16,0	30,5	72,0	M10	0	22	15,0	3,5	4,0	46	39	M18x1,5
100	6,0	18,0	35,8	89,0	M10	0	22	20,0	3,5	4,0	51	39	M18x1,5
125	8,0	28,0	40,5	110,0	M12	0	27	17,5	5,5	6,0	65	53	M24x2

S=Stroke

Tolerances

Cylinder bore mm	B	BA	L ₈ mm	L ₉ mm	R mm	Stroke tolerance up to stroke 500 mm	Stroke tolerance for stroke over 500 mm
32	d11	d11	±0,4	±2	±0,5	+0,3/+2,0	+0,3/+3,0
40	d11	d11	±0,7	±2	±0,5	+0,3/+2,0	+0,3/+3,0
50	d11	d11	±0,7	±2	±0,6	+0,3/+2,0	+0,3/+3,0
63	d11	d11	±0,8	±2	±0,7	+0,3/+2,0	+0,3/+3,0
80	d11	d11	±0,8	±3	±0,7	+0,3/+2,0	+0,3/+3,0
100	d11	d11	±1,0	±3	±0,7	+0,3/+2,0	+0,3/+3,0
125	d11	d11	±1,0	±3	±1,1	+0,3/+2,0	+0,3/+3,0

P1D-T Pneumatic ISO Cylinders - Ø32 - Ø125 mm**Double acting with stainless steel piston rod**

- Bore sizes Ø32 - Ø125mm
- Stroke lengths 5 - 2800mm
- Magnetic piston as standard
- Adjustable cushioning as standard
- Low & High temperature versions
- Hydraulic & Metal scraper versions

**P1D-T High temperature, no magnetic piston ***

Cyl. bore mm	Stroke mm	Order code
32 Conn. G1/8	25	P1D-T032MF-0025
	40	P1D-T032MF-0040
	50	P1D-T032MF-0050
	80	P1D-T032MF-0080
	100	P1D-T032MF-0100
	125	P1D-T032MF-0125
	160	P1D-T032MF-0160
	200	P1D-T032MF-0200
	250	P1D-T032MF-0250
	320	P1D-T032MF-0320
400	P1D-T032MF-0400	
500	P1D-T032MF-0500	
40 Conn. G1/4	25	P1D-T040MF-0025
	40	P1D-T040MF-0040
	50	P1D-T040MF-0050
	80	P1D-T040MF-0080
	100	P1D-T040MF-0100
	125	P1D-T040MF-0125
	160	P1D-T040MF-0160
	200	P1D-T040MF-0200
	250	P1D-T040MF-0250
	320	P1D-T040MF-0320
400	P1D-T040MF-0400	
500	P1D-T040MF-0500	
50 Conn. G1/4	25	P1D-T050MF-0025
	40	P1D-T050MF-0040
	50	P1D-T050MF-0050
	80	P1D-T050MF-0080
	100	P1D-T050MF-0100
	125	P1D-T050MF-0125
	160	P1D-T050MF-0160
	200	P1D-T050MF-0200
	250	P1D-T050MF-0250
	320	P1D-T050MF-0320
400	P1D-T050MF-0400	
500	P1D-T050MF-0500	
63 Conn. G3/8	25	P1D-T063MF-0025
	40	P1D-T063MF-0040
	50	P1D-T063MF-0050
	80	P1D-T063MF-0080
	100	P1D-T063MF-0100
	125	P1D-T063MF-0125
	160	P1D-T063MF-0160
	200	P1D-T063MF-0200
	250	P1D-T063MF-0250
	320	P1D-T063MF-0320
400	P1D-T063MF-0400	
500	P1D-T063MF-0500	

Cyl. bore mm	Stroke mm	Order code
80 Conn. G3/8	25	P1D-T080MF-0025
	40	P1D-T080MF-0040
	50	P1D-T080MF-0050
	80	P1D-T080MF-0080
	100	P1D-T080MF-0100
	125	P1D-T080MF-0125
	160	P1D-T080MF-0160
	200	P1D-T080MF-0200
	250	P1D-T080MF-0250
	320	P1D-T080MF-0320
400	P1D-T080MF-0400	
500	P1D-T080MF-0500	
100 Conn. G1/2	25	P1D-T100MF-0025
	40	P1D-T100MF-0040
	50	P1D-T100MF-0050
	80	P1D-T100MF-0080
	100	P1D-T100MF-0100
	125	P1D-T100MF-0125
	160	P1D-T100MF-0160
	200	P1D-T100MF-0200
	250	P1D-T100MF-0250
	320	P1D-T100MF-0320
400	P1D-T100MF-0400	
500	P1D-T100MF-0500	
125 Conn. G1/2	25	P1D-T125MF-0025
	40	P1D-T125MF-0040
	50	P1D-T125MF-0050
	80	P1D-T125MF-0080
	100	P1D-T125MF-0100
	125	P1D-T125MF-0125
	160	P1D-T125MF-0160
	200	P1D-T125MF-0200
	250	P1D-T125MF-0250
	320	P1D-T125MF-0320
400	P1D-T125MF-0400	
500	P1D-T125MF-0500	

The cylinders are supplied complete with one zinc plated steel piston rod nut.

Note: * Change **MF** to **ML** for low temperature range magnetic piston, **QC** for standard temp with metal scraper, **MJ** for hydraulic version not magnetic

P1D-T Pneumatic ISO Cylinders - Ø32 - Ø125 mm

P1D-T High, low temp, hydraulic and metal scraper options

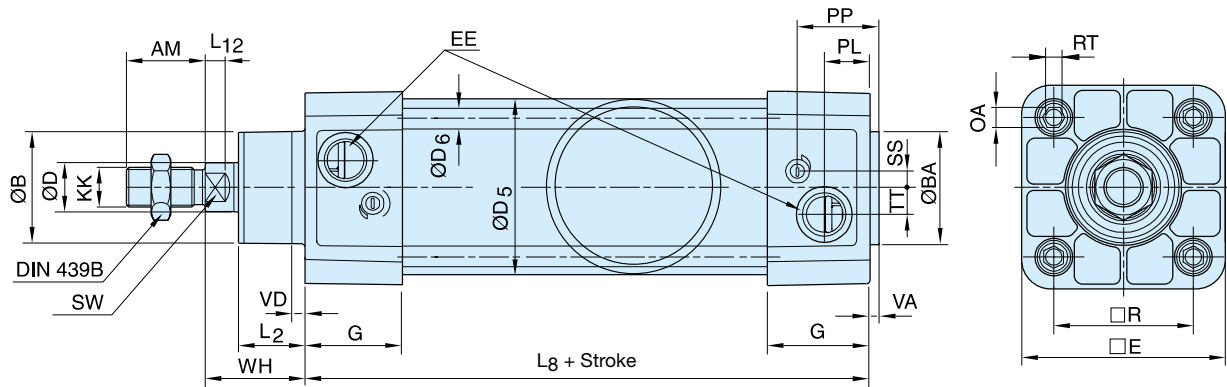

Internal piston rod thread

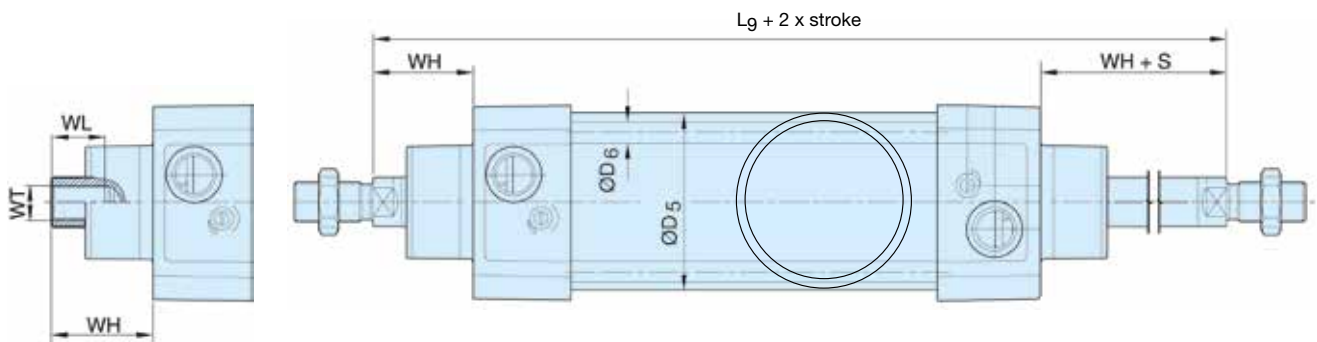

Dimensions

Cylinder bore mm	AM mm	B mm	BA mm	BG mm	D mm	D4 mm	E mm	EE mm	G mm	KK	L2 mm	L8 mm	L9 mm	L12 mm
32	22	30	30	16	12	45,0	48,0	G1/8	28,5	M10x1,25	16,8	94	146	6,0
40	24	35	35	16	16	52,0	53,5	G1/4	33,0	M12x1,25	19,0	105	165	6,5
50	32	40	40	16	20	60,7	65,2	G1/4	33,5	M16x1,5	24,0	106	180	8,0
63	32	45	45	16	20	71,5	75,5	G3/8	39,5	M16x1,5	24,3	121	195	8,0
80	40	45	45	17	25	86,7	95,0	G3/8	39,5	M20x1,5	30,0	128	220	10,0
100	40	55	55	17	25	106,7	114,0	G1/2	44,5	M20x1,5	34,0	138	240	14,0
125	54	60	60	20	32	134,0	139,0	G1/2	51,0	M27x2	45,0	160	290	18,0

Cylinder bore mm	OA mm	PL mm	PP mm	R mm	RT	SS mm	SW mm	TT mm	VA mm	VD mm	WH mm	WL mm	WT
32	6,0	14,0	24,2	32,5	M6	5,5	10	4,2	3,5	4,5	26	21	M8x1
40	6,0	16,0	27,5	38,0	M6	8,0	13	5,5	3,5	4,5	30	23	M10x1,25
50	8,0	14,0	29,3	46,5	M8	9,0	17	7,5	3,5	4,5	37	31	M14x1,5
63	8,0	16,6	30,8	56,5	M8	6,5	17	10,0	3,5	4,5	37	31	M14x1,5
80	6,0	16,8	33,5	72,0	M10	0	22	11,5	3,5	4,5	46	39	M18x1,5
100	6,0	20,5	37,5	89,0	M10	0	22	14,5	3,5	4,5	51	39	M18x1,5
125	8,0	23,3	45,8	110,0	M12	0	27	15,0	5,5	6,5	65	53	M24x2

S=Stroke

Tolerances

Cylinder bore mm	B	BA	L ₈ mm	L ₉ mm	R mm	Stroke tolerance up to stroke 500 mm	Stroke tolerance for stroke over 500 mm
32	d11	d11	±0,4	±2	±0,5	+0,3/+2,0	+0,3/+3,0
40	d11	d11	±0,7	±2	±0,5	+0,3/+2,0	+0,3/+3,0
50	d11	d11	±0,7	±2	±0,6	+0,3/+2,0	+0,3/+3,0
63	d11	d11	±0,8	±2	±0,7	+0,3/+2,0	+0,3/+3,0
80	d11	d11	±0,8	±3	±0,7	+0,3/+2,0	+0,3/+3,0
100	d11	d11	±1,0	±3	±0,7	+0,3/+2,0	+0,3/+3,0
125	d11	d11	±1,0	±3	±1,1	+0,3/+2,0	+0,3/+3,0

P1D-T Pneumatic ISO Cylinders - Ø32 - Ø125 mm

3 and 4 positions cylinders

This type of cylinder function consists of two cylinders installed back to back. Two cylinders with the same stroke give a 3 positions cylinder with a symmetrical centre position, whereas different strokes give a 4 positions cylinder where the two central positions can be calculated from the different stroke lengths.

3 and 4 positions cylinders can be ordered in two ways.



Factory-fitted

Tie-rod P1D cylinders are completed at the factory and are joined together as one unit by special tie-rods, see position 9 in the order key.

Installation kit

There is an installation kit for cylinder bores 32 – 100 mm which makes it possible to join any two P1D cylinders together at any time, to make a 3 or 4 positions cylinders.

Cyl. bore mm	E mm	TG mm	ØFB mm	MF mm	A mm	ØBA mm	Weight Kg	Order code
32	50	32,5	6,5	5	16	30	0,060	P1E-6KB0
40	60	38,0	6,5	5	16	35	0,078	P1E-6LB0
50	66	46,5	8,5	6	20	40	0,162	P1E-6MB0
63	80	56,5	8,5	6	20	45	0,194	P1E-6NB0
80	100	72,0	10,5	8	25	45	0,450	P1E-6PB0
100	118	89,0	10,5	8	25	55	0,672	P1E-6QB0

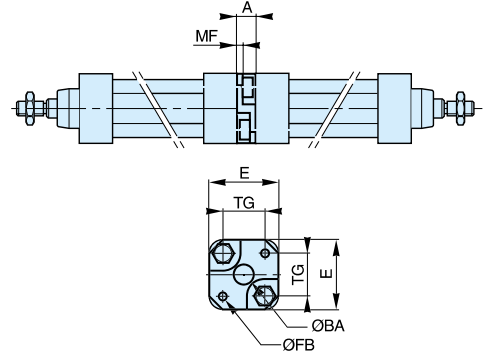

Cylinder bore. mm	B mm	2 x VA mm
32	247	7
40	277	7
50	293	7
63	323	7
80	355	7
100	385	7
125	461	11

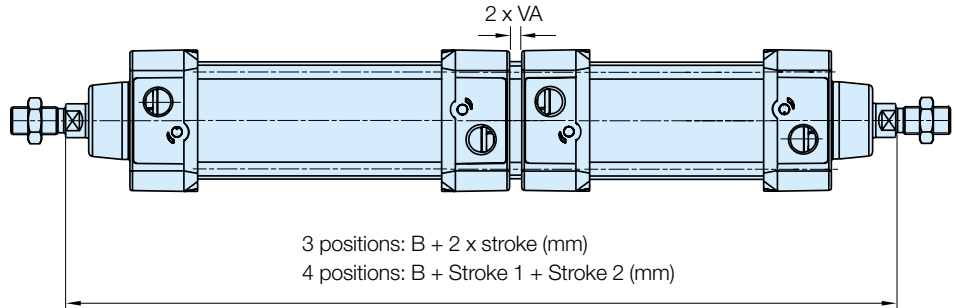

Tandem version

The P1D is also available as a tandem cylinder, i.e. two cylinders connected in series. This cylinder unit has almost twice the force, which is a great advantage in restricted spaces. Tandem cylinders are available as tie-rod cylinders, P1D-T, in all bores Ø32-125 mm.



Cylinder bore. mm	C mm	WA mm
32	221.5	7.5
40	247.5	7.5
50	256.5	7.5
63	286.5	7.5
80	309.5	7.5
100	334.5	7.5
125	396.5	11.5

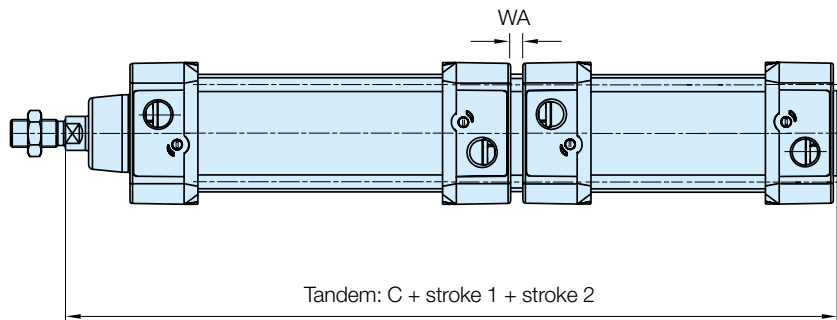

Order Key Code (Model code with 20 digits used only for the trunnion , female thread on the piston rod or to specify second cylinder stroke)

15 digit order code															20 digit order code				
1	2	3	4	5	6	7	8	9	10	11	12	13	14	15	16	17	18	19	20
P	1	D	-	T	0	3	2	M	F	-	0	1	0	0	N	D	N	N	N

4	6-7-8	6	7-8
Cylinder type	Cylinder bore mm	Rod extension only	
- Standard with cushioning and magnetic piston	032	K	32
F Standard with cushioning without magnet piston	040	L	40
	050	M	50
	063	N	63
	080	P	80
	100	Q	100
	125	R	125

9
End cover screws
Standard Stainless steel
Std scraper Metal scraper ³ Std scraper Metal scraper ³
M Q A S
F R G T
2 4 - -
C J - -
Function
Double acting
Double acting through rod
3 and 4 position cylinders
Tandem

10
Piston rod material
Stainless steel Chromium-plated steel ¹⁾ Acid-proof steel Chromium plated stainless steel ¹⁾
S C M R
F G N D
L K P E
- J - Z
Seals
Standard temperature -20°C to +80°C. ²⁾
High temperature -10°C to +150°C. No magnetic function.
Low temperature -40°C to +80°C.
Low pressure hydraulic -20°C to +80°C.

17-18-19-20
Intermediate trunnion
90° 0° Pivots Vs Air Ports
D 6
G 7
N and stroke of the second cylinder if different otherwise use 15 digits model code

12-13-14-15
Stroke (mm) e.g. 0100 = 100 mm
Optional stroke lengths up to 2800 mm. Standard strokes see table below

19
Piston rod thread
6 Internal piston rod thread

¹⁾ In combination with metal scraper
²⁾ Piston made of acetal. for high, low temp & Hydraulic version piston made of aluminium

Standard strokes

Standard strokes for all P1D-T cylinders comply with ISO 4393.
 Non standard strokes up to 2800 mm.

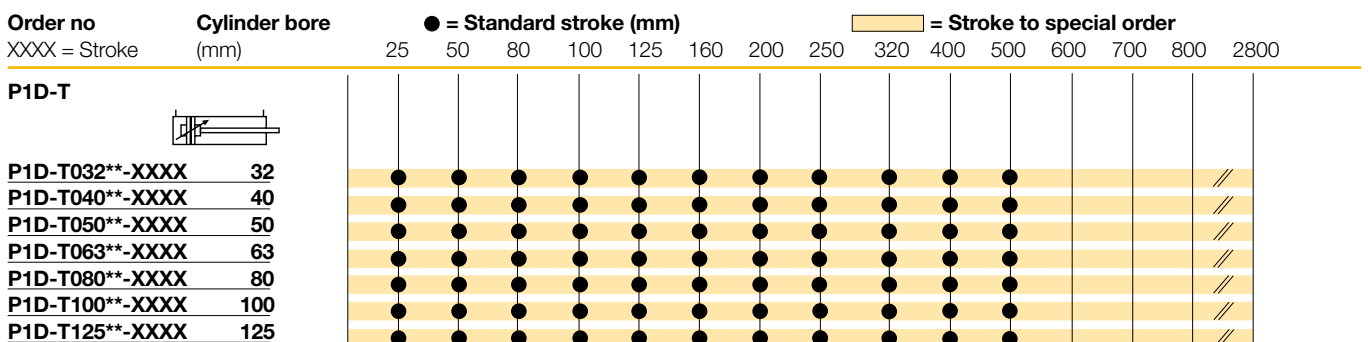

P1D-T Pneumatic ISO Cylinders - Ø160 - Ø320 mm

Double acting with stainless steel piston rod

- Bore sizes Ø160 - Ø320mm
- Stroke lengths 10 - 2000mm
- Magnetic piston as standard
- Adjustable cushioning as standard
- High temperature version
- ATEX version (add-EXNN to the order code)



P1D-T Standard temperature, magnetic piston

Cyl. bore mm	Stroke mm	Order code
160 Conn. G3/4	50	P1D-T160MS-0050
	80	P1D-T160MS-0080
	100	P1D-T160MS-0100
	125	P1D-T160MS-0125
	160	P1D-T160MS-0160
	200	P1D-T160MS-0200
	250	P1D-T160MS-0250
	320	P1D-T160MS-0320
	400	P1D-T160MS-0400
	500	P1D-T160MS-0500
800	P1D-T160MS-0800	
1000	P1D-T160MS-1000	

200 Conn. G3/4	50	P1D-T200MS-0050
	80	P1D-T200MS-0080
	100	P1D-T200MS-0100
	125	P1D-T200MS-0125
	160	P1D-T200MS-0160
	200	P1D-T200MS-0200
	250	P1D-T200MS-0250
	320	P1D-T200MS-0320
	400	P1D-T200MS-0400
	500	P1D-T200MS-0500
800	P1D-T200MS-0800	
1000	P1D-T200MS-1000	

Cyl. bore mm	Stroke mm	Order code
250 Conn. G1	50	P1D-T250MS-0050
	80	P1D-T250MS-0080
	100	P1D-T250MS-0100
	125	P1D-T250MS-0125
	160	P1D-T250MS-0160
	200	P1D-T250MS-0200
	250	P1D-T250MS-0250
	320	P1D-T250MS-0320
	400	P1D-T250MS-0400
	500	P1D-T250MS-0500
800	P1D-T250MS-0800	
1000	P1D-T250MS-1000	

320 Conn. G1	50	P1D-T320MS-0050
	80	P1D-T320MS-0080
	100	P1D-T320MS-0100
	125	P1D-T320MS-0125
	160	P1D-T320MS-0160
	200	P1D-T320MS-0200
	250	P1D-T320MS-0250
	320	P1D-T320MS-0320
	400	P1D-T320MS-0400
	500	P1D-T320MS-0500
800	P1D-T320MS-0800	
1000	P1D-T320MS-1000	

The cylinders are supplied complete with one zinc plated steel piston rod nut.

Note: * Change MS to MF for high temperature range no magnetic piston,
QC for standard temp with metal scraper

P1D-T Tie rod

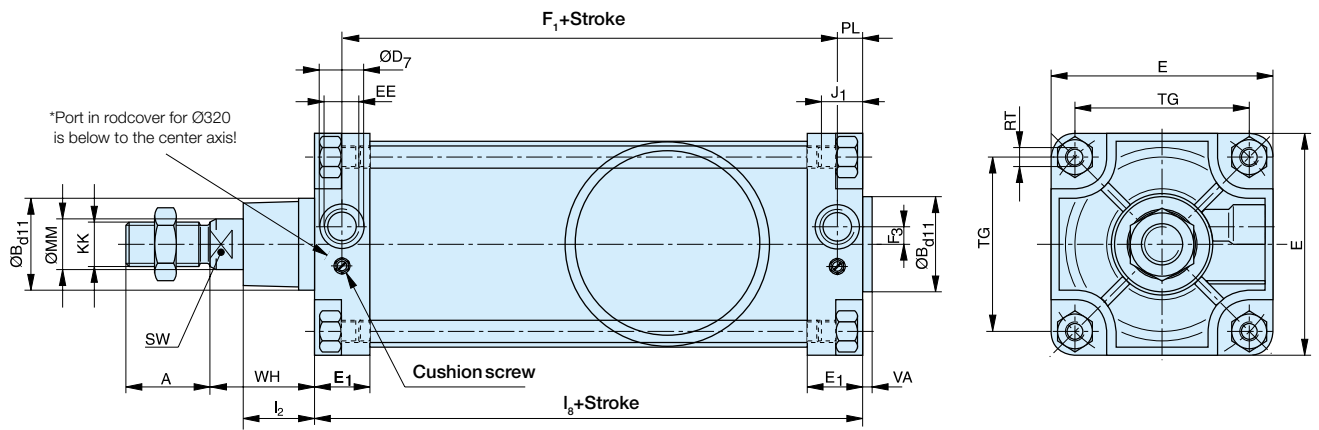

Note *: for bore size 320mm, front air port is on the bottom of the axis of the cylinder and the cushioning screw on the top

Dimensions (mm)

Cyl. Ø	A	ØB _{d11}	ØD ₇	E	E ₁	F ₁ + Stroke	F ₃	J ₁ max.	I ₂	I ₈ + Stroke	EE	KK	MM	PL	RT	SW	TG	VA	WH
160	72	65	33	180	45	130	11	23	50	180	G3/4	M36x2	40	25	M16	36	140	6	80
200	72	75	33	220	45	130	15	23	60	180	G3/4	M36x2	40	25	M16	36	175	6	95
250	84	90	40	280	64	136	21	27	70	200	G1	M42x2	50	32	M20	46	280	10	105
320	96	110	-	340	56	164	-20*/20	28	89,5	220	G1	M48x2	63	28	M24	55	340	10	120

Tolerances

Cylinder bore mm	L ₈ mm	TG mm	Stroke tolerance up to stroke 500 mm	Stroke tolerance for stroke over 500 mm
160	±1,1	±1,1	+0,3/+2,0	+0,3/+3,0
200	±1,6	±1,1	+0,3/+2,0	+0,3/+3,0
250	±1,6	±1,5	+0,3/+2,0	+0,3/+3,0
320	±2,2	±1,5	+0,3/+2,0	+0,3/+3,0

Order Key Code (Model code with 20 digits used only for the trunnion option or for the ATEX version)

15 digit order code

1 2 3 4 5 6 7 8 9 10 11 12 13 14 15

P 1 D - T 1 6 0 M S - 0 5 0 0

20 digit order code

16 17 18 19 20

N D N N N

4

Cylinder type

-	Standard with cushioning and magnetic piston
F	Standard with cushioning without magnet piston

9

Function

M	Standard scraper
Q	Metallic scraper
V	FPM scraper
F	Thru rod, standard scraper
R	Thru rod, metallic scraper
B	Thru rod, FPM scraper

12-13-14-15

Stroke (mm) e.g. 0100 = 100 mm

Optional stroke lengths up to 2000 mm. Standard strokes see table below.

6-7-8

Cylinder bore mm

160
200
250
320

10

Piston rod Material		Seals
Stainless steel	Chromium plated steel	
	S	C
F	G	High temperature version -10°C to +150°C. No magnetic function, keep - symbol in digit 4

17-18-19-20

Intermediate trunnion

90°	0°	Pivots Vs Air Ports
D	6	Centre trunnion MT4, mid position (NNN digits 18-19-20)
G	7	Trunnion MT4, optional pos. (XV-meas. digits 18-19-20)

16-17-18-19-20

ATEX version e.g. P1D-T160MS-0500-EXNN

-EXNN	According to ATEX
-------	-------------------

CE Ex II 2GD c T4 120 °C

Standard strokes

Standard strokes for all P1D-T cylinders comply with ISO 4393. Non standard strokes up to 2000 mm.

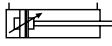
Order no	Cylinder bore (mm)	● = Standard stroke (mm)										= Stroke to special order		
XXXX = Stroke	(mm)	50	80	100	125	160	200	250	320	400	500	800	1000	2000
P1D-T														
P1D-T160MS-XXXX	160	●	●	●	●	●	●	●	●	●	●	●	●	●
P1D-T200MS-XXXX	200	●	●	●	●	●	●	●	●	●	●	●	●	●
P1D-T250MS-XXXX	250	●	●	●	●	●	●	●	●	●	●	●	●	●
P1D-T320MS-XXXX	320	●	●	●	●	●	●	●	●	●	●	●	●	●

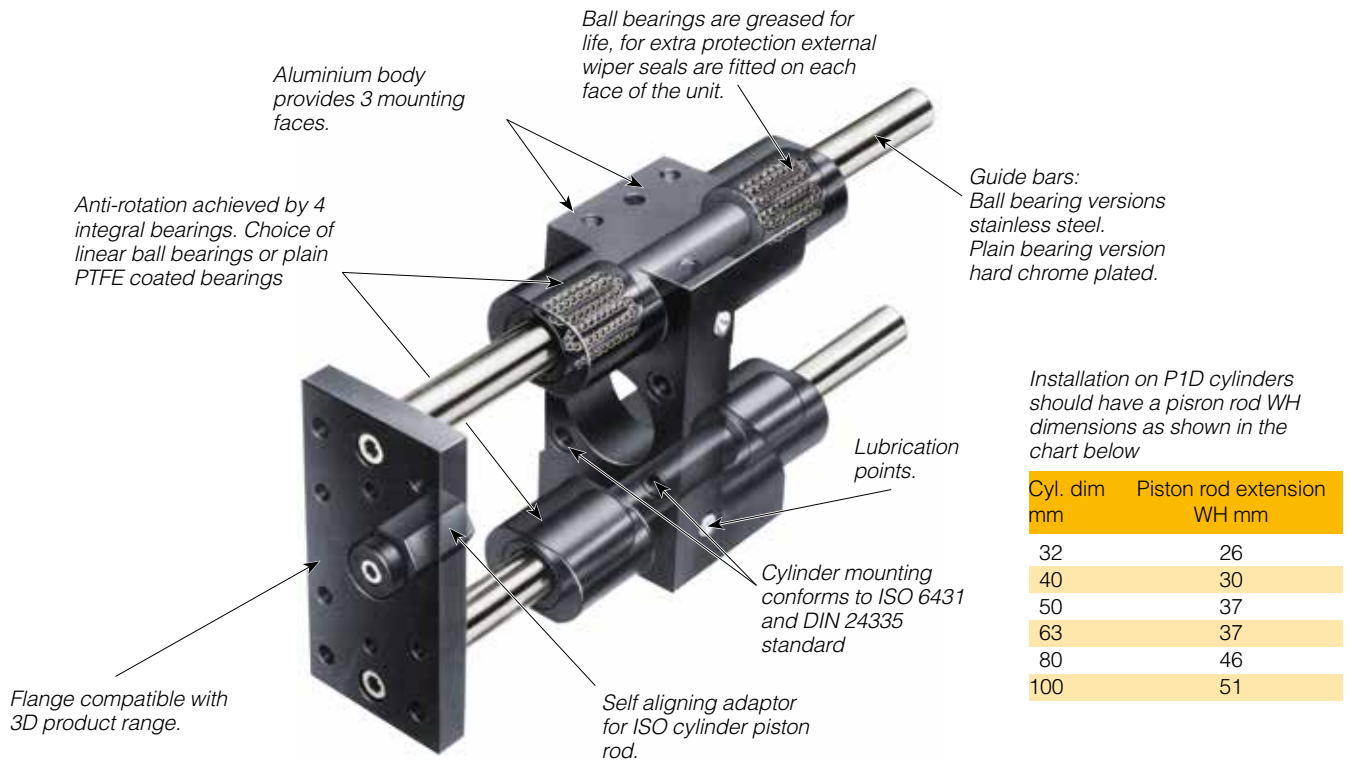

Installation on P1D cylinders should have a piston rod WH dimensions as shown in the chart below

Cyl. dim mm	Piston rod extension WH mm
32	26
40	30
50	37
63	37
80	46
100	51

P1D with rod guidance modules

The P1D series cylinders can be equipped with an external guiding device to prevent the piston rod from turning. The factory fitted guide gives a guided piston movement and enables the cylinder to take up turning moments on the piston rod, as well as greater transverse forces. The rod guidance is available with plain bearings or linear ball bearings and with H or U style. The bracket, which has pre-drilled mounting holes, is connected to the piston rod by means of a flexo coupling, which prevents the build-up of stresses in the cylinder. Guidance modules are available for bores from 32 to 100 mm, and standard stroke lengths from 25 to 250 mm. Special stroke lengths up to 500 mm can also be obtained.

Technical data

Load See diagram on next page
 Working temperature -20 °C to +80 °C

Material specifications

Body Anodised aluminium
 Guide bars, H style Stainless steel for ball bearing chrome plated for plain bearing
 Front plate Anodised aluminium
 Guide bars, U style Stainless steel
 Front plate Zinc-plated steel
 Bearings Plain bearings
 Linear ball bearings

Order code key for rod guidance modules

P1E - 4KRH - 0100

Cylinder version	Bore size mm	Guide module type	Stroke length (mm)
E ISO cylinders	K 32	H H style, ball bearings	Same as for the cylinder e.g. 0100 = 100 mm.
	L 40	J H style, plain bearings	
	M 50	K U style, plain bearings	
	N 63		
	P 80		
	Q 100		

Technical information 'H style'

Rod guide with ball bearings

Maximum load carried

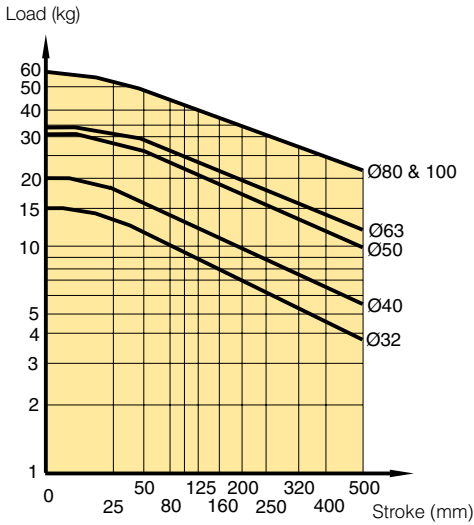

Graphs established at mid point of stroke

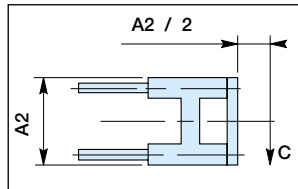

Rod guide with plain bearings

Maximum load carried

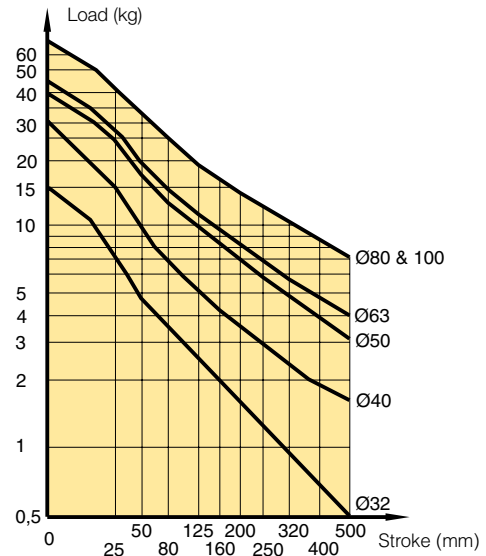

Maximum deflection/max load

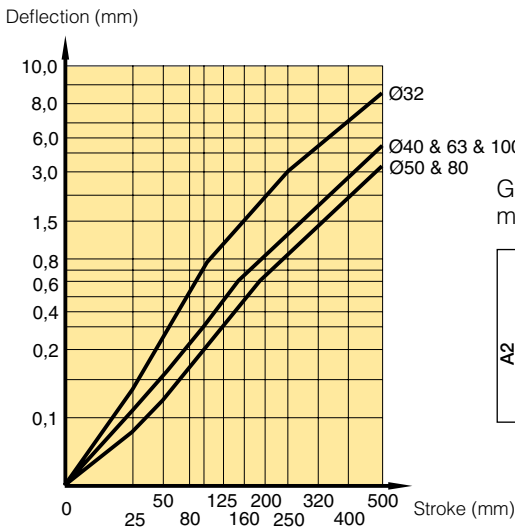

Graphs established at mid point of stroke

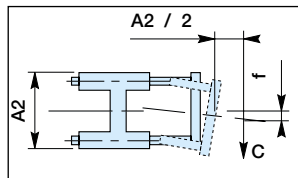

Maximum deflection/max load

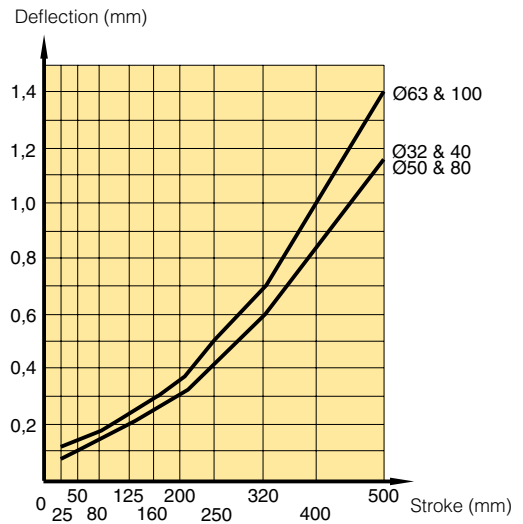

Maximum permissible torque (Nm)

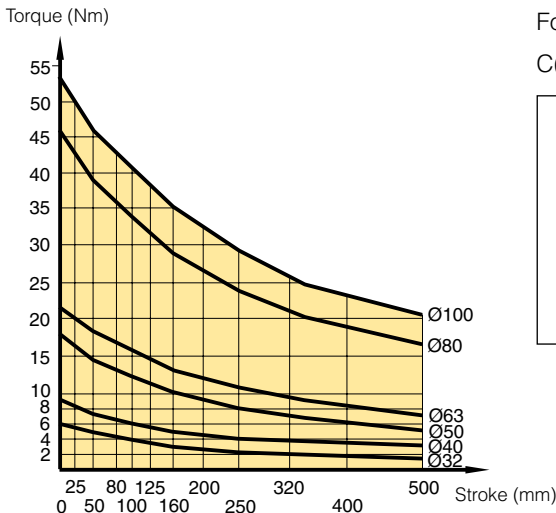

Formula:

$$C(Nm) = F(N) \times L(m)$$

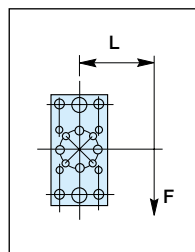

Maximum permissible torque (Nm)

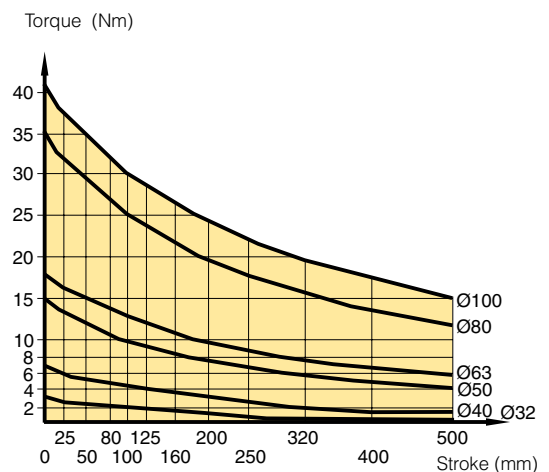

H style guidance modules

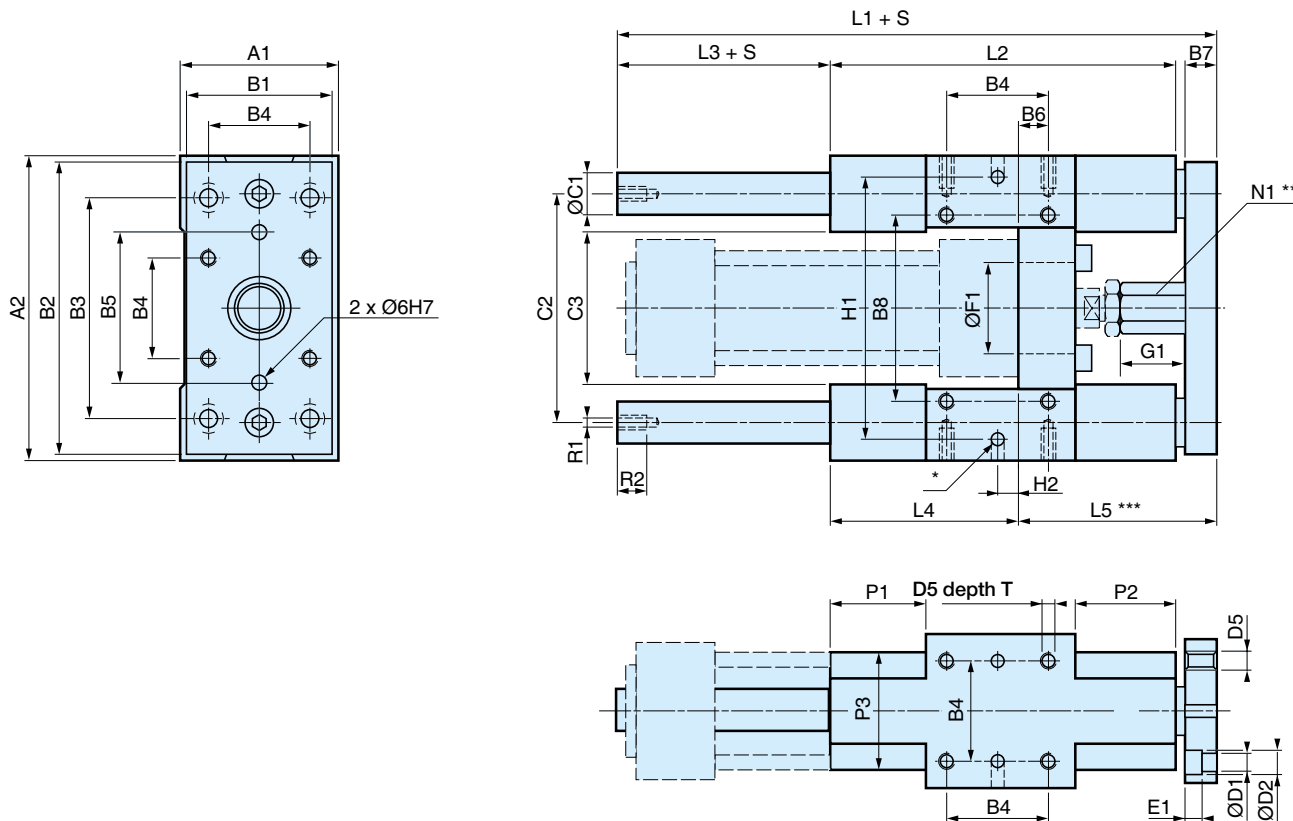

Dimensions (mm)

Cyl. bore mm	A ₁ mm	A ₂ mm	B ₁ mm	B ₂ mm	B ₃ mm	B ₄ mm	B ₅ mm	B ₆ mm	B ₇ mm	B ₈ mm	ØC ₁ mm	C ₂ mm	C ₃ mm	ØD ₁ mm	ØD ₂ mm	D ₅
32	50	97	45	90	78	32,5	50	4,2	12	61	12	73,5	50	6,6	11	M6
40	58	115	54	110	84	38,0	54	11,0	12	69	16	86,5	58	6,6	11	M6
50	70	137	63	130	100	46,5	72	18,8	15	85	20	103,5	70	8,4	15	M8
63	85	152	80	145	105	56,5	82	15,0	15	100	20	118,5	83	8,4	15	M8
80	105	189	100	180	130	72,0	106	21,0	20	130	25	147,0	102	10,5	18	M10
100	130	213	120	200	150	89,0	131	24,5	20	150	25	171,5	125	10,5	18	M10

Cyl. bore mm	E ₁ mm	ØF ₁ ^{+0,1/0} mm	G ₁ mm	L ₁ mm	L ₂ mm	L ₃ mm	L ₄ mm	L ₅ mm	N ₁ mm	P ₁ ^{±1} mm	P ₂ ^{±1} mm	P ₃ mm	R ₁ mm	R ₂ mm	W mm
32	7	30	17	150	120	15	71	64	17	36	31	40	M6	11	5
40	7	35	24	170	130	25	71	74	17	36	36	44	M6	11	6
50	9	40	27	197	150	24	79	89	24	42	44	50	M8	16	8
63	9	45	27	222	180	24	109	89	24	58	44	60	M8	16	8
80	11	45	32	247	200	24	113	110	30	50	52	70	M10	16	10
100	11	55	32	267	220	24	128	115	30	49	51	70	M10	16	10

Cyl. bore mm	H ₁ ^{±0,05} mm	H ₂ mm	T mm	Weight at 0 mm stroke kg	Supplement weight per 10 mm stroke kg
32	81	11,7	12	0,970	0,018
40	99	8,0	12	1,550	0,032
50	119	4,2	16	2,560	0,050
63	132	13,0	16	3,570	0,050
80	166	15,0	20	6,530	0,078
100	190	20,5	20	8,760	0,078

S = Stroke length

* 6 hole Ø6 H₇, depth 10^{+1/0}

** Hexagon profile

*** Min adjustment=0, max.=W



U style guidance modules

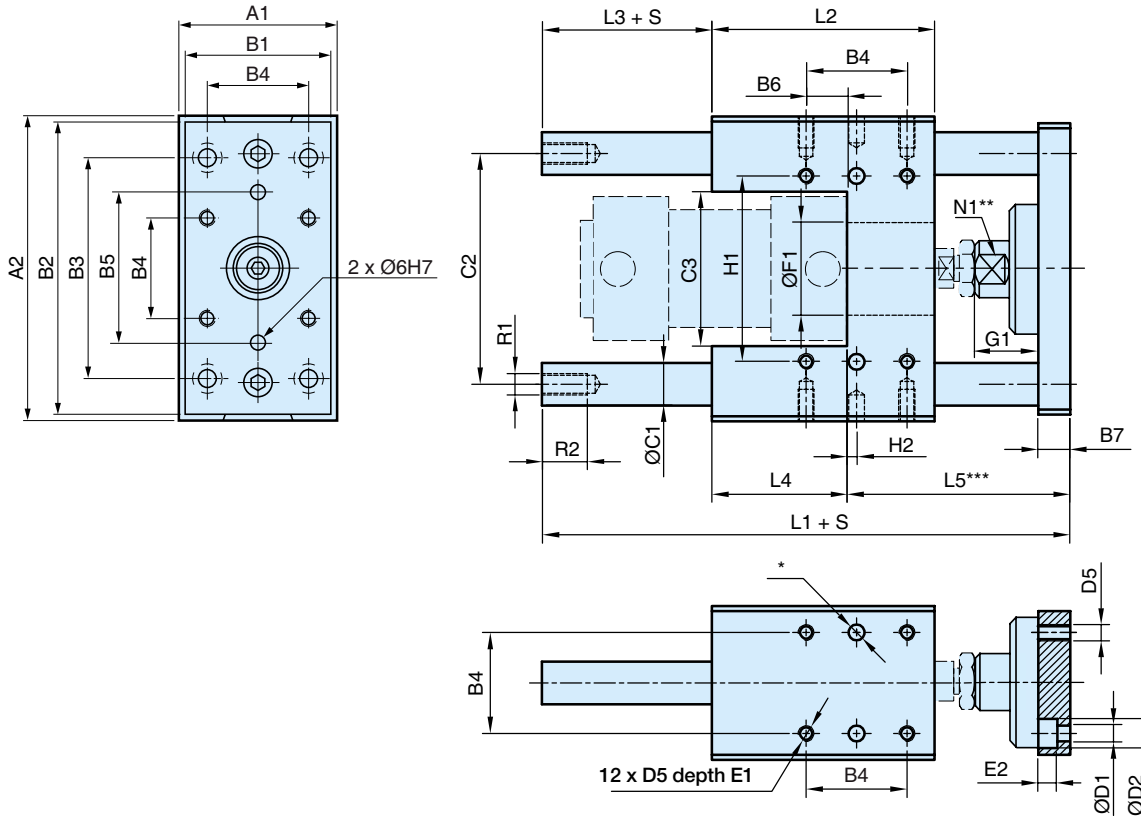

Dimensions (mm)

Cyl. bore. mm	A ₁ mm	A ₂ mm	B ₁ mm	B ₂ mm	B ₃ mm	B ₄ mm	B ₅ mm	B ₆ mm	B ₇ mm	C ₁ mm	C ₂ mm	C ₃ mm	D ₁ mm	D ₂ mm	D ₅
32	50	97	45	90	78	32,5	50	18,0	12	12	74	50	6,6	11	M6
40	58	115	54	110	84	38,0	54	15,5	12	16	87	58	6,6	11	M6
50	70	137	63	130	100	46,5	72	19,5	15	20	104	70	9,0	15	M8
63	85	152	80	145	105	56,5	82	29,5	15	20	119	85	9,0	15	M8
80	105	189	100	180	130	72,0	106	39,0	20	25	148	105	11,0	18	M10
100	130	213	120	200	150	89,0	131	53,5	20	25	172	130	11,0	18	M10

Cyl. bore. mm	E ₁ mm	E ₂ mm	Ø F ₁ ^{+0,1/0} mm	G ₁	L ₁ mm	L ₂ mm	L ₃ mm	L ₄ mm	L ₅ mm	N ₁ mm	R ₁ mm	R ₂	H ₁ ^{+0,05} mm	H ₂ mm	W ^{***} mm
32	10	6,5	30	30	133	72	14	44	75	13	M6	11	61	1,75	5
40	10	6,5	35	36	149	84	12	51	86	15	M8	12	69	3,50	5
50	13	9,0	40	42	175	100	12	60	103	22	M8	12	85	3,75	5
63	13	9,0	45	42	190	115	12	75	103	22	M8	12	100	1,25	5
80	16	11,0	45	49	238	162	0	112	126	27	M10	16	130	3,00	6
100	16	11,0	55	49	249	167	6	112	131	27	M10	16	150	8,50	6

Cyl. bore mm	Weight at 0 mm stroke kg	Supplement weight per 10 mm stroke kg
32	0,970	0,018
40	1,550	0,315
50	2,560	0,493
63	3,570	0,493
80	6,530	0,770
100	8,760	0,770

S = Stroke length

* 6 hole Ø6^{H7}, depth 10^{+1/0}

** Width of jaw

*** Min adjustment=0, max.=W

	Flange MF1/MF2 ¹	Foot brackets MS1 ²	Pivot bracket with rigid bearing AB7 ³	Swivel eye bracket MP6 ⁴	Clevis bracket MP2 ⁵
Ø 32	P1C-4KMB	P1C-4KMF	P1C-4KMDB	PD23843	P1C-4KMTB
Ø 40	P1C-4LMB	P1C-4LMF	P1C-4LMDB	PD23844	P1C-4LMTB
Ø 50	P1C-4MMB	P1C-4MMF	P1C-4MMDB	PD23845	P1C-4MMTB
Ø 63	P1C-4NMB	P1C-4NMF	P1C-4NMDB	PD23846	P1C-4NMTB
Ø 80	P1C-4PMB	P1C-4PMF	P1C-4PMDB	PD23847	P1C-4PMTB
Ø 100	P1C-4QMB	P1C-4QMF	P1C-4QMDB	PD23848	P1C-4QMTB
Ø 125	P1C-4RMB	P1C-4RMF	P1C-4RMDB	PD23849	P1C-4RMTB
Ø 160	PD23410	PD70512	P1C-4SMDB	PD23850	P1C-4SMTB
Ø 200	PD24924	PD24792	P1C-4TMDB	PD25766	P1C-4TMTB
Ø 250	PD25761	PD25758	P1C-4UMDC	PD25760	P1C-4UMTB
Ø 320	KL9140	KL9139	P1C-4VMDC	KL9136	P1C-4VMTB
	Clevis bracket MP4 ⁶	Clevis bracket AB6 ⁷	Pivot bracket with swivel bearing CS7 ⁸	3 and 4 positions flange JP1	Pivot brackets AT4 ¹⁰ for MT* trunnion
Ø 32	PD23412	P1C-4KMCB	KC5130	P1E-6KB0	PD23381
Ø 40	PD23413	P1C-4LMCB	KC5131	P1E-6LB0	PD23382
Ø 50	PD23414	P1C-4MMCB	KC5132	P1E-6MB0	PD23382
Ø 63	PD23415	P1C-4NMCB	KC5133	P1E-6NB0	PD23383
Ø 80	PD23416	P1C-4PMCB	KC5134	P1E-6PB0	PD23383
Ø 100	PD23417	P1C-4QMCB	KC5135	P1E-6QB0	PD23384
Ø 125	PD23418	P1C-4RMCB	KC5136		PD23384
Ø 160	PD22628				PD24425
Ø 200	PD24999				PD24425
Ø 250	PD25759				PD25763
Ø 320	KL9135				KL9130
	Flange trunnion MT5/MT6 ¹¹	Swivel rod eye AP6 ¹²	Clevis AP2 ¹³	Flexo coupling PM5 ¹⁴	Zinc-plated nut MR9 ¹⁵
Ø 32	P1D-4KMYF	P1C-4KRS	P1C-4KRC	P1C-4KRF	P14-4KRPZ
Ø 40	P1D-4LMYF	P1C-4LRS	P1C-4LRC	P1C-4LRF	P14-4LRPZ
Ø 50	P1D-4MMYF	P1C-4MRS	P1C-4MRC	P1C-4MRF	P14-4MRPZ
Ø 63	P1D-4NMYF	P1C-4MRS	P1C-4MRC	P1C-4MRF	P14-4MRPZ
Ø 80	P1D-4PMYF	P1C-4PRS	P1C-4PRC	P1C-4PRF	P14-4PRPZ
Ø 100	P1D-4QMYF	P1C-4PRS	P1C-4PRC	P1C-4PRF	P14-4PRPZ
Ø 125		P1C-4RRS	P1C-4RRC	P1C-4RRF	P14-4RRPZ
Ø 160		KY6863	KY6867	KY1139	
Ø 200		KY6863	KY6867	KY1139	
Ø 250		KY6864	KY6868	KY1140	
Ø 320		KL9132	KL9131	KL9133	

Note: Black anodization available on some mountings.

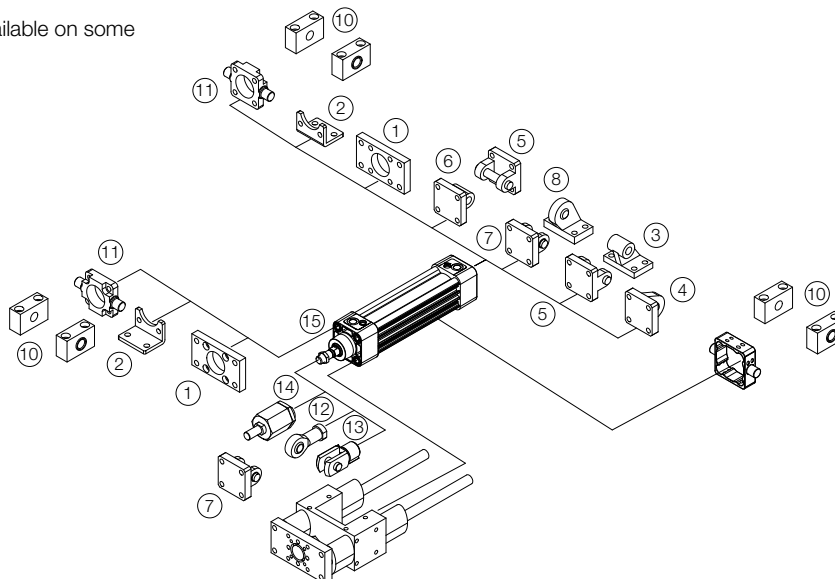

Flange MF1/MF2 ①



Intended for fixed mounting of cylinder. Flange can be fitted to front or rear end cover of cylinder.

Materials
 Flange: Surface-treated steel
 Mounting screws acc. to DIN 6912: Zinc-plated steel 8.8

Supplied complete with mounting screws for attachment to cylinder.

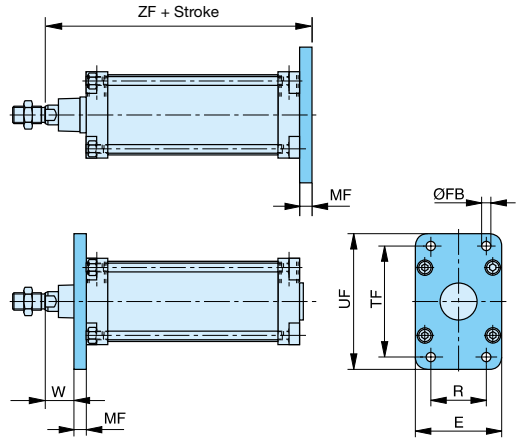

Bore mm	ZF mm	MF mm	W mm	UF mm	E mm	TF mm	R mm	ØFB mm	Weight kg	Order code
32	130,0	10,0	16,0	80,0	45,0	64,0	32,0	7,0	0,23	P1C-4KMB
40	145,0	10,0	20,0	80,0	52,0	72,0	36,0	9,0	0,28	P1C-4LMB
50	155,0	12,0	25,0	80,0	65,0	90,0	45,0	9,0	0,53	P1C-4MMB
63	170,0	12,0	25,0	80,0	75,0	100,0	50,0	9,0	0,71	P1C-4NMB
80	190,0	16,0	30,0	80,0	95,0	126,0	63,0	12,0	1,59	P1C-4PMB
100	205,0	16,0	35,0	80,0	115,0	150,0	75,0	14,0	2,19	P1C-4QMB
125	245,0	20,0	45,0	80,0	140,0	180,0	90,0	16,0	3,78	P1C-4RMB
160	180,0	20,0	60,0	80,0	180,0	230,0	115,0	18,0	7,20	PD23410
200	300,0	25,0	70,0	80,0	220,0	270,0	135,0	22,0	12,20	PD24924
250	330,0	25,0	80,0	80,0	280,0	330,0	165,0	26,0	19,20	PD25761
320	370,0	30,0	90,0	80,0	340,0	400,0	200,0	33,0	38,00	KL9140

Dimensions for cylinders without piston rod protusion or with rod lock unit

Foot brackets MS1 ②



Intended for fixed mounting of cylinder. Foot bracket can be fitted to front and rear end covers of cylinder.

Material:
 Foot bracket: Surface treated steel
 Mounting screws acc. to DIN 912: Zinc-plated steel 8.8

Supplied complete with mounting screws for attachment to cylinder.

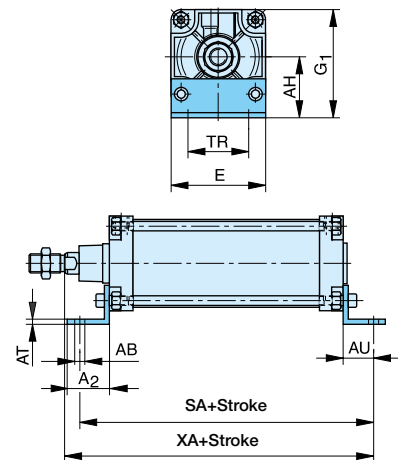

Bore mm	E mm	TR mm	AH mm	G1 mm	AT mm	A2 mm	ØAB mm	SA mm	XA mm	AU mm	Weight kg	Order code
32	45,0	32,0	32,0	56,0	4,5	34,0	7,0	142,0	144,0	24,0	0,06	P1C-4KMF
40	52,0	36,0	36,0	62,8	4,5	36,0	9,0	161,0	163,0	28,0	0,08	P1C-4LMF
50	65,0	45,0	45,0	77,6	5,5	45,0	9,0	170,0	175,0	32,0	0,16	P1C-4MMF
63	75,0	50,0	50,0	87,8	5,5	45,0	9,0	185,0	190,0	32,0	0,25	P1C-4NMF
80	95,0	63,0	63,0	110,5	6,5	55,0	12,0	210,0	215,0	41,0	0,50	P1C-4PMF
100	115,0	75,0	71,0	128,0	6,5	56,0	14,0	220,0	230,0	41,0	0,85	P1C-4QMF
125	140,0	90,0	90,0	159,5	8,0	67,0	16,0	250,0	270,0	45,0	1,48	P1C-4RMF
160	180,0	115,0	115,0	205,0	8,0	80,0	18,0	300,0	320,0	60,0	3,80	PD70512
200	220,0	135,0	135,0	245,0	9,0	100,0	22,0	320,0	345,0	70,0	5,00	PD24792
250	280,0	165,0	165,0	305,0	10,0	110,0	26,0	350,0	380,0	75,0	9,70	PD25758
320	340,0	200,0	200,0	370,0	23,0	125,0	33,0	390,0	470,0	85,0	17,00	KL9139

Weight per item

Dimensions for cylinders without piston rod protusion or with rod lock unit

Pivot bracket with rigid bearing AB7 ③

Intended for flexible mounting of cylinder. The pivot bracket can be combined with clevis bracket MP2.

Material:
Pivot bracket: Aluminium
Bearing: Sintered oil-bronze bushing

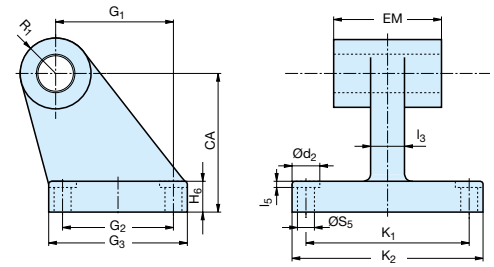

Bore mm	R1 mm	ØCX H7 mm	G1 mm	CA mm	H6 mm	G2 mm	G3 mm	EM mm	l3 mm	Ød2 mm	l5 mm	ØS5 mm	K1 mm	K2 mm	Weight kg	Order code Not anodised	Order code Black anodised
32	10,0	10,0	21,0	32,0	8,0	18,0	31,0	25,5	10,0	-	-	6,6	38,0	51,0	0,06	P1C-4KMDB	P1C-4KMD
40	11,0	12,0	24,0	36,0	10,0	22,0	35,0	27,0	15,0	-	-	6,6	41,0	54,0	0,08	P1C-4LMDB	P1C-4LMD
50	13,0	12,0	33,0	45,0	12,0	30,0	45,0	31,0	16,0	-	-	9,0	50,0	65,0	0,15	P1C-4MMDB	P1C-4MMD
63	15,0	16,0	37,0	50,0	12,0	35,0	50,0	39,0	16,0	-	-	9,0	52,0	67,0	0,20	P1C-4NMDB	P1C-4NMD
80	15,0	16,0	47,0	63,0	14,0	40,0	60,0	49,0	20,0	-	-	11,0	66,0	86,0	0,33	P1C-4PMDB	P1C-4PMD
100	19,0	20,0	55,0	71,0	15,0	50,0	70,0	59,0	20,0	-	-	11,0	76,0	96,0	0,49	P1C-4QMDB	P1C-4QMD
125	22,5	25,0	70,0	90,0	20,0	60,0	90,0	69,0	30,0	-	-	14,0	94,0	124,0	1,02	P1C-4RMDB	P1C-4RMD
160	31,5	30,0	97,0	115,0	25,0	88,0	126,0	90,0	36,0	20,0	4,0	14,0	118,0	156,0	6,50	P1C-4SMDB	-
200	31,5	30,0	105,0	135,0	30,0	90,0	130,0	90,0	40,0	26,0	4,0	18,0	122,0	162,0	8,00	P1C-4TMD	-
250	40,0	40,0	128,0	165,0	35,0	110,0	160,0	110,0	45,0	33,0	4,5	22,0	150,0	200,0	13,50	P1C-4UMDB	-
320	45,0	45,0	150,0	200,0	40,0	122,0	186,0	120,0	55,0	-	-	26,0	170,0	234,0	21,90	P1C-4VMDC	-

Swivel eye bracket MP6 ④

Intended for use together with clevis bracket GA

Material:
Bracket: Aluminium
Swivel bearing acc. to DIN 648K: Hardened steel

Supplied complete with mounting screws for attachment to cylinder.

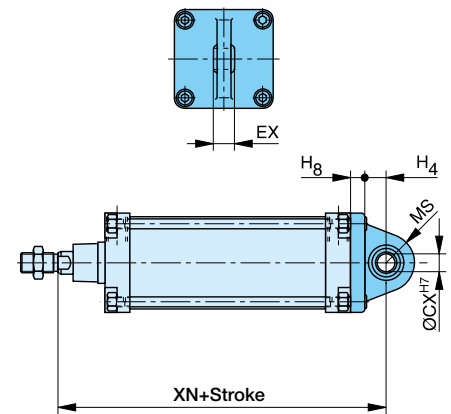

Bore mm	EX mm	XN mm	H8 mm	H4 mm	MS mm	ØCX H7 mm	Weight kg	Order code Not anodised	Order code Black anodised
32	14,0	142,0	10,0	12,0	16,0	10,0	0,10	PD23843	P1C-4KMSA
40	16,0	160,0	10,0	15,0	21,0	12,0	0,11	PD23844	P1C-4LMSA
50	16,0	170,0	11,0	16,0	23,0	12,0	0,20	PD23845	P1C-4MMSA
63	21,0	190,0	11,0	21,0	27,0	16,0	0,27	PD23846	P1C-4NMSA
80	21,0	210,0	15,0	21,0	29,0	16,0	0,52	PD23847	P1C-4PMSA
100	25,0	230,0	16,0	25,0	34,0	20,0	0,72	PD23848	P1C-4QMSA
125	31,0	275,0	20,0	30,0	40,0	25,0	1,53	PD23849	P1C-4RMSA
160	37,0	315,0	20,0	35,0	48,0	30,0	2,60	PD23850	-
200	43,0	335,0	24,0	36,0	47,0	30,0	11,30	PD25766	-
250	49,0	375,0	28,0	42,0	53,0	40,0	19,00	PD25760	-
320	60,0	420,0	30,0	50,0	63,0	45,0	30,30	KL9136	-

Dimensions for cylinders without piston rod protusion or with rod lock unit

Clevis bracket MP2 ⑤



Intended for flexible mounting of cylinder. Clevis bracket MP2 can be combined with clevis bracket MP4.

Material:
 Clevis bracket: Aluminium
 Pin: Surface hardened steel
 Circlips according to DIN 471: Spring steel
 Mounting screws acc. to DIN 912: Zinc-plated steel 8.8

Supplied complete with mounting screws for attachment to cylinder.

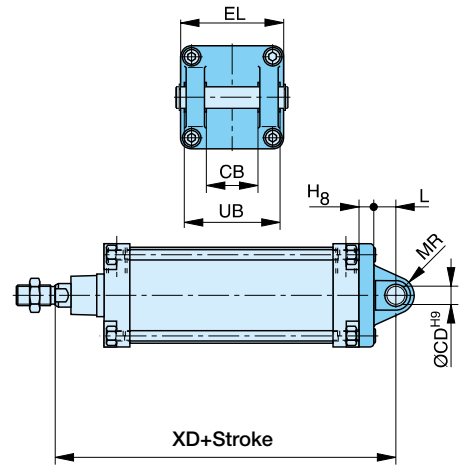

Bore mm	EL mm	XD mm	ØCD H9 mm	CB H14 mm	UB mm	H8 mm	L mm	MR mm	Weight kg	Order code Not anodised	Order code Black anodised
32	53,0	142,0	10,0	26,0	45,0	10,0	12,0	11,0	0,08	P1C-4KMTB	P1C-4KMT
40	60,0	160,0	12,0	28,0	52,0	10,0	15,0	13,0	0,11	P1C-4LMTB	P1C-4LMT
50	68,0	170,0	12,0	32,0	60,0	11,0	16,0	18,0	0,14	P1C-4MMTB	P1C-4MMT
63	78,0	190,0	16,0	40,0	70,0	11,0	21,0	18,0	0,29	P1C-4NMTB	P1C-4NMT
80	98,0	210,0	16,0	50,0	90,0	15,0	21,0	22,0	0,36	P1C-4PMTB	P1C-4PMT
100	118,0	230,0	20,0	60,0	110,0	16,0	25,0	22,0	0,64	P1C-4QMTB	P1C-4QMT
125	139,0	275,0	25,0	70,0	130,0	20,0	30,0	30,0	1,17	P1C-4RMTB	P1C-4RMT
160	172,0	315,0	30,0	90,0	170,0	20,0	35,0	30,0	2,60	P1C-4SMTB	-
200	172,0	335,0	30,0	90,0	170,0	25,0	35,0	31,0	4,10	P1C-4TMTB	-
250	280,0	375,0	40,0	110,0	200,0	25,0	45,0	41,0	7,10	P1C-4UMTB	-
320	340,0	420,0	45,0	120,0	220,0	30,0	50,0	54,0	31,0	P1C-4VMTB	-

Dimensions for cylinders without piston rod protusion or with rod lock unit

Clevis bracket MP4 ⑥



Intended for flexible mounting of cylinder. Clevis bracket MP4 can be combined with clevis bracket MP2.

Material:
 Clevis bracket: Aluminium
 Mounting screws acc. to DIN 912: Zinc-plated steel 8.8

Supplied complete with mounting screws for attachment to cylinder.

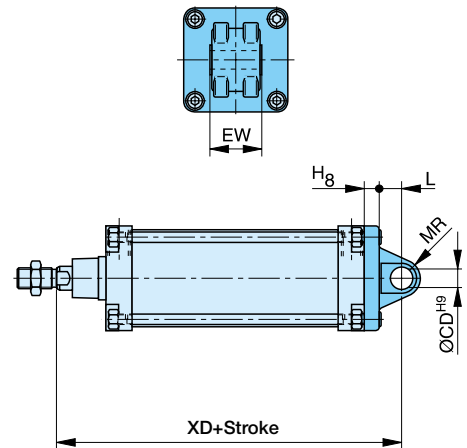

Bore mm	EW mm	XD mm	H8 mm	L mm	MR mm	ØCD mm	Weight kg	Order code Not anodised	Order code Black anodised
32	26,0	142,0	10,0	12,0	11,0	10,0	0,09	PD23412	P1C-4KME
40	28,0	160,0	10,0	15,0	13,0	12,0	0,13	PD23413	P1C-4LME
50	32,0	170,0	11,0	16,0	18,0	12,0	0,17	PD23414	P1C-4MME
63	40,0	190,0	11,0	21,0	18,0	16,0	0,36	PD23415	P1C-4NME
80	50,0	210,0	15,0	21,0	22,0	16,0	0,58	PD23416	P1C-4PME
100	60,0	230,0	16,0	25,0	22,0	20,0	0,89	PD23417	P1C-4QME
125	70,0	275,0	20,0	30,0	30,0	25,0	1,75	PD23418	P1C-4RME
160	90,0	315,0	20,0	35,0	30,0	30,0	2,70	PD22628	-
200	90,0	335,0	25,0	35,0	31,0	30,0	4,20	PD24999	-
250	110,0	375,0	25,0	45,0	41,0	40,0	15,70	PD25759	-
320	120,0	420,0	30,0	50,0	46,0	45,0	33,00	KL9135	-

Dimensions for cylinders without piston rod protusion or with rod lock unit

Clevis bracket AB6 ⑦



Intended for flexible mounting of cylinder. Clevis bracket GA can be combined with pivot bracket with swivel bearing, swivel eye bracket and swivel rod eye.

Material:
 Clevis bracket: Aluminium
 Pin: Surface hardened steel
 Locking pin: Spring steel
 Circlips according to DIN 471: Spring steel
 Mounting screws acc. to DIN 912: Zinc-plated steel 8.8

Supplied complete with mounting screws for attachment to cylinder.

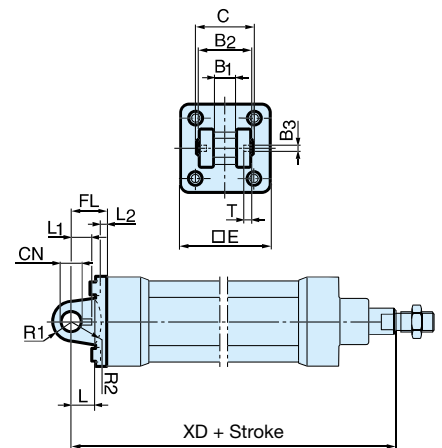

Bore mm	C mm	B2 mm	B1 mm	B3 mm	T mm	E mm	ØCN mm	L1 mm	FL mm	L2 mm	R1 mm	R2 mm	L mm	Weight kg	Order code Not anodised	Order code Black anodised
32	41	34	14	3,3	3	45	10	11,5	22	5,5	11	17	12	0,09	P1C-4KMCB	P1C-4KMCA
40	48	40	16	4,3	4	55	12	12,0	25	5,5	13	20	15	0,13	P1C-4LMCB	P1C-4LMCA
50	54	45	21	4,3	4	65	16	14,0	27	6,5	18	22	17	0,17	P1C-4MMCB	P1C-4MMCA
63	60	51	21	4,3	4	75	16	14,0	32	6,5	18	25	20	0,36	P1C-4NMCB	P1C-4NMCA
80	75	65	25	4,3	4	95	20	16,0	36	10,0	22	30	20	0,58	P1C-4PMCB	P1C-4PMCA
100	85	75	25	4,3	4	115	20	16,0	41	10,0	22	32	25	0,89	P1C-4QMCB	P1C-4QMCA
125	110	97	37	6,3	6	140	30	24,0	50	10,0	30	42	30	1,75	P1C-4RMCB	P1C-4RMCA

Dimensions for cylinders without piston rod protusion or with rod lock unit

Pivot bracket with swivel bearing CS7 ⑧



Intended for use together with clevis bracket GA.

Material:
 Pivot bracket: Surface-treated steel
 Swivel bearing acc. to DIN 648K: Hardened steel

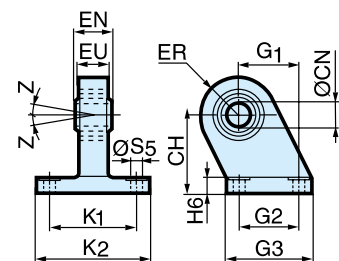

Bore mm	EN mm	EU mm	Z mm	ØS5 mm	K1 mm	K2 mm	ER mm	G1 mm	ØCN mm	CH mm	H6 mm	G2 mm	G3 mm	Weight kg	Order code	Order code Black steel
32	14	10,5	4°	6,6	38	51	16	21	10	32	10	18	31	0,18	KC5130	P1C-4KMA
40	16	12,0	4°	6,6	41	54	18	24	12	36	10	22	35	0,25	KC5131	P1C-4LMA
50	21	15,0	4°	9,0	50	65	21	33	16	45	12	30	45	0,47	KC5132	P1C-4MMA
63	21	15,0	4°	9,0	52	67	23	37	16	50	12	35	50	0,57	KC5133	P1C-4NMA
80	25	18,0	4°	11,0	66	86	28	47	20	63	14	40	60	1,05	KC5134	P1C-4PMA
100	25	18,0	4°	11,0	76	96	30	55	20	71	15	50	70	1,42	KC5135	P1C-4QMA
125	37	25,0	4°	14,0	94	124	40	70	30	90	20	60	90	3,10	KC5136	P1C-4RMA

3 and 4 positions flange JP1



Mounting kit for back to back mounted cylinders, 3 and 4 positions cylinders.

Material:
Mounting: Aluminium
Mounting screws: Zinc-plated steel 8.8

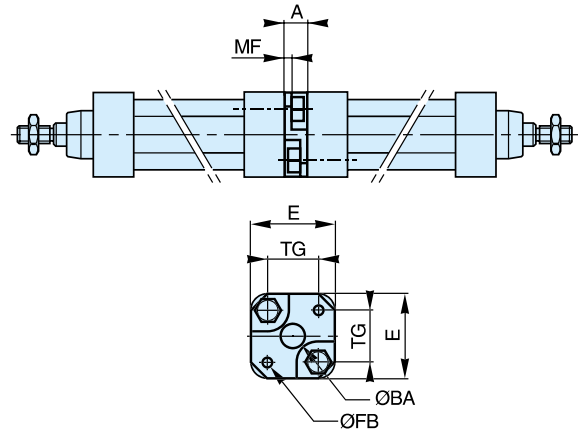

Bore mm	E mm	TG mm	ØFB mm	MF mm	A mm	ØBA mm	Weight kg	Order code
32	50	32,5	6,5	5	16	30	0,09	P1E-6KB0
40	60	38,0	6,5	5	16	35	0,13	P1E-6LB0
50	66	46,5	8,5	6	20	40	0,17	P1E-6MB0
63	80	56,5	8,5	6	20	45	0,37	P1E-6NB0
80	100	72,0	10,5	8	25	45	0,46	P1E-6PB0
100	118	89,0	10,5	8	25	55	0,83	P1E-6QB0

Pivot brackets AT4 for MT* mounting trunnion



Intended for use together with intermediate trunnion MT4 or MT5 / MT6.

Material:
Pivot bracket:
Ø32-125 mm – Aluminium
Ø160-250 mm – Anodised aluminium
Ø 320 mm – steel

Bearing acc. to DIN 1850 C

Supplied in pairs.

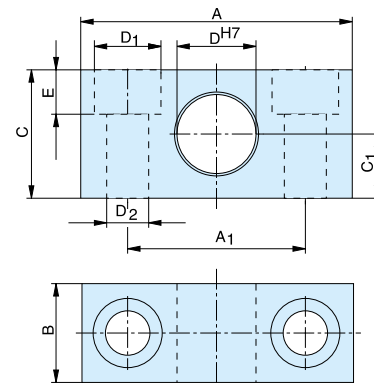

Bore mm	A mm	A1 mm	B mm	C mm	C1 mm	ØD H7 mm	ØD1 mm	ØD2 mm	E mm	Weight kg	Order code
32	55	36	20	26	13	12	13,5	8,4	9,0	0,06	PD23381
40	55	36	20	26	13	16	13,5	8,4	9,0	0,06	PD23382
50	55	36	20	26	13	16	13,5	8,4	9,0	0,06	PD23382
63	65	42	25	30	15	20	16,5	10,5	11,0	0,10	PD23383
80	65	42	25	30	15	20	16,5	10,5	11,0	0,10	PD23383
100	75	50	28	40	20	25	19,0	13,0	13,0	0,18	PD23384
125	75	50	28	40	20	25	19,0	13,0	13,0	0,18	PD23384
160	92	60	35	60	30	32	26,0	18,0	17,0	0,35	PD24425
200	92	60	35	60	30	32	26,0	18,0	17,0	0,35	PD24425
250	140	90	40	70	35	40	33,0	22,0	21,5	0,50	PD25763
320	150	100	60	80	40	50	40,0	26,0	25,5	6,70	KL9130

**Intermediate trunnion
MT4**



The trunnion is MT4 for P1D-T factory-fitted in the centre of the cylinder or at an optional location specified by the XV-measure - Combined with pivot brackets AT4.

Material:
Trunnion: Zinc plated steel
Trunnion centred
The central trunnion for the P1D-T is ordered with letter D in position 17 (no dimension specified in positions 18-20).
e.g. P1D-T160MS-0500NDNNN
Trunnion with optional location

The trunnion for the P1D-T is ordered with letter G in position 17 and desired XV-measure (3-digit measure in mm) in positions 18-20. e.g. P1D-T160MS-0500NG300

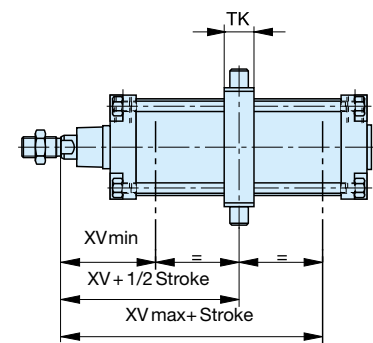
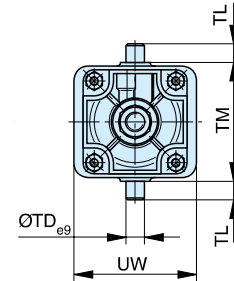
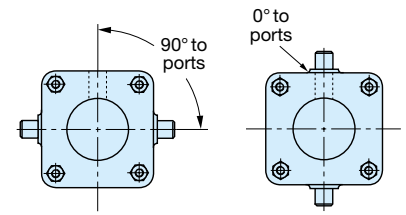

Bore mm	TK mm	TL h14 mm	TM h14 mm	ØTD e9 mm	XV _{min} mm	XV mm	XV _{max} mm	Weight kg
32	15	12	50	12	62,0	73,0	84,0	0,13
40	20	16	63	16	73,0	82,5	92,0	0,31
50	20	16	75	16	80,5	90,0	99,5	0,37
63	25	20	90	20	89,0	97,5	106,0	0,69
80	25	20	110	20	98,0	110,0	122,0	0,89
100	30	25	132	25	110,5	120,0	129,5	1,58
125	32	25	180	25	132,0	145,0	158,0	2,60
160	45	32	200	32	150,0	170,0	190,0	6,10
200	50	32	250	32	165,0	185,0	205,0	8,10
250	55	40	320	40	195,0	205,0	210,0	14,8
320	65	50	400	50	210,0	230,0	250,0	16,0

Important: If the cylinder is ordered with a piston rod protusion (WH dimension), please add this extra length to XVmin, XV and XVmax.

**Flange trunnion 11
MT5/MT6**



Intended for articulated mounting of cylinder. This trunnion can be flange mounted on the front or rear end cover of all P1D cylinders.
Individual trunnions have order code as shown to the right.

Material:
Trunnion: zinc plated steel
Screws: zinc plated steel, 8.8

Delivered complete with mounting screws for attachment to the cylinder

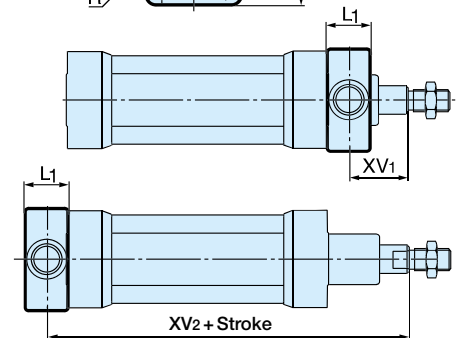
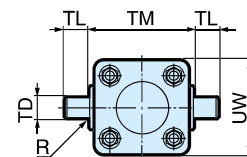

Bore mm	TM h14 mm	TL h14 mm	ØTD e9 mm	R mm	UW mm	L1 mm	XV ₁ mm	XV ₂ mm	Weight kg	Order code
32	50	12	12	1,0	46	14	19,5	127,0	0,17	P1D-4KMYF
40	63	16	16	1,6	59	19	21,0	144,0	0,43	P1D-4LMYF
50	75	16	16	1,6	69	19	28,0	152,5	0,55	P1D-4MMYF
63	90	20	20	1,6	84	24	25,5	170,0	1,10	P1D-4NMYF
80	110	20	20	1,6	102	24	34,5	186,0	1,66	P1D-4PMYF
100	132	25	25	2,0	125	29	37,0	203,5	3,00	P1D-4QMYF

Dimensions for cylinders without piston rod protusion or with rod lock unit

Swivel rod eye AP6 12



Swivel rod eye for articulated mounting of cylinder. Swivel rod eye can be combined with clevis bracket GA. Maintenance-free.

Material:
Swivel rod eye: Zinc-plated steel
Swivel bearing according to DIN 648K: Hardened steel

Swivel rod eye: Stainless steel
Swivel bearing according to DIN 648K: Hardened steel

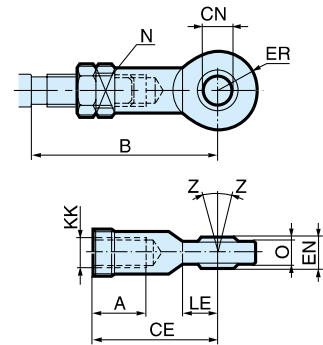

According to ISO 8139

Bore mm	A mm	B _{min} mm	B _{max} mm	CE mm	ØCN H9 mm	EN h12 mm	ER mm	KK mm	LE _{min} mm	N mm	O mm	Z mm	Weight kg	Order code	Order code Stainless steel
32	20	48,0	55	43	10	14	14	M10x1,25	15	17	10,5	12°	0,08	P1C-4KRS	P1S-4JRT
40	22	56,0	62	50	12	16	16	M12x1,25	17	19	12,0	12°	0,12	P1C-4LRS	P1S-4LRT
50	28	72,0	80	64	16	21	21	M16x1,5	22	22	15,0	15°	0,25	P1C-4MRS	P1S-4MRT
63	28	72,0	80	64	16	21	21	M16x1,5	22	22	15,0	15°	0,25	P1C-4MRS	P1S-4MRT
80	33	87,0	97	77	20	25	25	M20x1,5	26	32	18,0	15°	0,46	P1C-4PRS	P1S-4PRT
100	33	87,0	97	77	20	25	25	M20x1,5	26	32	18,0	15°	0,46	P1C-4PRS	P1S-4PRT
125	51	123,5	137	110	30	37	35	M27x2	36	41	25,0	15°	1,28	P1C-4RRS	P1S-4RRT
160	56			125	35	43	40	M36x2	41	50	28,0		1,60	KY6863	-
200	56			125	35	43	40	M36x2	41	50	28,0		1,60	KY6863	-
250	60			142	40	49	45	M42x2	46	55	33,0		3,50	KY6864	-
320	65			160	50	60	58	M48x2	59	65	45,0		5,20	KY9132	-

Clevis AP2 13



Clevis for articulated mounting of cylinder.

Material:
Clevis, clip: Galvanized steel
Pin: Hardened steel

Clevis, clip: Stainless steel
Pin: Stainless steel

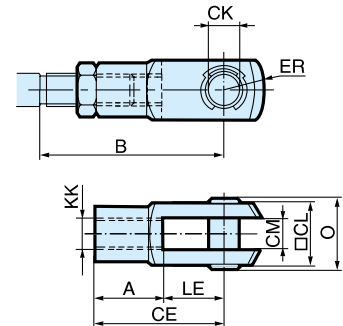

According to ISO 8140

Bore mm	A mm	B _{min} mm	B _{max} mm	CE mm	CK h11/e9 mm	CL mm	CM mm	ER mm	KK mm	LE mm	O mm	Weight kg	Order code	Order code Stainless steel
32	20	45,0	52	40	10	20	10	16	M10x1,25	20	28,0	0,09	P1C-4KRC	P1S-4JRD
40	24	54,0	60	48	12	24	12	19	M12x1,25	24	32,0	0,15	P1C-4LRC	P1S-4LRD
50	32	72,0	80	64	16	32	16	25	M16x1,5	32	41,5	0,35	P1C-4MRC	P1S-4MRD
63	32	72,0	80	64	16	32	16	25	M16x1,5	32	41,5	0,35	P1C-4MRC	P1S-4MRD
80	40	90,0	100	80	20	40	20	32	M20x1,5	40	50,0	0,75	P1C-4PRC	P1S-4PRD
100	40	90,0	100	80	20	40	20	32	M20x1,5	40	50,0	0,75	P1C-4PRC	P1S-4PRD
125	56	123,5	137	110	30	55	30	45	M27x2	54	72,0	2,10	P1C-4RRC	P1S-4RRD
160	72			144	35	70	36		M36x2	72		2,90	KY6867	-
200	72			144	35	70	36		M36x2	72		2,90	KY6867	-
250	84			168	40	85	40		M42x2	84		6,00	KY6868	-
320	96			192	50	90	50		M48x2	96		7,90	KY9131	-

Flexo coupling PM5 ¹⁴



Flexo coupling for articulated mounting of piston rod. Flexo fitting is intended to take up axial angle errors within a range of ±4°.

Material
Flexo coupling, nut: Zinc-plated steel

Supplied complete with galvanized adjustment nut.

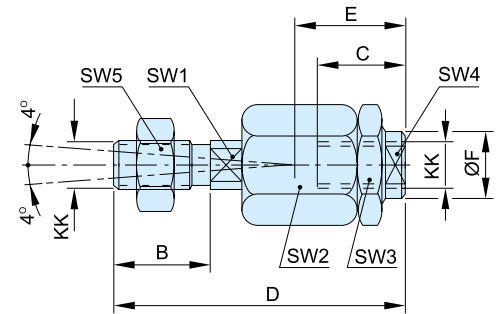

Bore mm	KK mm	B mm	C mm	D mm	E mm	ØF mm	SW1 mm	SW2 mm	SW3 mm	SW4 mm	SW5 mm	Weight kg	Order code
32	M10x1,25	20	23	73	31	21,0	12	30	30	19	17	0,21	P1C-4KRF
40	M12x1,25	24	23	77	31	21,0	12	30	30	19	19	0,22	P1C-4LRF
50	M16x1,5	32	32	108	45	33,5	19	41	41	30	24	0,67	P1C-4MRF
63	M16x1,5	32	32	108	45	33,5	19	41	41	30	24	0,67	P1C-4MRF
80	M20x1,5	40	42	122	56	33,5	19	41	41	30	30	0,72	P1C-4PRF
100	M20x1,5	40	42	122	56	33,5	19	41	41	30	30	0,72	P1C-4PRF
125	M27x2	54	48	147	51	39,0	24	55	55	32	41	1,80	P1C-4RRF
160	M36x2	72	50	241	110	56,0	36	75	75	50	55	5,10	KY1139
200	M36x2	72	50	241	110	56,0	36	75	75	50	55	5,10	KY1139
250	M42x2	82	88	271	120	-	36	80	80	60	65	7,90	KY1140
320	M48x2	82	88	271	120	-	42	80	80	60	75	7,90	KY9133

Nut MR9 ¹⁵



Intended for fixed mounting of accessories to the piston rod. Material: Zinc-plated steel

All P1D cylinders are delivered with a zinc-plated steel piston rod nut, except P1D Ultra Clean, which is delivered with a stainless steel piston rod nut instead.

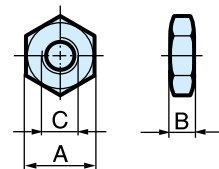

Stainless steel nut MR9



Intended for fixed mounting of accessories to the piston rod.

Material: Stainless steel A2

All P1D cylinders are delivered with a zinc-plated steel piston rod nut, except P1D-C delivered with a stainless steel piston rod nut instead.

Acid-proof nut MR9



Intended for fixed mounting of accessories to the piston rod.

Material: Acid-proof steel A4

Cylinders with acid-proof piston rod are supplied with nut of acid-proof steel

According to DIN 439 B

Bore mm	A mm	B mm	C mm	Weight kg	Nut	Stainless steel nut	Acid-proof nut
					Order code	Order code	Order code
32	17	5,0	M10x1,25	0,007	P14-4KRPZ	P14-4KRPS	P14-4KRPX
40	19	6,0	M12x1,25	0,010	P14-4LRPZ	P14-4LRPS	P14-4LRPX
50	24	8,0	M16x1,5	0,021	P14-4MRPZ	P14-4MRPS	P14-4MRPX
63	24	8,0	M16x1,5	0,021	P14-4MRPZ	P14-4MRPS	P14-4MRPX
80	30	10,0	M20x1,5	0,040	P14-4PRPZ	P14-4PRPS	P14-4PRPX
100	30	10,0	M20x1,5	0,040	P14-4PRPZ	P14-4PRPS	P14-4PRPX
125	41	13,5	M27x2	0,100	P14-4RRPZ	P14-4RRPS	P14-4RRPX

* Supplied as pack of 10 off

** Weight per item

Type	Description	Cyl. bore Ø mm	Weight kg	Order code
Stainless steel screw set for MP2, MP4, MS1 and AB6 	Set of stainless steel screws for fitting clevis brackets MP2, MP4 and GA onto the cylinder. The screws have an internal hexagonal head and are used in special environments, e.g. the food industry, or where there are extra demands for protection against corrosion. Material: According to DIN 912, Stainless steel, A2 4 pcs per pack.	32	0,02	9301054321
		40	0,02	9301054321
		50	0,05	9301054322
		63	0,05	9301054322
		80	0,09	9301054323
		100	0,09	9301054323
		125	0,15	9301054324

Stainless steel screw set for MF1/MF2 	Set of stainless steel screws for fitting flanges MF1/MF2 onto the cylinder. The screws have an internal hexagonal head and are used in special environments, e.g. the food industry, or where there are extra demands for protection against corrosion. Material: According to DIN 6912, Stainless steel, A2 4 pcs per pack	32	0,02	9301054331
		40	0,02	9301054331
		50	0,04	9301054332
		63	0,04	9301054332
		80	0,07	9301054333
		100	0,07	9301054333
		125	0,12	9301054334

Stainless steel pin AA6 set for AB6 mounting

Materials

Pin: stainless steel
 Locking pin: stainless steel
 Circlips according to DIN 471: stainless steel

Cyl. Bore Ø mm	Weight kg	Order code
32	0.05	9301054311
40	0.06	9301054312
50	0.07	9301054313
63	0.07	9301054314
80	0.17	9301054315
100	0.31	9301054316
125	0.54	9301054317

Stainless steel pin AA4 set for MP2 mounting

Materials

Pin: stainless steel
 Locking pin: stainless steel
 Circlips according to DIN 471: stainless steel

Cyl. Bore Ø mm	Weight kg	Order code
32	0.07	on request
40	0.08	on request
50	0.09	on request
63	0.09	on request
80	0.19	on request
100	0.33	on request
125	0.56	on request

Drop-in sensors

Choose between electronic or reed sensors and several cable lengths and 8 mm and M12 connectors.

The same standard sensors are used for all P1D versions.



Electronic sensors

The electronic sensors are "Solid State", i.e. they have no moving parts at all. They are provided with short-circuit protection and transient protection as standard. The built-in electronics make the sensors suitable for applications with high on and off switching frequency, and where very long service life is required.

Technical data

Design	GMR (Giant Magnetic Resistance) magneto-resistive function
Installation	From side, down into the sensor groove, so-called drop-in
Outputs	PNP, normally open (also available in NPN design, normally closed, on request)
Voltage range	10-30 VDC 10-18 V DC, ATEX sensor
Ripple	max 10%
Voltage drop	max 2,5 V
Load current	max 100 mA
Internal consumption	max 10 mA
Actuating distance	min 9 mm
Hysteresis	max 1,5 mm
Repeatability accuracy	max 0,2 mm
On/off switching frequency	max 5 kHz
On switching time	max 2 ms
Off switching time	max 2 ms
Encapsulation	IP 67 (EN 60529)
Temperature range	-25 °C to +75 °C -20 °C to +45 °C, ATEX sensor
Indication	LED, yellow
Material housing	PA 12
Material screw	Stainless steel
Cable	PVC or PUR 3x0.25 mm ² see order code respectively

Reed sensors

The sensors are based on proven reed switches, which offer reliable function in many applications. Simple installation, a protected position on the cylinder and clear LED indication are important advantages of this range of sensors.

Technical data

Design	Reed element
Mounting	From side, down into the sensor groove, so-called drop-in
Output	Normally open , or normally closed
Voltage range	10-30 V AC/DC or 10-120 V AC/DC 24-230 V AC/DC
Load current	max 500 mA for 10-30 V or max 100 mA for 10-120 V max 30 mA for 24-230 V
Breaking power (resistive)	max 6 W/VA
Actuating distance	min 9 mm
Hysteresis	max 1,5 mm
Repeatability accuracy	0,2 mm
On/off switching frequency	max 400 Hz
On switching time	max 1,5 ms
Off switching time	max 0,5 ms
Encapsulation	IP 67 (EN 60529)
Temperature range	-25 °C to +75 °C
Indication	LED, yellow
Material housing	PA12
Material screw	Stainless steel
Cable	PVC or PUR 3x0.14 mm ² see order code respectively

Electronic sensors

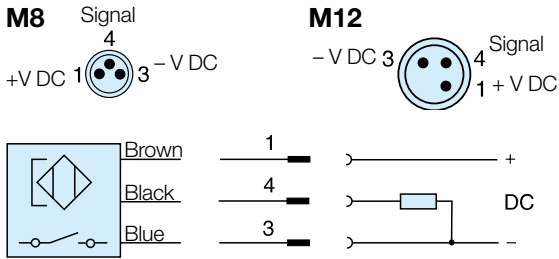

Reed sensors

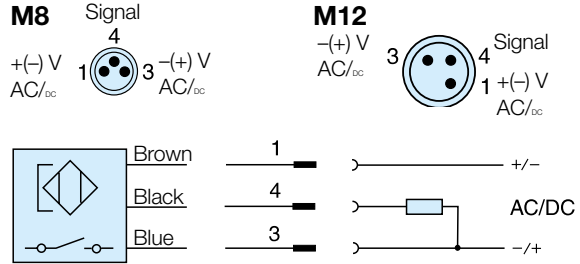

P8S-GCFPX

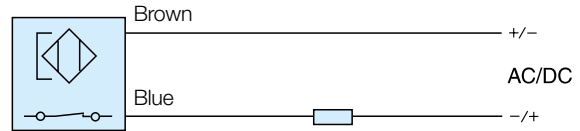

P8S-GRFLX / P8S-GRFLX2

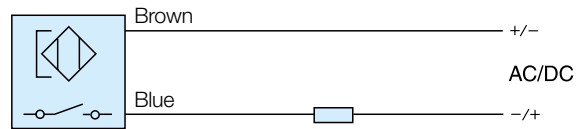

Dimensions

Sensors

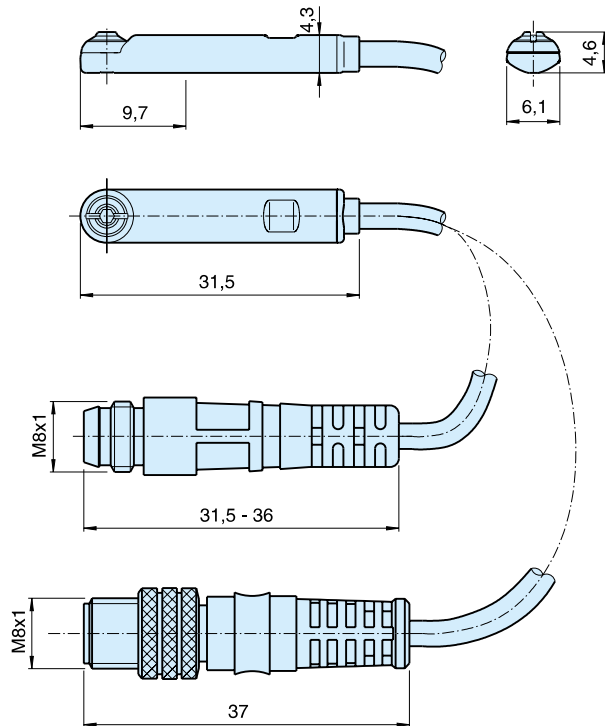

Sensor mounting - P1D-T 32 - 125mm

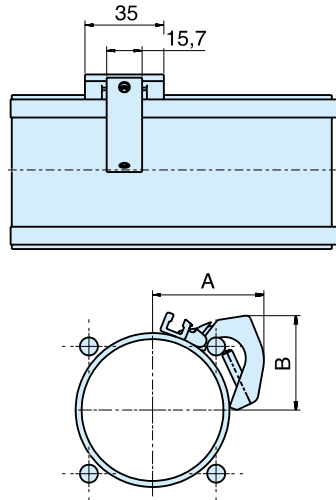

Cyl. bore mm	A mm	B mm
32	35	26
40	39	30
50	44	30
63	50	42
80	54	52
100	62	60
125	74	69

Order code
P8S-TMA0X

Sensor mounting - P1D-T 160 - 320mm

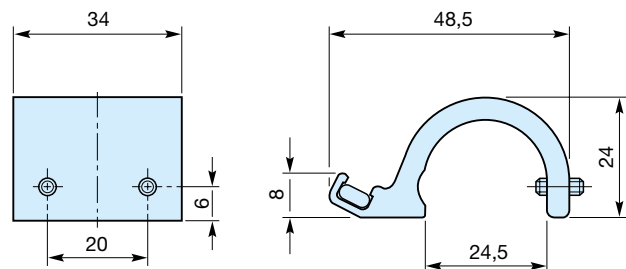

Order code
PD48956

Ordering data

Output/function	Cable/connector	Weight kg	Order code
Electronic sensors , 10-30 V DC			
PNP type, normally open	0,27 m PUR-cable and 8 mm snap-in male connector	0,007	P8S-GPSHX
PNP type, normally open	0,27 m PUR-cable and M12 screw male connector	0,015	P8S-GPMHX
PNP type, normally open	3 m PVC-cable without connector	0,030	P8S-GPFLX
PNP type, normally open	10 m PVC-cable without connector	0,110	P8S-GPFTX
Reed sensors , 10-30 V AC/DC			
Normally open	0,27 m PUR-cable and 8 mm snap-in male connector	0,007	P8S-GSSHX
Normally open	0,27 m PUR-cable and M12 screw male connector	0,015	P8S-GSMHX
Normally open	3 m PVC-cable without connector	0,030	P8S-GSFLX
Normally open	10 m PVC-cable without connector	0,110	P8S-GSFTX
Normally closed	5m PVC-cable without connector ²⁾	0,050	P8S-GCFPX
Reed sensors, 10-120 V AC/DC			
Normally open	3 m PVC-cable without connector	0,030	P8S-GRFLX
Reed sensorer, 24-230 V AC/DC			
Normally open	3 m PVC-cable without connector	0,030	P8S-GRFLX2

2) Without LED

Adapter for tie-rod design

Description	Weight kg	Order code
Double jointed adapter for cylinder P1D-T cylinder bore Ø32 to Ø125 mm	0,07	P8S-TMA0X
Double jointed adapter for cylinder P1D-T cylinder bore Ø160 to Ø320 mm	0,07	PD48956



Connecting cables with one connector

The cables have an integral snap-in female connector.



Type of cable	Cable/connector	Weight kg	Order code
Cables for sensors, complete with one female connector			
Cable, Flex PVC	3 m, 8 mm Snap-in connector	0,07	9126344341
Cable, Flex PVC	10 m, 8 mm Snap-in connector	0,21	9126344342
Cable, Polyurethane	3 m, 8 mm Snap-in connector	0,01	9126344345
Cable, Polyurethane	10 m, 8 mm Snap-in connector	0,20	9126344346
Cable, Polyurethane	5 m, M12 screw connector	0,07	9126344348
Cable, Polyurethane	10 m, M12 screw connector	0,20	9126344349

Male connectors for connecting cables

Cable connectors for producing your own connecting cables. The connectors can be quickly attached to the cable without special tools. Only the outer sheath of the cable is removed. The connectors are available for M8 and M12 screw connectors and meet protection class IP 65.



Technical data

Operating voltage	max. 32 V AC/DC	Connector	Weight kg	Order code
Operating current per contact	max. 4 A	M8 screw connector	0,017	P8CS0803J
Connection cross section	0,25...0,5mm ² (conductor diameter min 0.1mm)	M12 screw connector	0,022	P8CS1204J
Protection	IP65 and IP67 when plugged and screwed down (EN 60529)			
Temperature range	-25...+85 °C			

Pneumatic cylinder sensor for P1D-T

An ideal solution where a direct pneumatic signal is wanted from a cylinder sensor to a pneumatic control system, for example. This could be a machine or device in which only compressed air is available, and an electricity supply to normal cylinder sensors would involve serious problems or considerable expense.

Function:

Non-contacting sensing of a pneumatic cylinder, triggering an output signal (conn. 2) from the integrated 3/2 NC valve, which is activated by a magnetic field or iron core and has a return spring.

If more than one sensor is used with a cylinder there must be a distance of at least 20 mm between sensors to prevent them influencing each other.

To avoid interference, there must be a minimum spacing of 15 mm to steel details.

The outlet (conn. 3) must not be blocked or restricted as this can impair the function of the sensor.

The sensor is fastened to the cylinder using the special sensor fixing.

Technical data:

- Working pressure: min 2 to max 6 bar
- Temperature: -15 to +60 °C
- Air quality: 3.4.3 to ISO 8573-1 (must be oil free)
- Function: 3/2 NC valve
- Flow: 40 NI per minute
- Connection: for plastic pipe with 2,5-3 mm internal diameter
- Activation distance: for magnet: min 9 mm
- Activation distance: for Fe: approx. 2 mm
- Repetition accuracy: +/- 0.2 mm
- Cylinder velocity: max 1 m/s (depends on magnetic field, interference from steel in environment, signal length requirement from control system....)
- Distance between sensors: min 20 mm
- Distance from sensor to steel details: min 15 mm
- Fixing: with sensor fixing or with an M4 thread in case
- Sensing: non-contacting (also through a wall of non-magnetic material)

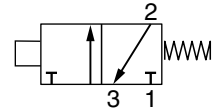

Description	Weight kg	Order code
Pneumatic sensor	0,02	P8S-A34X
Fixing for P1D-T cylinder bore Ø32 to Ø125 mm	0,01	P8S-AMA1

Cylinder fixing - P1D-T 32 - 125mm

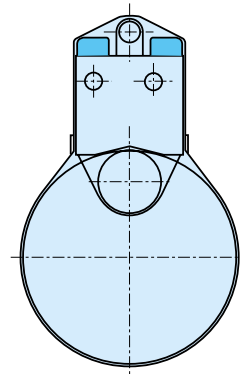

Dimensions (mm)

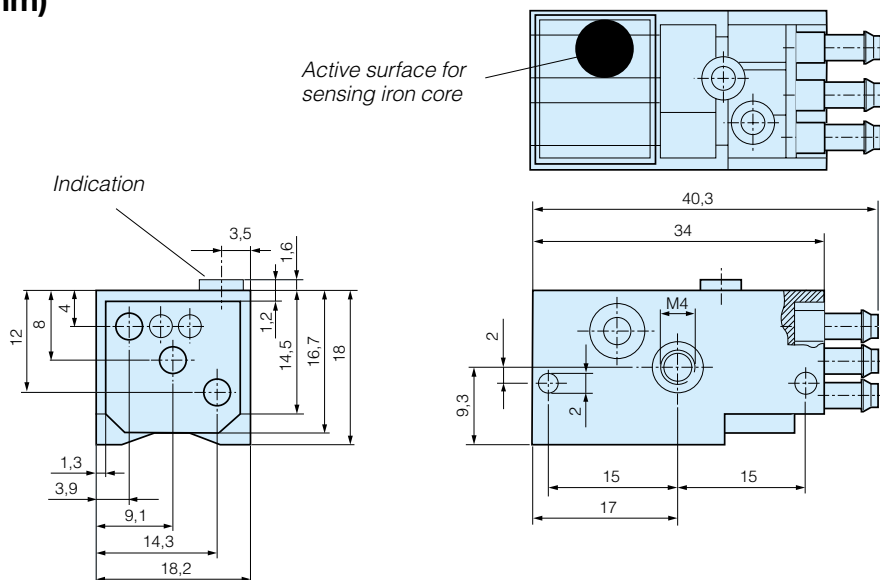

P1D Seal kits

Complete seal kits consisting of:
 Piston seals
 Cushioning seals
 Piston rod bearing
 Combined piston rod seal and scraper ring
 O-rings



Cyl.bore mm	P1D-T cylinder version			
	Standard	Standard temperature with FPM scraper ring	Standard temperature Dry piston rod with HDPE scraper ring	Through rod Standard temperature
32	P1D-6KRN	P1D-6KRV	P1D-6KRD	P1D-6KRNF
40	P1D-6LRN	P1D-6LRV	P1D-6LRD	P1D-6LRNF
50	P1D-6MRN	P1D-6MRV	P1D-6MRD	P1D-6MRNF
63	P1D-6NRN	P1D-6NRV	P1D-6NRD	P1D-6NRNF
80	P1D-6PRN	P1D-6PRV	P1D-6PRD	P1D-6PRNF
100	P1D-6QRN	P1D-6QRV	P1D-6QRD	P1D-6QRNF
125	P1D-6RRN	P1D-6RRV	P1D-6RRD	P1D-6RRNF

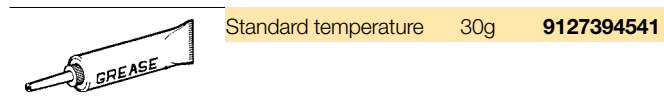

Seal kit for bores Ø32 - Ø125 mm

- = Included in seal kit
- = Screwdriver head
- = Insexgrepp

- = Tightening torque
- = Lubricated with grease
- = Locking fluid

*Loctite 270 or
 Loctite 2701 locking
 fluid must be used*

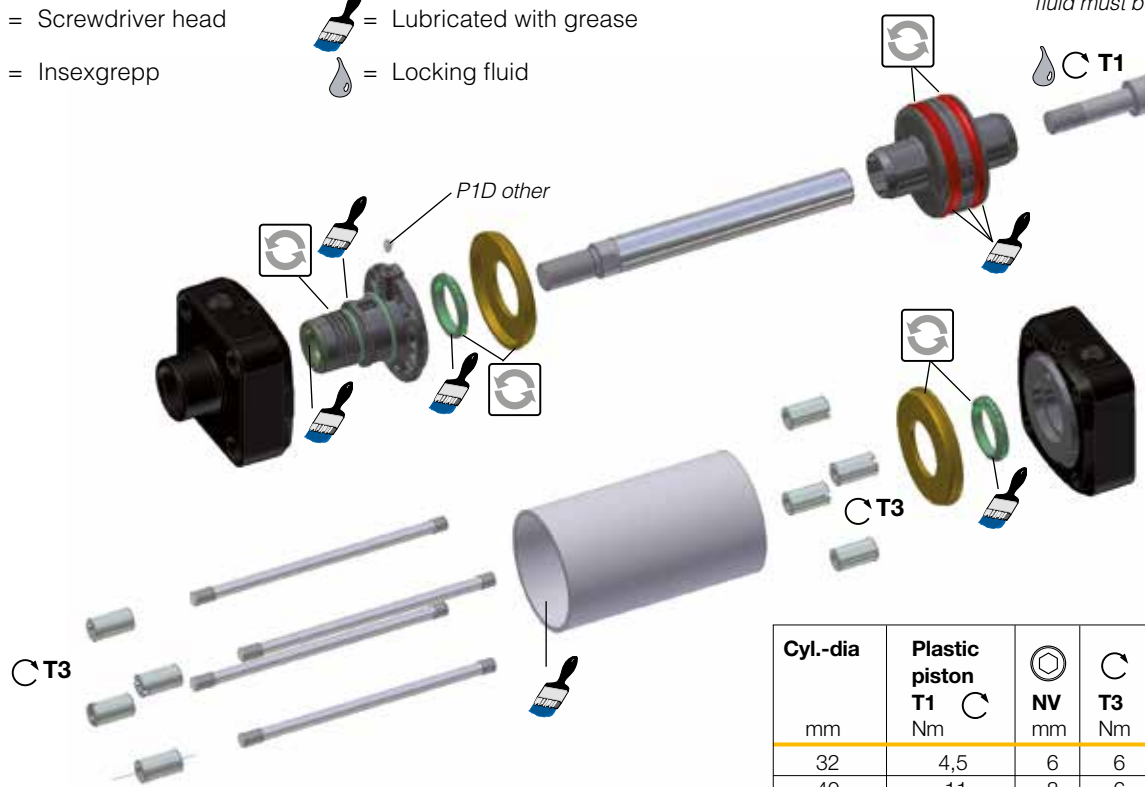

Cyl.-dia mm	Plastic piston T1 Nm	 NV mm	 T3 Nm	 NV mm	 NV mm
32	4,5	6	6	6	
40	11	8	6	6	
50	20	10	11	8	
63	20	10	11	8	
80	40	14	20		3x16
100	120	14	20		3x16
125	120	14	40		4x18

Seal kits

Complete seal kits consisting of:

- Piston seals
- Cushioning seals
- Piston rod seal
- O-rings
- Scraper ring



Cyl.bore mm	P1D cylinder version			
	High temp.	Low temp.	Metal scraper	Hydraulic version
32	P1D-6KRFX	P1D-6KRLX	P1D-6KRQX	P1D-6KRHX
40	P1D-6LRF	P1D-6LRL	P1D-6LRQX	P1D-6LRH
50	P1D-6MRFX	P1D-6MRLX	P1D-6MRQX	P1D-6MRHX
63	P1D-6NRF	P1D-6NRL	P1D-6NRQX	P1D-6NRH
80	P1D-6PRF	P1D-6PRL	P1D-6PRQX	P1D-6PRH
100	P1D-6QRF	P1D-6QRL	P1D-6QRQX	P1D-6QRH
125	P1D-6RRF	P1D-6RRL	P1D-6RRQX	P1D-6RRH

	Standard temperature	30g	9127394541
	High temperature	30g	9127394521
	Low temperature	30g	9127394541

Seal kit for bores Ø32 - Ø125 mm

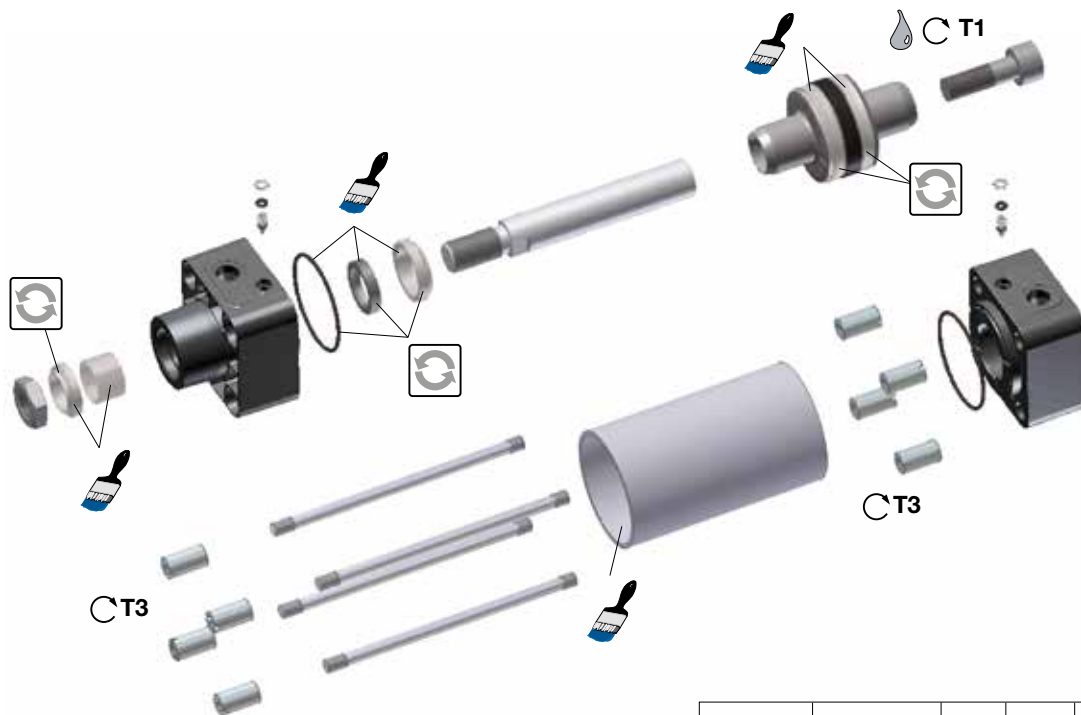

= Included in seal kit

Lubricated with grease

= Socket head

Locking fluid

= Tightening torque

Loctite 270 or Loctite 2701 locking fluid must be used

Cyl.-dia mm	Aluminium piston T1 Nm	AF mm	T3 Nm	NV mm	NV mm
32	15	6	6	6	
40	30	8	6	6	
50	40	10	11	8	
63	40	10	11	8	
80	120	14	20		3x16
100	120	14	20		3x16
125	120	14	40		4x18

Seal Kits

Complete seal kits consisting of:
 Piston complete
 Cushioning seals
 Piston rod bearing
 Scraper ring
 Piston rod seal
 O-rings

Material specification, see page 11





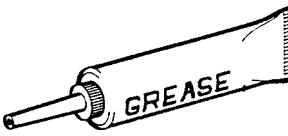

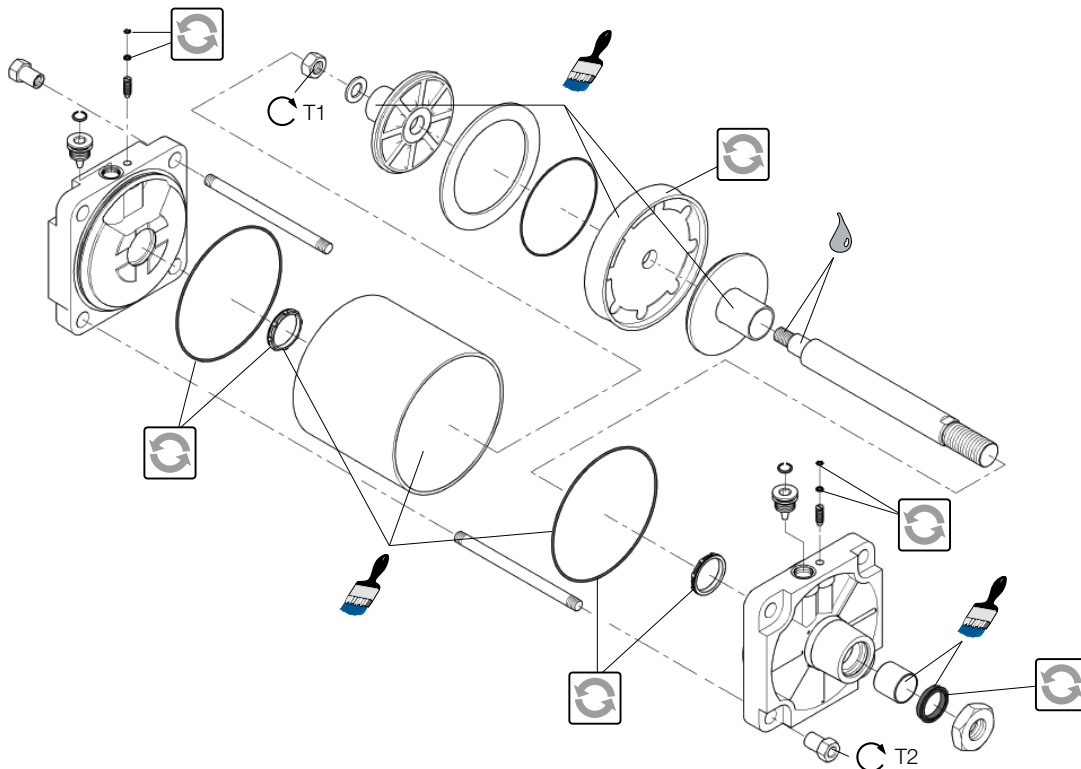

Cyl.bore mm	Standard	High Temp.
160	PD23013	PD26995
200	PD25006	PD27427
250	PD25872	PD27976

	Standard	4g tube	KL8220
	High temperature	4g tube	KL8220

Cyl.bore mm	Through rod Standard temperature
160	P1D-6SRNF
200	P1D-6TRNF
250	P1D-6URNF

Seal kit for bores Ø160 - Ø250 mm



-  = Included in seal kit
-  = Lubricated with grease
-  = Socket head
-  = Locking fluid
-  = Tightening torque
-  = Nut A/F

Loctite LT638 locking fluid must be used

Cyl.-dia mm	Plastic piston T1 Nm	NV mm	T2 Nm	NV mm
160	100	30	85	27
200	100	30	95	27
250	120	36	140	41

Seal Kits

Complete seal kits consisting of:

- Piston complete
- Cushioning seals
- Piston rod bearing
- Scraper ring
- Piston rod seal
- O-rings

Material specification, see page 12





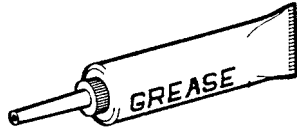



Cyl.bore mm	Standard	High Temp.
320	KL7339	KL7340

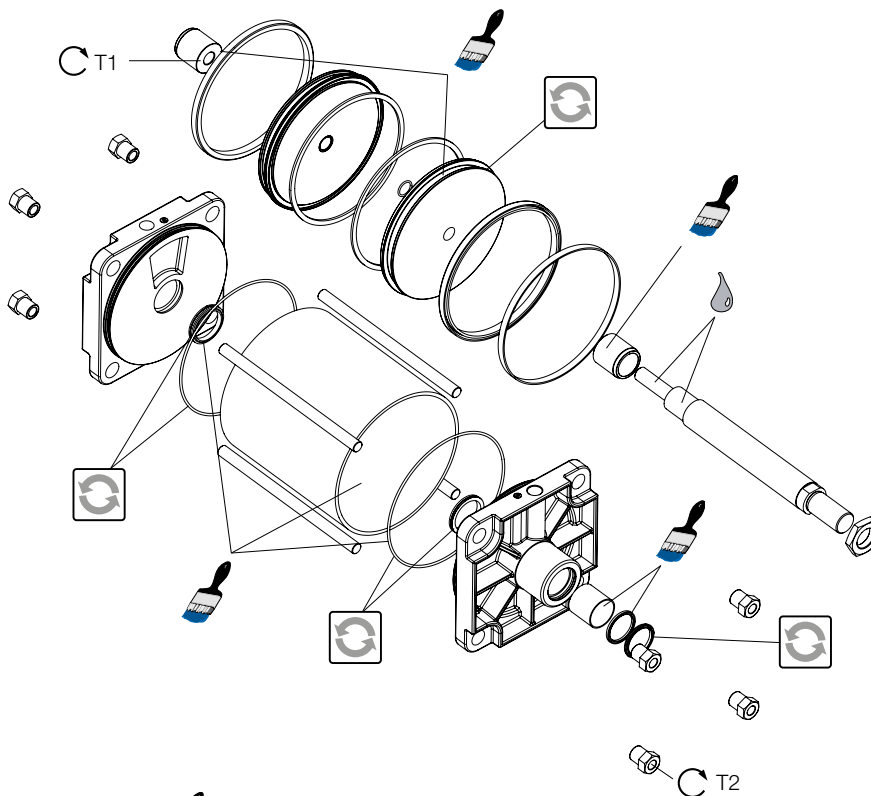

	Standard	4g tube	KL8220
	High temperature	4g tube	KL8220

Cyl.bore mm	Through rod Standard temperature
320	P1D-6VRNF

Seal kit for bore Ø320 mm



-  = Included in seal kit
-  = Lubricated with grease
-  = Socket head
-  = Locking fluid
-  = Tightening torque
-  = Nut A/F

Cyl.-dia	Piston			
mm	T1 Nm	NV mm	T2 Nm	NV mm
320	250	30	200	41

Loctite LT638 locking fluid must be used

Order code key, spare parts

1	2	3	4	5	6	7	8	9	10	11	12	13	14	15
P	1	D	-	8	0	3	2	D	G	-	0	1	0	0

8 Spare parts

Cylinder dia. mm
032
040
050
063
080
100
125
160
200
250
320

Piston rod*
D Standard external thread
G Standard internal thread
H Through rod ext. threads
J Through rod int. threads
Cylinder barrel
B Cylindrical (for tie rod)
Tie rod
T Tie rod (order 4 for a cylinder)

Piston rod
G Stainless steel
H Hard-chromium plated
J Acid-resistant steel
K Chromium plated stainless
Cylinder barrel
A Aluminium

* 2 piston rod pieces delivered in one set if through rod option selected

Stroke** (mm) e.g. 0100 = 100 mm
Any stroke up to max. 2800 mm.

** When ordering piston rods for cylinders with an extended piston rod, add together the stroke and the extension in the order key.
For example, a cylinder with stroke 100 mm and a piston rod extension of 25 mm is ordered with 0125 in the order number.

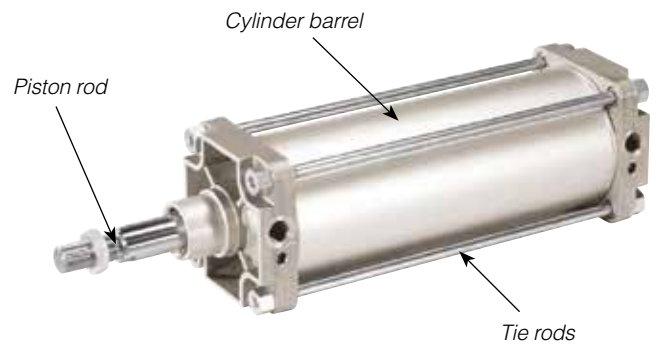

Specifying air quality (purity) in accordance with ISO8573-1:2010, the international standard for Compressed Air Quality

ISO8573-1 is the primary document used from the ISO8573 series as it is this document which specifies the amount of contamination allowed in each cubic metre of compressed air.

ISO8573-1 lists the main contaminants as Solid Particulate, Water and Oil. The purity levels for each contaminant are shown separately in tabular form, however for ease of use, this document combines all three contaminants into one easy to use table.

ISO8573-1:2010 CLASS	Solid Particulate			Mass Concentration mg/m ³	Water		Oil
	Maximum number of particles per m ³				Vapour Pressure Dewpoint	Liquid g/m ³	Total Oil (aerosol liquid and vapour) mg/m ³
	0,1 - 0,5 micron	0,5 - 1 micron	1 - 5 micron				
0	As specified by the equipment user or supplier and more stringent than Class 1						
1	≤ 20 000	≤ 400	≤ 10	-	≤ -70 °C	-	0,01
2	≤ 400 000	≤ 6 000	≤ 100	-	≤ -40 °C	-	0,1
3	-	≤ 90 000	≤ 1 000	-	≤ -20 °C	-	1
4	-	-	≤ 10 000	-	≤ +3 °C	-	5
5	-	-	≤ 100 000	-	≤ +7 °C	-	-
6	-	-	-	≤ 5	≤ +10 °C	-	-
7	-	-	-	5 - 10	-	≤ 0,5	-
8	-	-	-	-	-	0,5 - 5	-
9	-	-	-	-	-	5 - 10	-
X	-	-	-	> 10	-	> 10	> 10

Specifying air purity in accordance with ISO8573-1:2010

When specifying the purity of air required, the standard must always be referenced, followed by the purity class selected for each contaminant (a different purity class can be selected for each contamination if required).

An example of how to write an air quality specification is shown below:

ISO 8573-1:2010 Class 1.2.1

ISO 8573-1:2010 refers to the standard document and its revision, the three digits refer to the purity classifications selected for solid particulate, water and total oil. Selecting an air purity class of 1.2.1 would specify the following air quality when operating at the standard's reference conditions :

Class 1 - Particulate

In each cubic metre of compressed air, the particulate count should not exceed 20,000 particles in the 0.1 - 0.5 micron size range, 400 particles in the 0.5 - 1 micron size range and 10 particles in the 1 - 5 micron size range.

Class 2 - Water

A pressure dewpoint (PDP) of -40°C or better is required and no liquid water is allowed.

Class 1 - Oil

In each cubic metre of compressed air, not more than 0.01mg of oil is allowed. This is a total level for liquid oil, oil aerosol and oil vapour.

ISO8573-1:2010 Class zero

- **Class 0 does not mean zero contamination.**
- **Class 0 requires the user and the equipment manufacturer to agree contamination levels as part of a written specification.**
- **The agreed contamination levels for a Class 0 specification should be within the measurement capabilities of the test equipment and test methods shown in ISO8573 Pt 2 to Pt 9.**
- **The agreed Class 0 specification must be written on all documentation to be in accordance with the standard.**
- **Stating Class 0 without the agreed specification is meaningless and not in accordance with the standard.**
- **A number of compressor manufacturers claim that the delivered air from their oil-free compressors is in compliance with Class 0.**
- **If the compressor was tested in clean room conditions, the contamination detected at the outlet will be minimal. Should the same compressor now be installed in typical urban environment, the level of contamination will be dependent upon what is drawn into the compressor intake, rendering the Class 0 claim invalid.**
- **A compressor delivering air to Class 0 will still require purification equipment in both the compressor room and at the point of use for the Class 0 purity to be maintained at the application.**
- **Air for critical applications such as breathing, medical, food, etc typically only requires air quality to Class 2.2.1 or Class 2.1.1.**
- **Purification of air to meet a Class 0 specification is only cost effective if carried out at the point of use.**

Introduction to the ATEX directive

Explosive atmospheres

Directive 94/9/EC defines an explosive atmosphere as a mixture of:

- a) **flammable substances** – gases, vapours, mists or dusts
 - b) with **air**
 - c) under specific **atmospheric conditions**
 - d) in which, after ignition has occurred, combustion spreads to the entire flammable mixture
- (NB: with regard to dust, it may be that not all dust is combusted after ignition has occurred)

An atmosphere with the potential to become an explosive atmosphere during operating conditions and/or under the influence of the surroundings is defined as a **potentially explosive atmosphere**. Products covered by directive 94/9/EC are defined as intended for use in potentially explosive atmospheres.

Harmonised European ATEX standard

The European Union has adopted two harmonised directives in the field of health and safety. The directives are known as ATEX 100a and ATEX 137.

Directive ATEX 100a (94/9/EC) lays down minimum safety requirements for products intended for use in potentially explosive atmospheres in European Union member states. Directive ATEX 137 (99/92/EC) defines minimum requirements for health and safety at the workplace, for working conditions and for the handling of products and materials in potentially explosive atmospheres. This directive also divides the workplace into **zones** and defines criteria by which products are **categorised** within these zones.

The table below describes the **zones** in an installation where there is a potential for explosive atmospheres. The **owner** of the installation must analyse and assess the area in which the explosive gas/dust mixture may occur, and if necessary must divide it into **zones**. This process of zoning then allows the correct plant and equipment to be selected for use in the area.

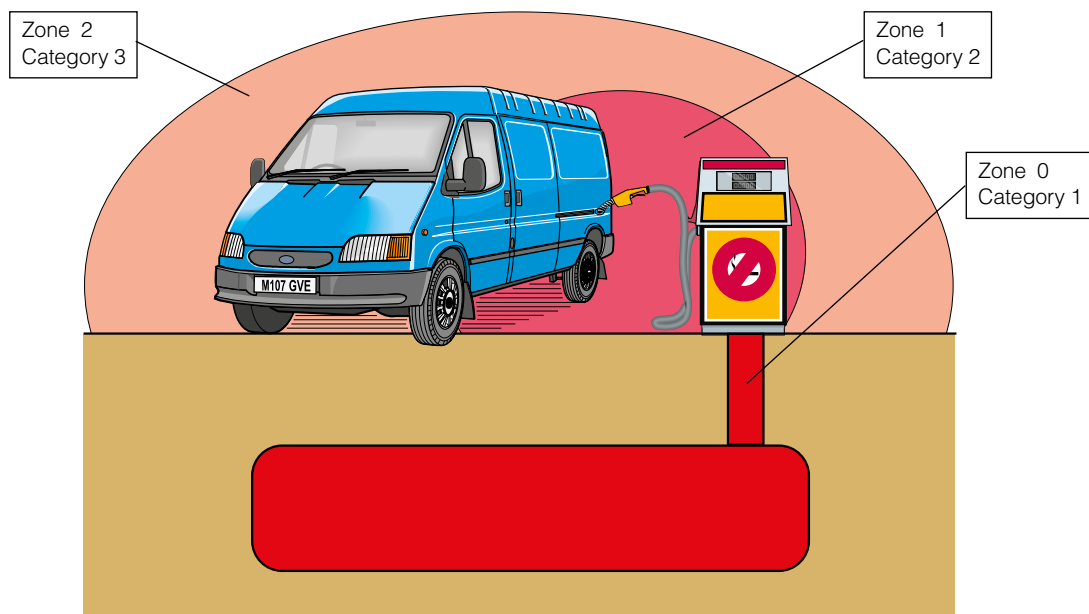

Zones		Presence of potentially explosive atmosphere	Type of risk
Gas G	Dust D		
0	20	Present continuously or for long periods	Permanent
1	21	Likely to occur in normal operation occasionally	Potential
2	22	Not likely to occur in normal operation but, if it does occur, will persist for a short period only	Minimal

The ATEX directive has been in force throughout the European Union since 1 July 2003, replacing the existing divergent national and European legislation relating to explosive atmospheres. Please note that for the first time, the directive covers mechanical, hydraulic and pneumatic equipment and not just electrical equipment as before.

With regard to the **Machinery directive** 98/37/EC, note that a number of external requirements in 94/9/EC refer to hazards arising from potentially explosive atmospheres, where the Machinery directive only contains general requirements relating to explosion safety (Annex I 1.5.7).

As a result, directive 94/9/EC (ATEX 100a) takes precedence over the Machinery directive with regard to explosion protection in potentially explosive atmospheres. The requirements in the Machinery directive are applicable to all other risks relating to machinery.

P1D-T Pneumatic ISO Cylinders - Ø160 - Ø320 mm

Levels of protection for the various equipment categories

The various equipment categories must be capable of operating in accordance with the manufacturer's operating specifications at defined levels of protection.

Level of protection	Category		Type of protection	Operating specifications
	Group I	Group II		
Very high	M1		Two independent means of protection or safety, ensuring that the equipment remains functional even in the event of two faults occurring independently of each other	The equipment remains energised and functional even with an explosive atmosphere present
Very high		1	Two independent means of protection or safety, ensuring that the equipment remains functional even in the event of two faults occurring independently of each other	The equipment remains energised and functional in zones 0, 1, 2 (G) and/or zones 20, 21, 22 (D)
High	M2		Protection suitable for normal operation and severe operating conditions	The equipment is de-energised in the event of an explosive atmosphere
High		2	Protection suitable for normal operation and frequent faults, or equipment in which faults normally have to be taken into account	The equipment remains energised and functional in zones 1, 2 (G) and/or zones 21, 22 (D)
Normal		3	Protection suitable for normal operation	The equipment remains energised and functional in zones 2 (G) and/or zones 22 (D)

Definition of groups (EN 1127-1)

Group I Equipment intended for use in underground parts of mines as well as those parts of surface installations of such mines likely to be endangered by flammable vapours and/or flammable dusts.

Group II Equipment intended for use in other places exposed to explosive atmospheres.

Group	I mines, combustible vapours		II other potentially explosive atmospheres (gases, dust)					
	M1	M2	1		2		3	
Category								
Atmosphere*			G	D	G	D	G	D
Zone			0	20	1	21	2	22

G = gas and D = dust

Temperature classes

Classification of flammable gases and vapours on the basis of ignition temperature

Temperature class	Ignition temperature °C
T1	Over 450
T2	(300) – 450
T3	(200) – 300
T4	(135) – 200
T5	(100) – 135
T6	(85) – 100

Declaration of conformity

The product catalogues contain copies of the declaration of conformity demonstrating that the product meets the requirements of directive 94/9/EC.

The declaration is only valid in conjunction with the instructions contained in the installation manual relating to the safe use of the product throughout its service life.

The instructions relating to the conditions in the surrounding area are particularly important, as the certificate is invalidated if the instructions are found not to have been adhered to during operation of the product. If there is any doubt as to the validity of the certificate of conformity, contact Parker Hannifin customer service.

Operation, installation and maintenance

The installation manual of the product contains instructions relating to the safe storage, handling, operation and servicing of the product.

The manual is available in different languages, and can be downloaded from www.parker.com/euro_pneumatic.

This document must be made accessible in a suitable place near where the product is installed. It is used as a reference for all personnel authorised to work with the product throughout its service life. We, the manufacturer, reserve the right to modify, extend or improve the installation manual in the interests of the users.

For more information about ATEX see EUs homepage: <http://europa.eu.int/comm/enterprise/atex/>

Safety instructions for the P1D-T cylinder with accessories

Supplementary safety instructions for installation of ATEX certified cylinders.

The safety instructions in this document are valid for the ATEX certified P1D-T cylinders, bore 160 - 320mm, as per below with reference to the order code key in the product catalogue.

P1D-T***MS-****-EXNN

All strokes in the range 50 - 1000mm

Serious, even fatal, damage or injury may be caused by the hot moving parts of the P1D-T cylinders in the presence of explosive gas mixtures and concentrations of dust.

All installation, connection, commissioning, servicing and repair work on P1D-T cylinders must be carried out by qualified personnel taking account of the following

- These instructions
- Markings on the cylinder
- All other planning documents, commissioning instructions and connection diagrams associated with the application.
- Provisions and requirements specific to the application
- National/international regulations (explosion protection, safety and accident prevention)

Real life applications

P1D-T cylinders are designed to provide linear movement in industrial applications, and should only be used in accordance with the instructions in the technical specifications in the catalogue, and within the operating range indicated on the rating plate.

The cylinders meet the applicable standards and requirements of directive 94/9/EC (ATEX)

The cylinders must not be used underground in mines susceptible to firedamp and/or flammable dusts. The cylinders are intended for use in areas in which explosive atmospheres caused by gases, vapours or mists of flammable liquids, or air/dust mixtures may be expected to occur during normal use (infrequently)

Checklist

Before using the cylinders in an Ex-area, you should check the following:

Do the specifications of the P1D-T cylinder match the Ex-classification of the area of use in accordance with directive 94/9/EC (previously ATEX 100a)

- Equipment group
- Ex-equipment category
- Ex-zone
- Temperature class
- Max. surface temperature

1. When installing the P1D-T cylinder, is it certain that there is no potentially explosive atmosphere, oil, acids, gases, vapours or radiation?
2. Is the ambient temperature as specified in the technical data in the catalogue at all times?
3. Is it certain that the P1D-T cylinder is adequately ventilated and that no forbidden additional heat is added?
4. Are all the driven mechanical components ATEX certified?
5. Check that the P1D-T cylinder is safely earthed.
6. Check that the P1D-T cylinder is supplied with compressed air. Explosive gas mixtures must not be used for driving the cylinder.
7. Check that the P1D-T cylinder is not equipped with a metal scraper ring (special version).

Installation requirements in Ex-areas

- The temperature of the supply air must not exceed the ambient temperature.
- The P1D-T cylinder may be installed in any position.
- The P1D-T cylinder must not be installed where there is a risk of mechanical contact with any surrounding part or component.
- An air treatment unit must be attached to the inlet of the P1D-T cylinder.
- The P1D-T cylinder must be connected to earth at all times, through its support, a metallic tube or separate conductor.
- The outlet of the P1D-T cylinder must not be open within an Ex-area, but must be connected to the silencer or, preferably, piped and released outside the Ex-area.
- The P1D-T cylinder may only drive units that are ATEX certified.
- Ensure that the P1D-T cylinder is not exposed to forces greater than those permitted in accordance with the catalogue
- The P1D-T cylinder must be supplied with compressed air. Explosive gas mixtures must not be used
- P1D-T cylinders with metal scraper rings must not be used in Ex-areas

Inspecting cylinders during operation

The P1D-T cylinder must be kept clean on the outside, and a layer of dust/dirt thicker than 1 mm must never be allowed to form. Inspect and verify that the cylinder, with attachments, compressed air fittings, hoses, tubes, etc. meet the standards of "safe" installation.

Spare parts

Only spare parts, kits etc. supplied by Parker Hannifin may be used for repair and maintenance of the P1D-T cylinders.

Marking of ATEX certified P1D-T cylinders

The ATEX certified P1D-T cylinders, bore 160 - 320mm, as per below with reference to the order code key in the product catalogue have an ATEX certification marking as shown further below.

P1D-T***MS-****-EXNN

All strokes in the range 50 - 1000mm

  II 2GD c T4 120 °C



Communauté Européenne = EU

CE on the product shows that Parker Hannifin products meet one or more EU directives



Ex means that this product is intended for use in potentially explosive atmospheres

II

Stands for the equipment group (I = mines and II = other hazardous areas)

2GD

Stands for equipment category 2G means the equipment can be used in zones 1 and 2 where there is a risk involving gases, vapours or mists of combustible liquids and 2D in zones 21 and 22 where there is a risk involving dusts. 2GD Means the equipment can be used in zones 1, 2, 21 and 22.

c

Safe design (prEN 13463-5)

T4

If equipment is in temperature class T4, the maximum surface temperature must not exceed 135 °C. (To guarantee this, the product has been tested to ensure that the maximum is 130 °C. This provides a safety margin of 5 °K.)

120 °C

Maximum permitted surface temperature on P1D-S cylinder in atmospheres containing potentially explosive dusts.

Supplementary safety instructions for P8S-GPFLX/EX sensors installed in Ex-areas

Serious, even fatal, damage or injury may be caused by the hot moving parts of the P1D-T cylinders in the presence of explosive gas mixtures and concentrations of dust.

Instructions for use

Safety instructions

- Cylinder sensor ATEX classed for category II3G and II3D
- Ambient temperature $T_a = -20\text{ °C}$ to $+45\text{ °C}$
- Temperature class T4, or max. surface temperature of $T = 135\text{ °C}$
- Protection class IP67
- Read installation instructions before startup
- Installation, connection and commissioning must be carried out by trained personnel

Applications

- This sensor is designed for use in the T-groove of cylinders, and detects the magnetic field in potentially explosive areas. The sensor can only be installed in the T-groove of these cylinders.
- The sensor may also be installed on round cylinders by means of the following attachments:

P8S-TMC01 Suitable for P1S and P1A diameter 10 - 25 mm

P8S-TMC02 Suitable for P1S diameter 32 - 63 mm

P8S-TMC03 Suitable for P1S diameter 80 - 125 mm

The following data applies to these attachments:

- Ambient temperature $T_a = 0\text{ °C}$ to 45 °C
- Low energy absorption to EN 50 021
- The sensor may also be installed on tie-rod cylinders or profile cylinders by means of this attachment:

P8S-TMA0X Suitable for P1D-T diameter 32 - 125 mm, P1E-T diameter 160 – 200 mm and C41 diameter 160 – 200 mm

Installation

General: The sensor must be protected from UV radiation. The cable must be installed such that it is protected from external influences, for example it may be necessary to attach an external strain relief to the cable.

Technical data for sensor

Operating voltage $U_b = 18$ to 30 V DC

Max. load current $I_a \leq 70\text{ mA}$

Ambient temperature: -20 °C to 45 °C

Commissioning

When connecting the sensor to a power source, please pay attention to the following

- a) the load data (operating voltage, continuous load current)
- b) the wiring diagram for the sensor

Maintenance

Our P8S-GPFLX/EX cylinder sensor is maintenance free, but the cable connections should be checked at regular intervals.

The sensor must be protected from UV radiation. The sensor must be kept clean on the outside, and a layer of dirt thicker than 1 mm must never be allowed to form. Strong solvents should not be used for cleaning as they may damage the sensor.

P8S-GPFLX/EX cylinder sensor

II3G EEx nA II T4X
II3D 135 °C IP67



Communauté Européenne = EU

CE on the product shows that Parker Hannifin products meet one or more EU directives



Ex means that this product is intended for use in potentially explosive atmospheres

II

Stands for the equipment group (I = mines and II = other hazardous areas)

3G

Stands for the equipment category 3G means the equipment can be used in zone 2 where there is a risk involving gases, vapours or mists of combustible liquids

EEx

EEx means that this is an electrical product intended for use in Ex-areas

nA II

n Not ignitable to EN50021, A Explosion group tested with acetone, ethanol, toluene and xylene; II Not for use in the mining industry

T4 X

If equipment is in temperature class T4, the maximum surface temperature must not exceed 135 °C . (To guarantee this, the product has been tested to ensure that the maximum is 130 °C . This provides a safety margin of 5 °C .) X Must be installed in accordance with the installation manual

3D

Stands for equipment category 3D in zone 22 where there is a risk involving dusts.

135 °C

Maximum permitted surface temperature on the motor in atmospheres containing potentially explosive dusts.

IP67

Satisfies protection class IP67

Components such as cylinder attachments, tube fittings, tubes, etc.

Components

Parker Hannifin guarantees that our cylinder mountings, tube fittings, tubes, etc. are not ignition sources and are therefore not subject to the provisions of the ATEX directive.

A component means any item essential to the safe functioning of equipment and protective systems but with no autonomous function.

Components intended for incorporation into equipment or protective systems which are accompanied by an attestation of conformity with the ATEX directive, including a statement of their characteristics and how they must be incorporated into products, are considered to conform to the applicable provisions of directive 94/9/EC. Ex-components as defined in the European standard EN 50014 are components in the sense of the ATEX directive 94/9/EC as well. Components must not have the CE marking affixed unless otherwise required by other directives.

Examples of components:

- terminals
- push buttons assemblies
- relays
- empty flameproof enclosures
- ballasts for fluorescent lamps
- meters (e.g. moving coil)
- encapsulated relays and contactors, with terminals and/or flying leads

Parker Worldwide

Europe, Middle East, Africa

AE – United Arab Emirates,
Dubai

Tel: +971 4 8127100
parker.me@parker.com

AT – Austria, Wiener Neustadt

Tel: +43 (0)2622 23501-0
parker.austria@parker.com

AT – Eastern Europe, Wiener
Neustadt

Tel: +43 (0)2622 23501 900
parker.easteurope@parker.com

AZ – Azerbaijan, Baku

Tel: +994 50 2233 458
parker.azerbaijan@parker.com

BE/LU – Belgium, Nivelles

Tel: +32 (0)67 280 900
parker.belgium@parker.com

BY – Belarus, Minsk

Tel: +375 17 209 9399
parker.belarus@parker.com

CH – Switzerland, Etoy

Tel: +41 (0)21 821 87 00
parker.switzerland@parker.com

CZ – Czech Republic, Klecany

Tel: +420 284 083 111
parker.czechrepublic@parker.com

DE – Germany, Kaarst

Tel: +49 (0)2131 4016 0
parker.germany@parker.com

DK – Denmark, Ballerup

Tel: +45 43 56 04 00
parker.denmark@parker.com

ES – Spain, Madrid

Tel: +34 902 330 001
parker.spain@parker.com

FI – Finland, Vantaa

Tel: +358 (0)20 753 2500
parker.finland@parker.com

FR – France, Contamine s/Arve

Tel: +33 (0)4 50 25 80 25
parker.france@parker.com

GR – Greece, Athens

Tel: +30 210 933 6450
parker.greece@parker.com

HU – Hungary, Budapest

Tel: +36 23 885 475
parker.hungary@parker.com

IE – Ireland, Dublin

Tel: +353 (0)1 466 6370
parker.ireland@parker.com

IT – Italy, Corsico (MI)

Tel: +39 02 45 19 21
parker.italy@parker.com

KZ – Kazakhstan, Almaty

Tel: +7 7272 505 800
parker.easteurope@parker.com

NL – The Netherlands, Oldenzaal

Tel: +31 (0)541 585 000
parker.nl@parker.com

NO – Norway, Asker

Tel: +47 66 75 34 00
parker.norway@parker.com

PL – Poland, Warsaw

Tel: +48 (0)22 573 24 00
parker.poland@parker.com

PT – Portugal, Leca da Palmeira

Tel: +351 22 999 7360
parker.portugal@parker.com

RO – Romania, Bucharest

Tel: +40 21 252 1382
parker.romania@parker.com

RU – Russia, Moscow

Tel: +7 495 645-2156
parker.russia@parker.com

SE – Sweden, Spånga

Tel: +46 (0)8 59 79 50 00
parker.sweden@parker.com

SK – Slovakia, Banská Bystrica

Tel: +421 484 162 252
parker.slovakia@parker.com

SL – Slovenia, Novo Mesto

Tel: +386 7 337 6650
parker.slovenia@parker.com

TR – Turkey, Istanbul

Tel: +90 216 4997081
parker.turkey@parker.com

UA – Ukraine, Kiev

Tel +380 44 494 2731
parker.ukraine@parker.com

UK – United Kingdom, Warwick

Tel: +44 (0)1926 317 878
parker.uk@parker.com

ZA – South Africa, Kempton Park

Tel: +27 (0)11 961 0700
parker.southafrica@parker.com

North America

CA – Canada, Milton, Ontario

Tel: +1 905 693 3000

US – USA, Cleveland

Tel: +1 216 896 3000

Asia Pacific

AU – Australia, Castle Hill

Tel: +61 (0)2-9634 7777

CN – China, Shanghai

Tel: +86 21 2899 5000

HK – Hong Kong

Tel: +852 2428 8008

IN – India, Mumbai

Tel: +91 22 6513 7081-85

JP – Japan, Tokyo

Tel: +81 (0)3 6408 3901

KR – South Korea, Seoul

Tel: +82 2 559 0400

MY – Malaysia, Shah Alam

Tel: +60 3 7849 0800

NZ – New Zealand, Mt Wellington

Tel: +64 9 574 1744

SG – Singapore

Tel: +65 6887 6300

TH – Thailand, Bangkok

Tel: +662 186 7000

TW – Taiwan, Taipei

Tel: +886 2 2298 8987

South America

AR – Argentina, Buenos Aires

Tel: +54 3327 44 4129

BR – Brazil, Sao Jose dos Campos

Tel: +55 800 727 5374

CL – Chile, Santiago

Tel: +56 2 623 1216

MX – Mexico, Apodaca

Tel: +52 81 8156 6000

European Product Information Centre

Free phone: 00 800 27 27 5374

(from AT, BE, CH, CZ, DE, DK, EE, ES, FI,
FR, IE, IL, IS, IT, LU, MT, NL, NO, PL, PT, RU,
SE, SK, UK, ZA)

Parker Hannifin Ltd.

Tachbrook Park Drive
Tachbrook Park,
Warwick, CV34 6TU
United Kingdom
Tel.: +44 (0) 1926 317 878
Fax: +44 (0) 1926 317 855
parker.uk@parker.com
www.parker.com

