

Parking brakes Spring Applied Hydraulic Released

For High Torque piston motors

aerospace
climate control
electromechanical
filtration
fluid & gas handling
hydraulics
pneumatics
process control
sealing & shielding



ENGINEERING YOUR SUCCESS.

GENERAL	Introduction	3
	Technical tips	3
	Brakes data	4
	Brake selection	5
	Radial piston motor coupling	5
B190C	Dimensions and ordering information	6
B300D	Dimensions and ordering information	7
B450E	Dimensions and ordering information	8
B700F	Dimensions and ordering information	9
B1100G	Dimensions and ordering information	10
B1800H	Dimensions and ordering information	11
B2800I	Dimensions and ordering information	12
B4500L	Dimensions and ordering information	13
B7000M	Dimensions and ordering information	14
	Customizations	15
	Sales Offices	16



WARNING — USER RESPONSIBILITY

FAILURE OR IMPROPER SELECTION OR IMPROPER USE OF THE PRODUCTS DESCRIBED HEREIN OR RELATED ITEMS CAN CAUSE DEATH, PERSONAL INJURY AND PROPERTY DAMAGE.

- This document and other information from Parker-Hannifin Corporation, its subsidiaries and authorized distributors provide product or system options for further investigation by users having technical expertise.
- The user, through its own analysis and testing, is solely responsible for making the final selection of the system and components and assuring that all performance, endurance, maintenance, safety and warning requirements of the application are met. The user must analyze all aspects of the application, follow applicable industry standards, and follow the information concerning the product in the current product catalog and in any other materials provided from Parker or its subsidiaries or authorized distributors.
- To the extent that Parker or its subsidiaries or authorized distributors provide component or system options based upon data or specifications provided by the user, the user is responsible for determining that such data and specifications are suitable and sufficient for all applications and reasonably foreseeable uses of the components or systems.

Offer of Sale

Please contact your Parker representation for a detailed "Offer of Sale".

INTRODUCTION

The Calzoni brake series is a “spring applied - hydraulic release” multi-disc wet parking brake, that has been designed for those applications where it is absolutely necessary to hold the system under an external torque. The maximum braking torque is achieved when the brake is not fed.

Typical characteristics of the Calzoni brakes are:

- direct coupling with radial piston Calzoni motor types;
- compact design;
- thorough quality control and thorough material and product testing;
- double range of drum roller bearing for heavy external loads (on request);
- no oil refilling problem;
- lower braking torque units available on Customer request for torque limiting devices.

Application examples:

- winches;
- slewing drives;
- parking brake for track driving;
- mining industry;
- industrial applications.

TECHNICAL TIPS

Hydraulic motors usually have a leakage connection, which means that a hydraulic motor can never hold a load for a long period without a pressure feeding. So, a mechanical brake is used to hold the load on the motor in place.

The brake is operated by a single-acting piston (1) with opposing springs (2) between the piston and the cap end (3). During load braking and stop, the springs press against the piston blocking the discs.

Hydraulic pressure is required to release or “hold off” the brake and during normal operation the brake is pressurized in the released position: any function which reduces the hydraulic system below the release pressure of the brake will cause the brake to be applied.

The picture below represents a typical hydraulic circuit where a brake is used to hold the load when no hydraulic pressure is used to feed the motor.

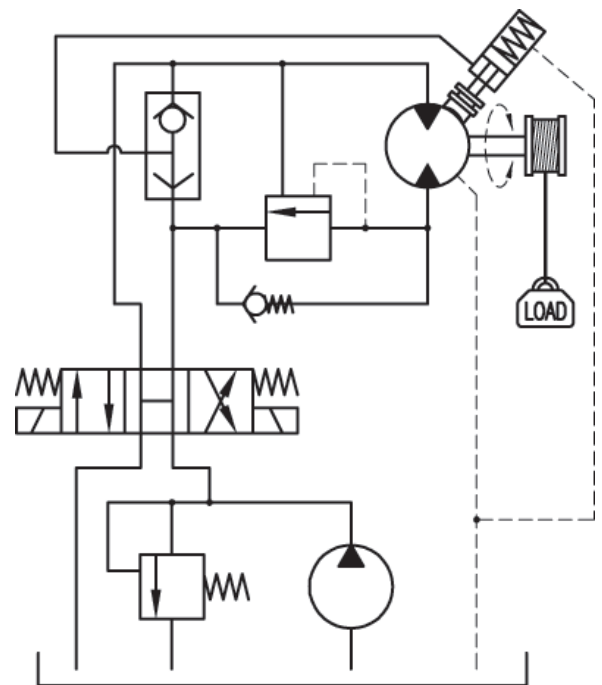
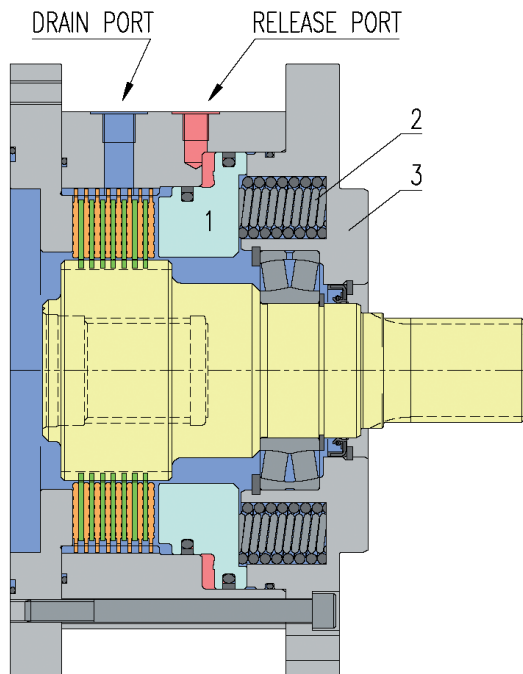

When the directional control valve is shifted, hydraulic pressure releases the mechanical brake and allows the load to be moved. When no feed pressure is supplied to the brake, the brake springs push the brake disks holding the load.

Parking Brakes For Calzoni HTLS (radial) Piston Motors

BRAKES DATA

CHARACTERISTIC			BRAKE SIZE								
			B190C	B300D	B450E	B700F	B1100G	B1800H	B2800I	B4500L	B7000M
Static braking torque	Max.	Nm	1500	1900	3200	4500	7100	12000	18300	30800	46200
	Min.	Nm	1400	1700	2900	4000	6000	10300	15200	27000	37900
Dynamic braking torque	Max.	Nm	1000	1200	2100	2900	4500	7700	11700	19800	29700
	Min.	Nm	900	1100	1900	2700	4100	7000	10400	18200	26100
Release pressure		bar	30	30	30	30	30	27	30	30	30
Max. continuous release pressure		bar	250								
Max. peak release pressure		bar	420								
Max. speed		rpm	1250	1000	850	700	580	500	370	260	260
Weight		Kg	27	29	69	75	78	176	225	460	652
Inertia of rotating parts		kg m ²	0,0046	0,0057	0,021	0,025	0,041	0,14	0,16	0,73	0,91
Working volume	New	cm ³	17	17	30	30	36	47	64	98	91
	Wear	cm ³	34	36	53	63	94	115	158	202	247

IMPORTANT NOTES:

The braking force values are based on coefficient friction $\mu = 0.14$.

The brake can be used in dynamic conditions only in case of emergency (pump failure).

The release pressure represents the pressure value to completely release the brake.

For correct operations, the hydraulic release pressure to the brake must fall to zero. Any residual release back pressure applied to the brake, as shown in the graph below, will degrade braking torque and may result in hazardous conditions.

The brakes are suitable for wet operation (please contact Parker Hannifin in case dry operation are required).

When intending to use low flammable liquids and bio-oils please consult Parker Hannifin.

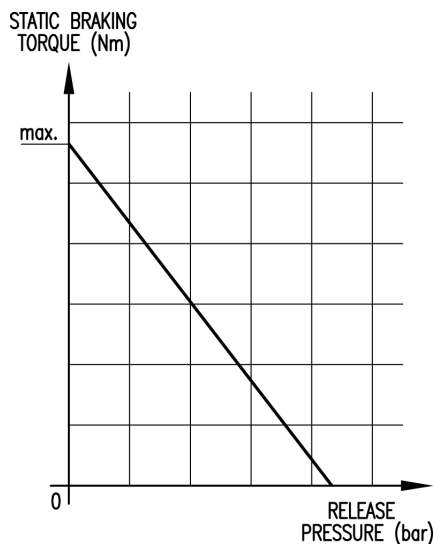

Parking Brakes For Calzoni HTLS (radial) Piston Motors

BRAKE SELECTION

For ordering information you should select:

- brake size;
- brake input shaft;
- brake output shaft ;
- seal type.

The brake size has to be selected according to the required braking torque. The static braking torque has to be greater than the required torque. The brakes in this catalogue are suitable for direct coupling with Parker Calzoni radial piston motors: in this case the brake size can be selected according to the motor size (see table below).

The brake input shaft has to be selected according to the motor shaft (see overall dimension drawings). In case the motor is a Calzoni radial piston type, the shaft code is the same of the brake input shaft code.

The brake output shaft can be selected according to the application the brake has to be assembled with.

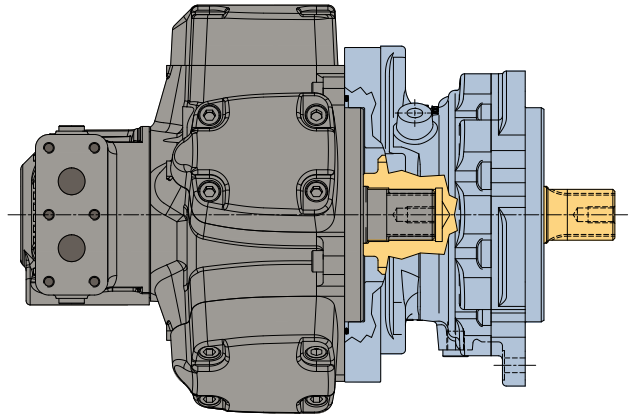

Assembly example with radial piston motor:
Motor MR1100G-**N1** ... (motor shaft code N1)
Brake B1100G-**N1** ... (brake input shaft code N1)

RADIAL PISTON MOTOR COUPLING

BRAKE SIZE	Suitable for radial piston motor type
B190C	MR125C ...
	MR160C ...
	MR190C ...
B300D	MR200D ...
	MR250D ...
	MR300D ...
	MRE330D ...
	MRA400D ...
	MRD300D ...
	MRDE330D ...
B450E	MR305E ...
	MR450E ...
	MRE500E ...
	MRD450E ...
	MRDE500E ...
B700F	MRV450E ...
	MR600F ...
	MR700F ...
	MRE800F ...
	MRD700F ...
	MRDE800F ...
	MRV700F ...
MRVE800F ..	
B1100G	MR1100G ...
	MRE1400G ...
	MRA1600G ...
	MRD1100G ...
	MRDE1400G ...
MRV1100G ...	
MRVE1400G ...	

BRAKE SIZE	Suitable for radial piston motor type
B1800H	MR1600H ...
	MR1800H ...
	MRE2100H ...
	MRA2400H ...
	MRD1800H ...
	MRDE2100H ...
	MRV1800H ...
MRVE2100H ...	
B2800I	MR2400I ...
	MR2800I ...
	MRE3100I ...
	MRA3500I ...
	MRD2800I ...
	MRDE3100I ...
B4500L	MRV2800I ...
	MRVE3100I ...
	MR3600L ...
	MR4500L ...
	MRE5400L ...
	MRA6000L ...
	MRA6300L ...
MRD4500L ...	
B7000M	MRDE5400L ...
	MRV4500L ...
	MRVE5400L ...
	MR6500M ...
	MR7000M ...
	MRE8200M ...
	MRD7000M ...
MRDE8200M ...	
MRV7000M ...	
MRVE8200M ...	

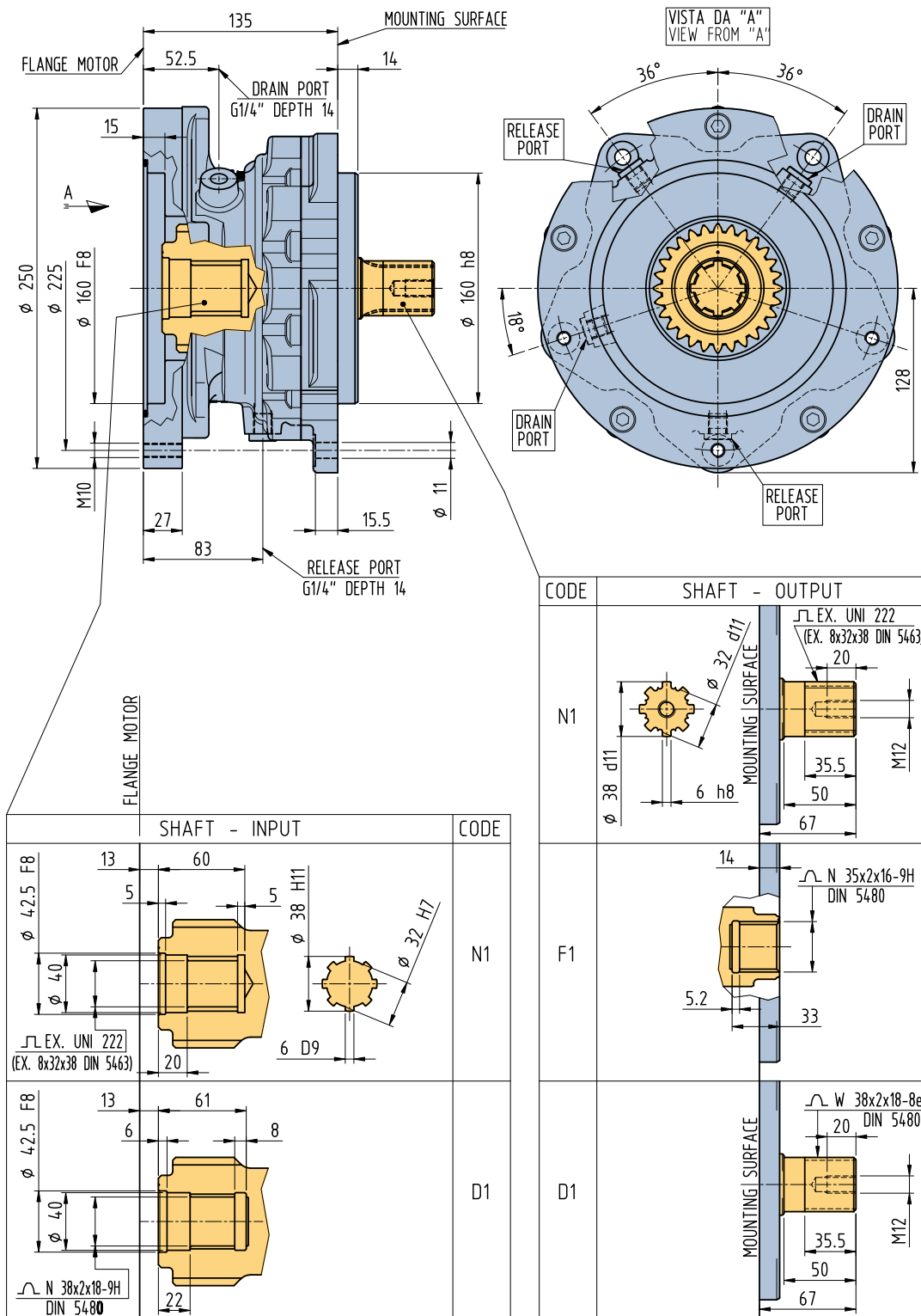

ORDERING INFORMATION

B190C	-			
BRAKE TYPE	-	SHAFT OUTPUT	SHAFT INPUT	SEAL TYPE

CODE	SEAL TYPE
N1	NBR: mineral oil
V1	FPM seal

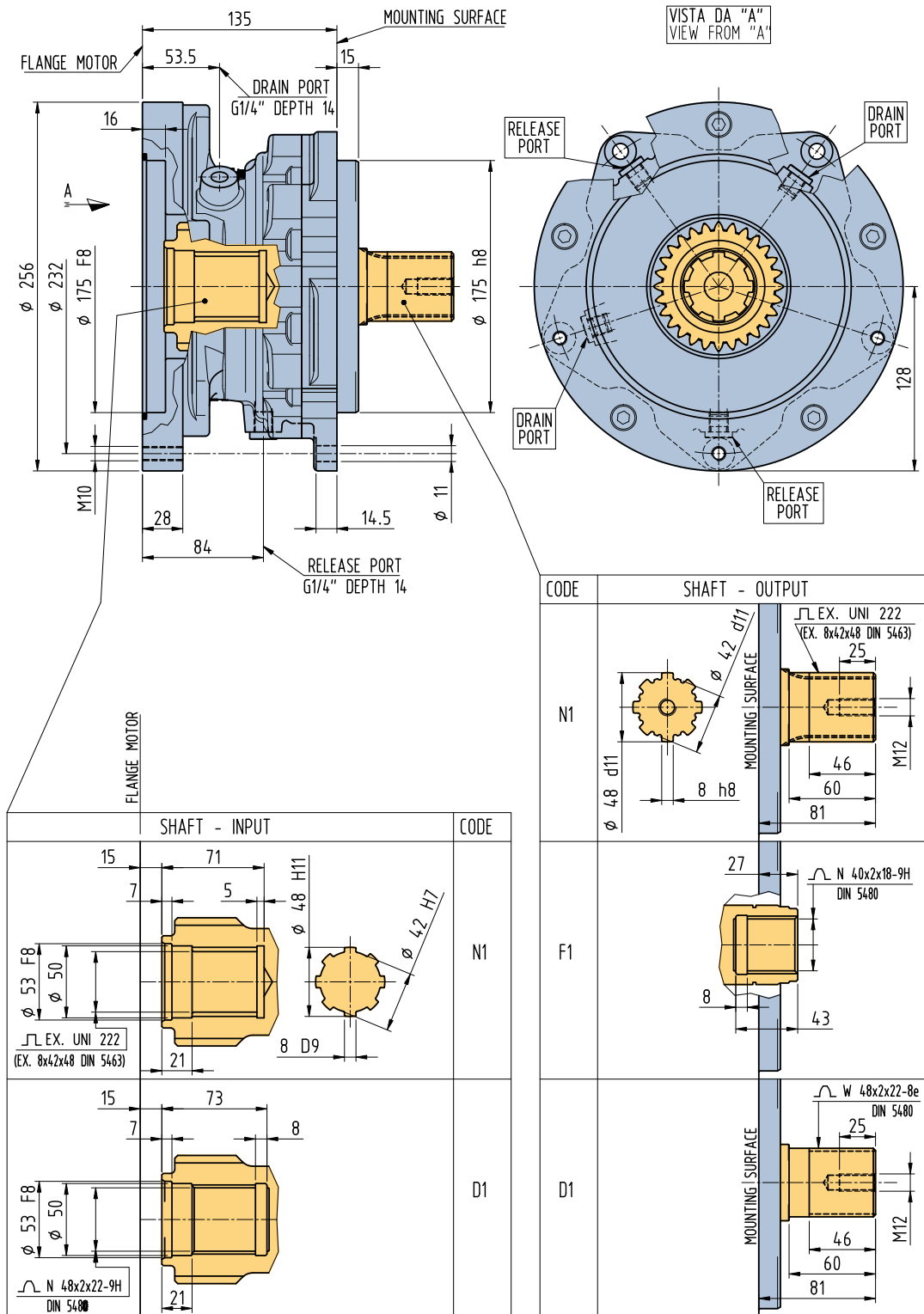

ORDERING INFORMATION

B300D	-			
BRAKE TYPE	-	SHAFT OUTPUT	SHAFT INPUT	SEAL TYPE

CODE	SEAL TYPE
N1	NBR: mineral oil
V1	FPM seal

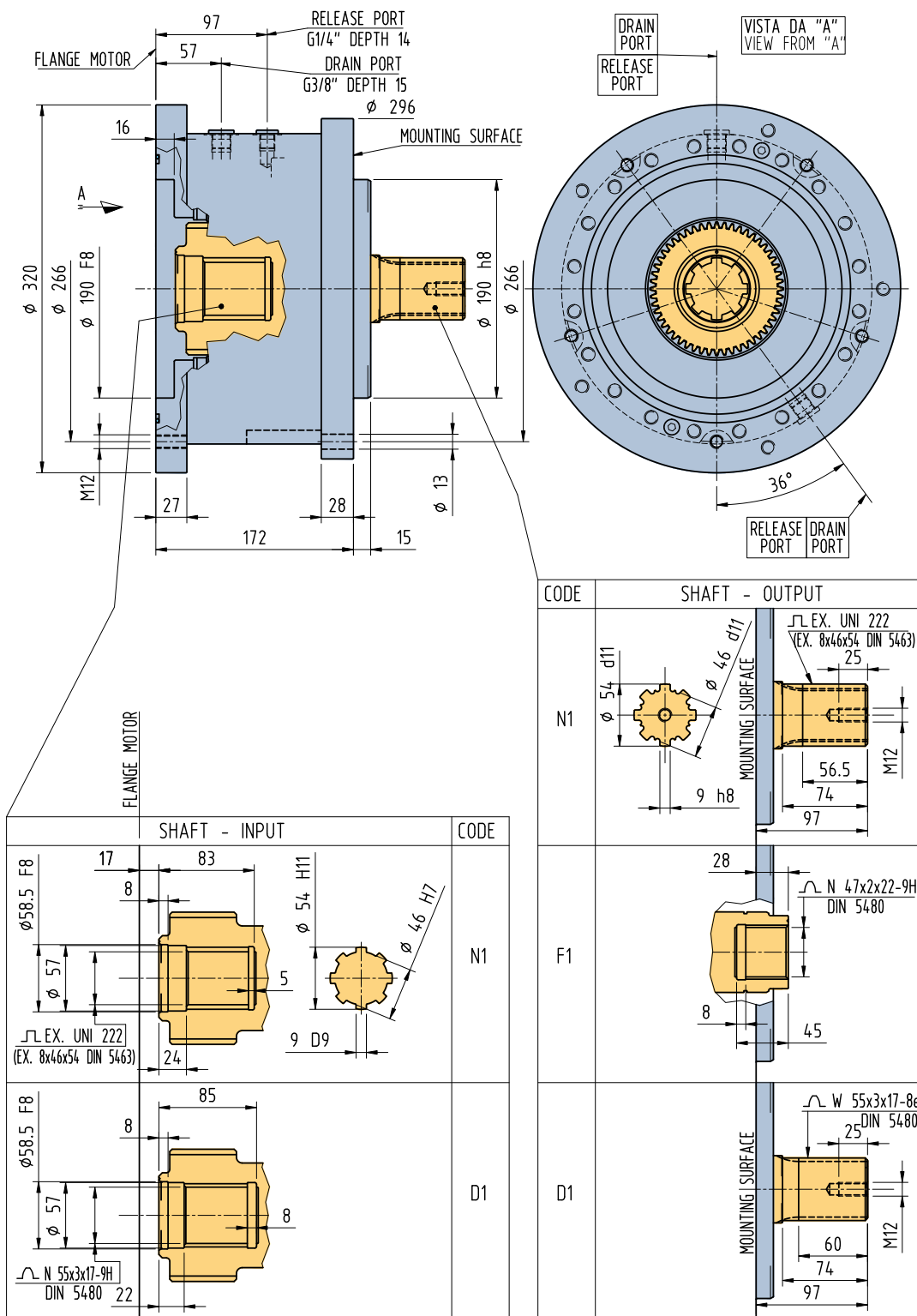

ORDERING INFORMATION

B450E	-			
BRAKE TYPE	-	SHAFT OUTPUT	SHAFT INPUT	SEAL TYPE

CODE	SEAL TYPE
N1	NBR: mineral oil
V1	FPM seal

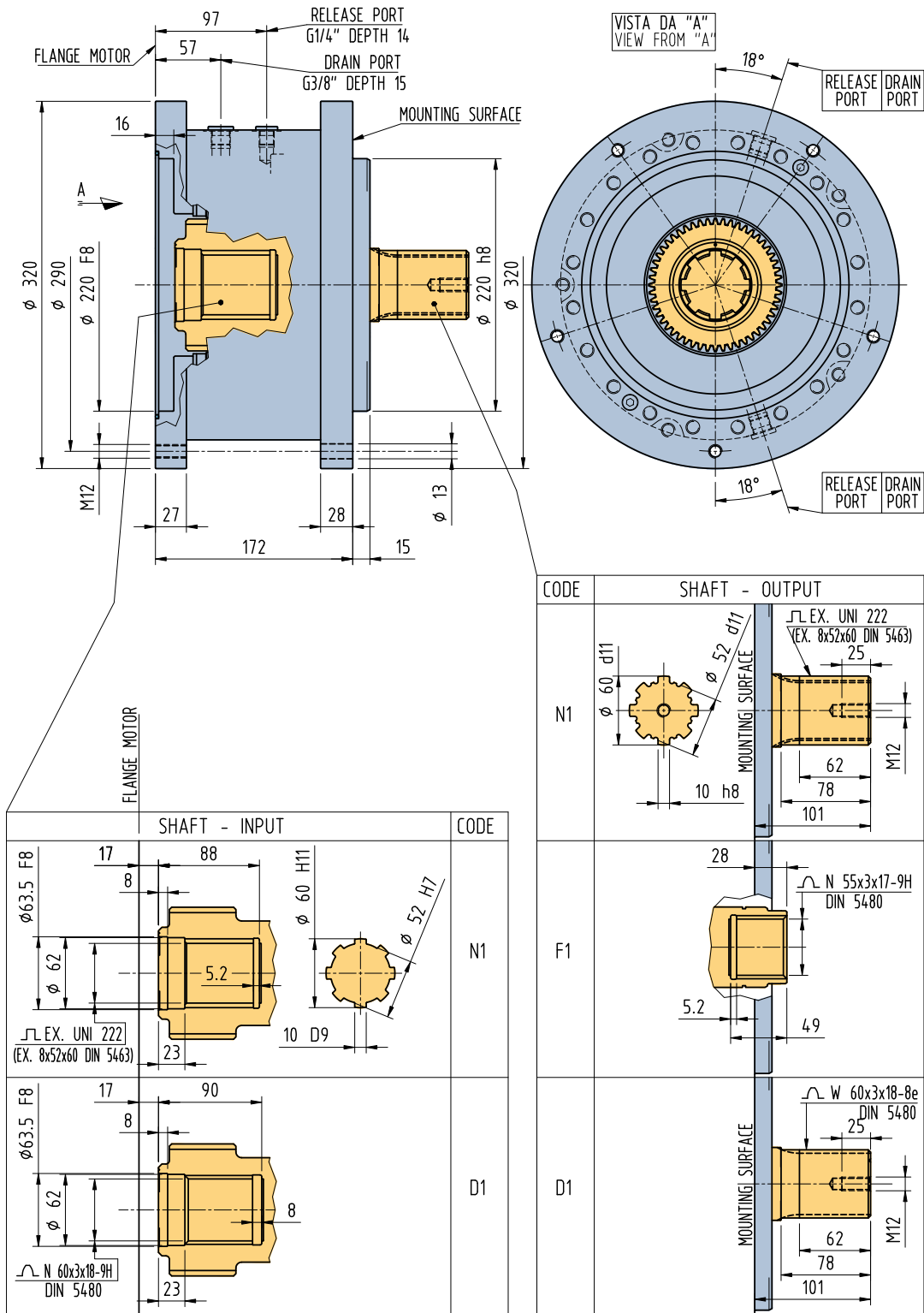

ORDERING INFORMATION

B700F	-			
BRAKE TYPE	-	SHAFT OUTPUT	SHAFT INPUT	SEAL TYPE

CODE	SEAL TYPE
N1	NBR: mineral oil
V1	FPM seal

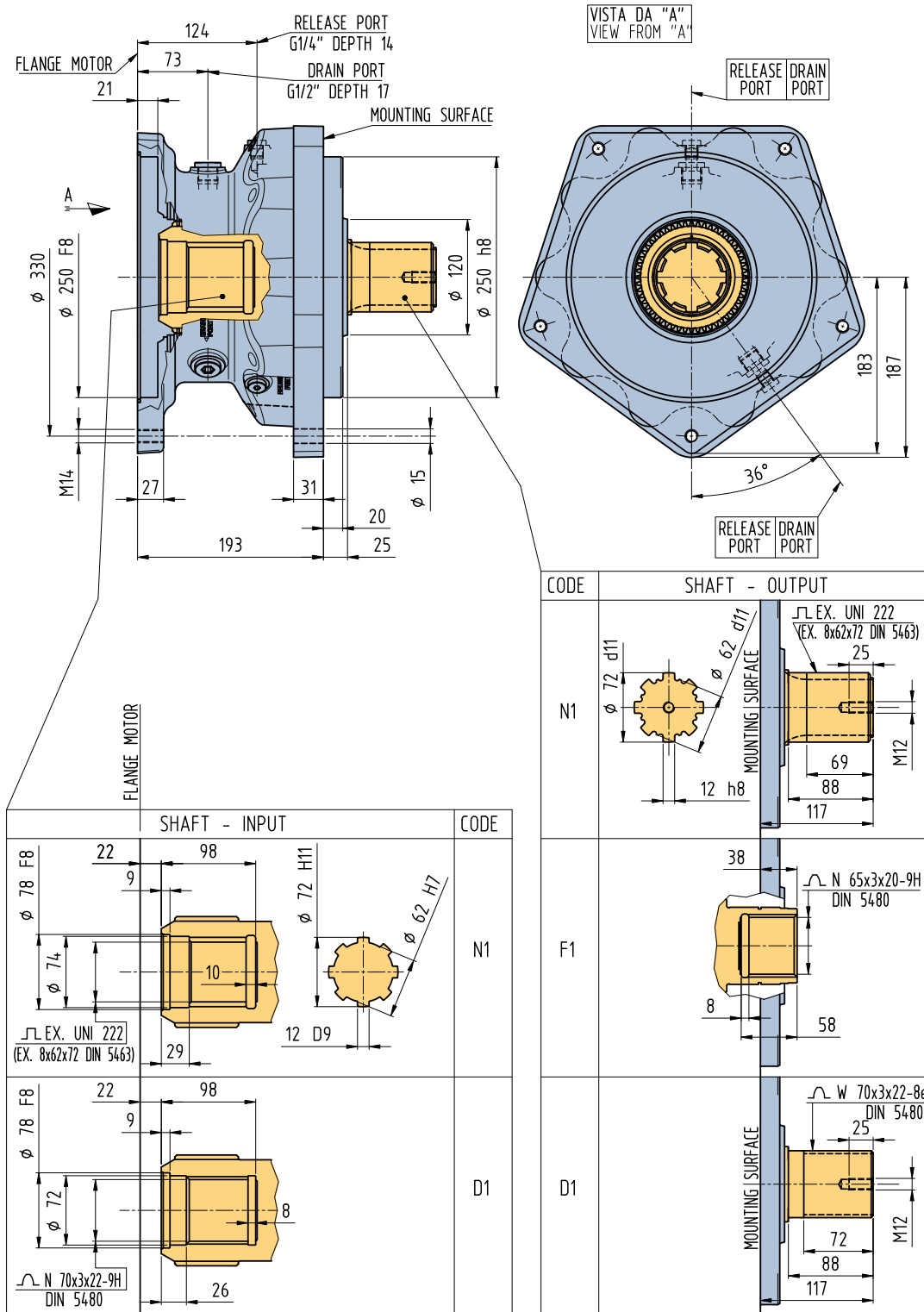

ORDERING INFORMATION

B1100G	-			
BRAKE TYPE	-	SHAFT OUTPUT	SHAFT INPUT	SEAL TYPE

CODE	SEAL TYPE
N1	NBR: mineral oil
V1	FPM seal

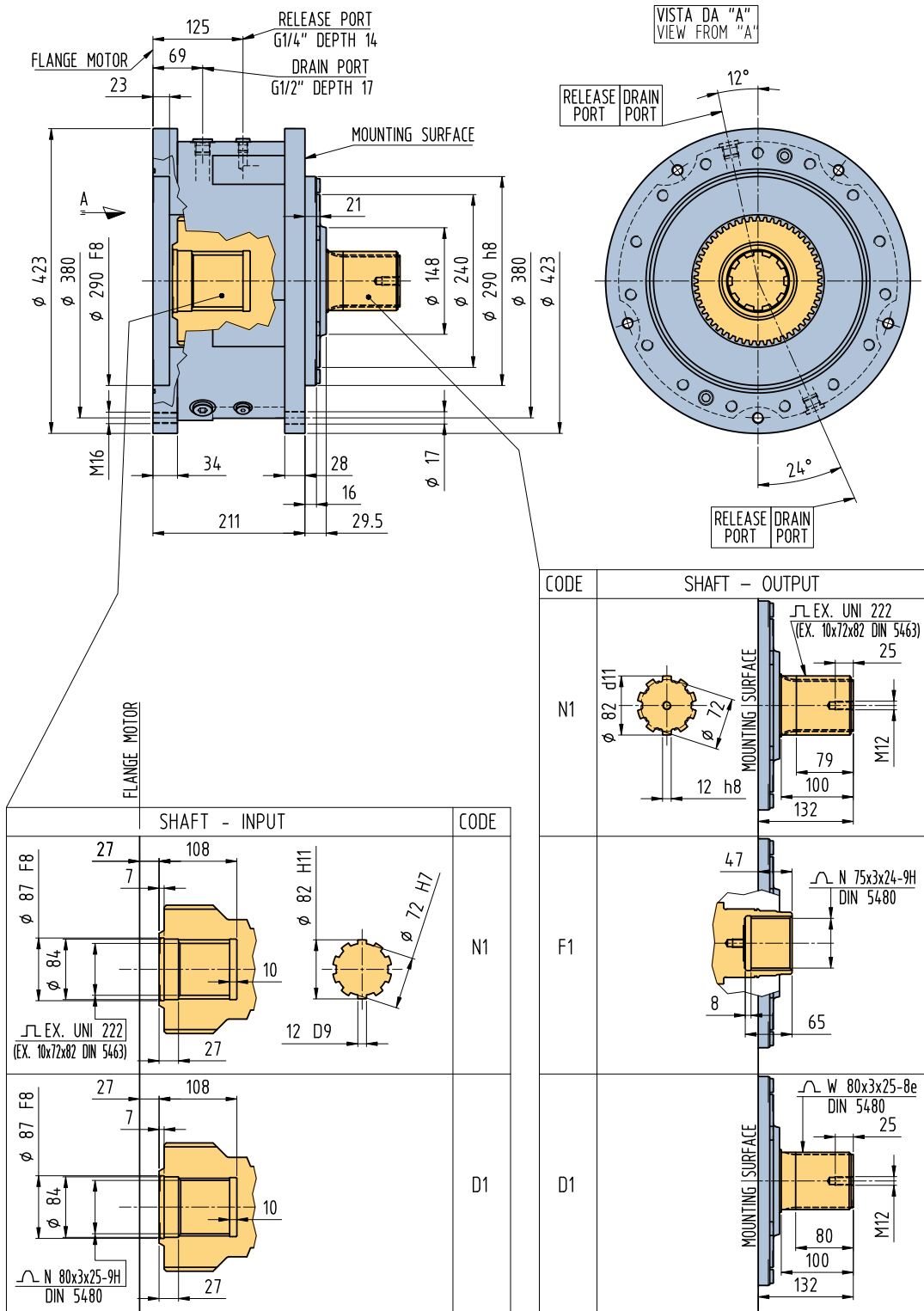

ORDERING INFORMATION

B1800H	-			
BRAKE TYPE	-	SHAFT OUTPUT	SHAFT INPUT	SEAL TYPE

CODE	SEAL TYPE
N1	NBR: mineral oil
V1	FPM seal

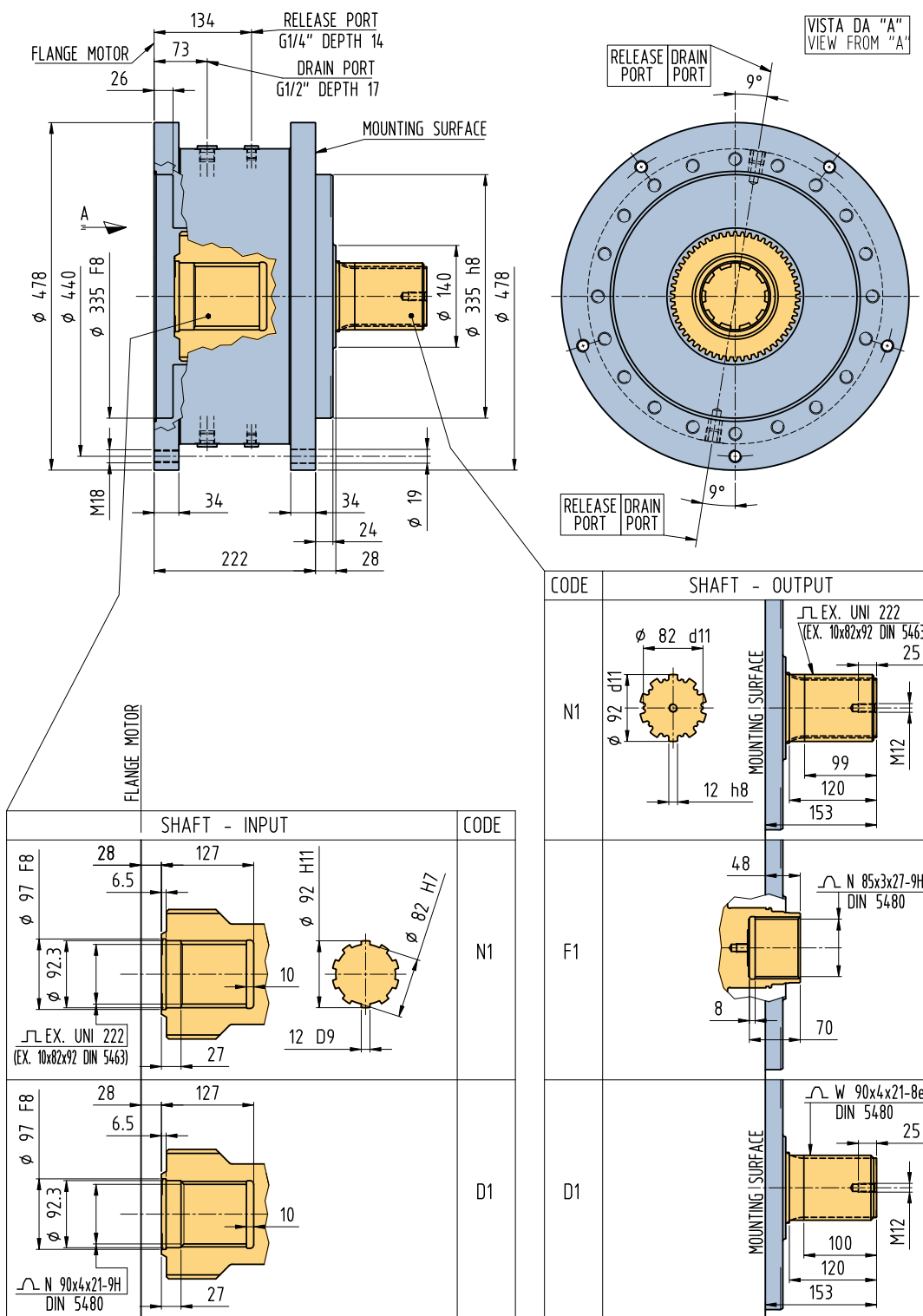

ORDERING INFORMATION

B2800I	-			
BRAKE TYPE	-	SHAFT OUTPUT	SHAFT INPUT	SEAL TYPE

CODE	SEAL TYPE
N1	NBR: mineral oil
V1	FPM seal

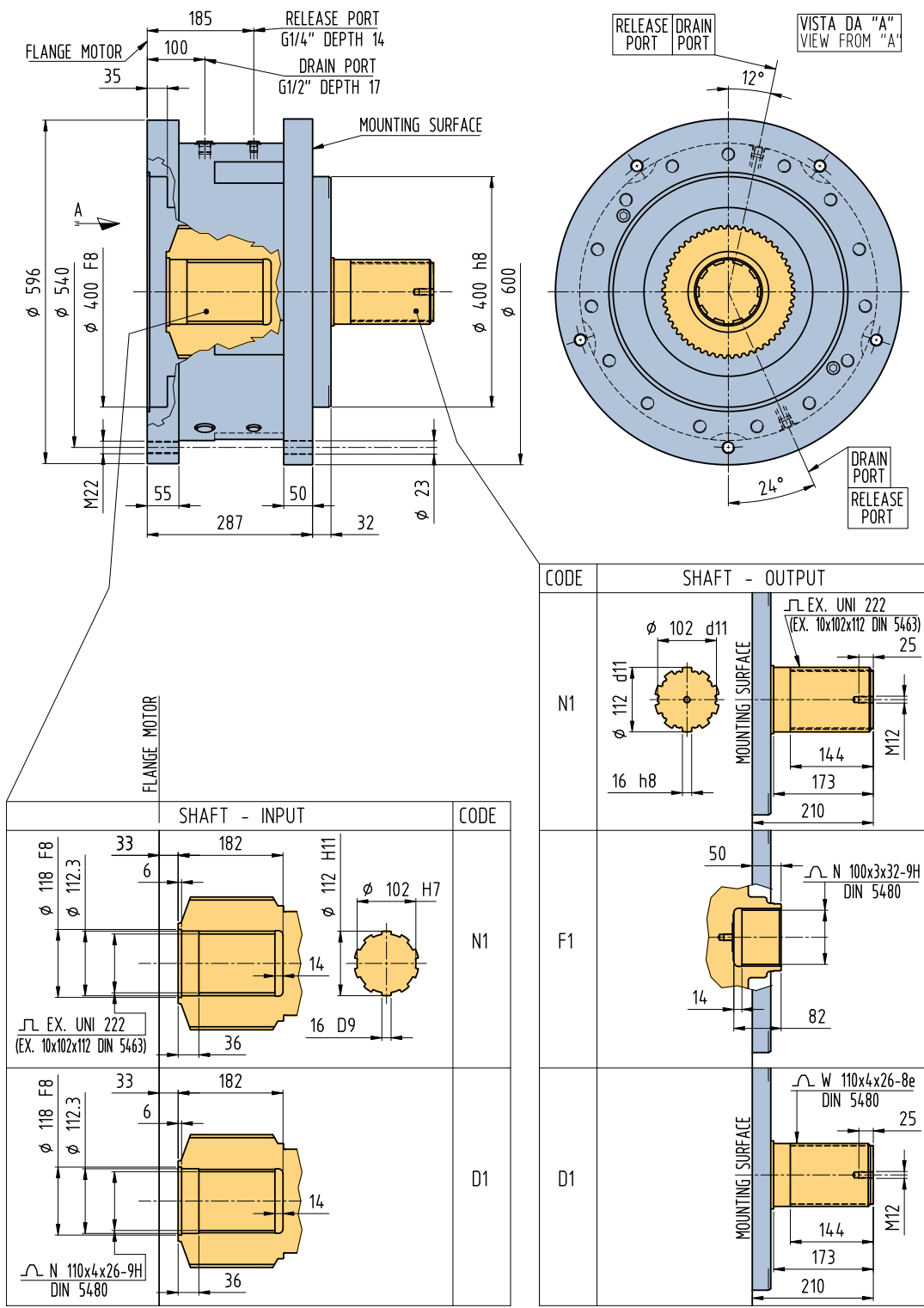

ORDERING INFORMATION

B4500L	-			
BRAKE TYPE	-	SHAFT OUTPUT	SHAFT INPUT	SEAL TYPE

CODE	SEAL TYPE
N1	NBR: mineral oil
V1	FPM seal

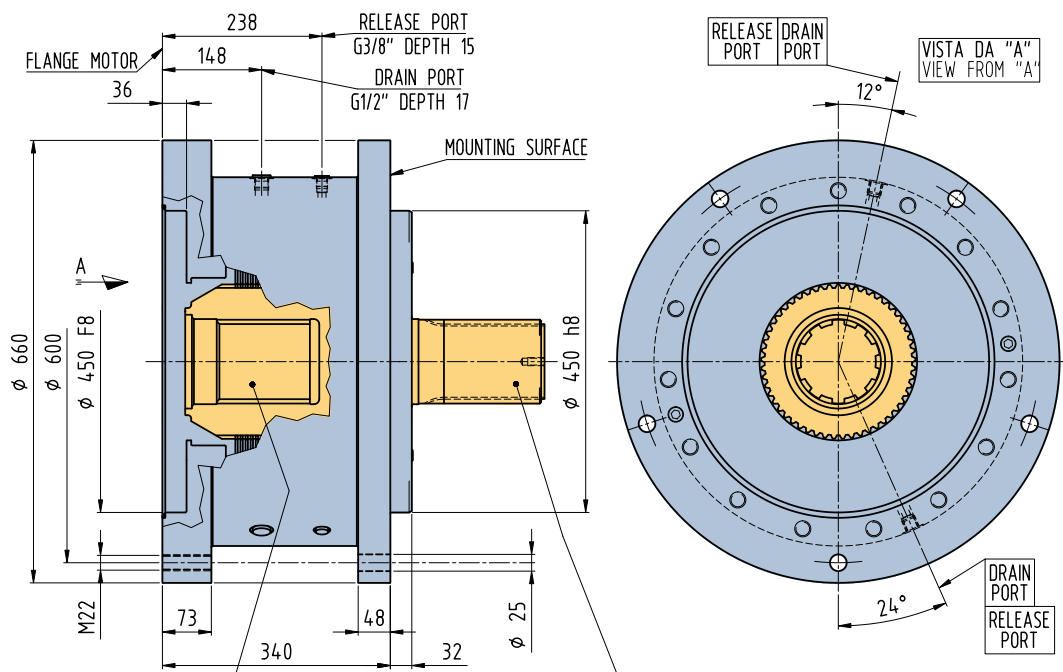

SHAFT - INPUT		CODE
<p>34 200 10 139.9 F8 127 14 18 D9 4.7 125 H11 112 H7</p> <p>EX. UNI 222 (EX. 10x112x125 DIN 5463)</p>	N1	
<p>34 200 10 139.9 F8 127 14 4.7 120x4x28-9H DIN 5480</p>	D1	

CODE	SHAFT - OUTPUT
N1	<p>EX. UNI 222 (EX. 10x112x125 DIN 5463)</p> <p>112 d11 25 150 188 230 125 d11 18 h8 14 18 25 M12</p>
F1	<p>50 14 90 N 110x3x35-9H DIN 5480</p>
D1	<p>W 120x4x28-8e DIN 5480</p> <p>153 188 230 25 M12</p>

ORDERING INFORMATION

B7000M	-			
BRAKE TYPE	-	SHAFT OUTPUT	SHAFT INPUT	SEAL TYPE

CODE	SEAL TYPE
N1	NBR: mineral oil
V1	FPM seal

Parking Brakes For Calzoni HTLS (radial) Piston Motors

CUSTOMIZATIONS

Brakes can be customized on customer request. Please consult Parker Hannifin for different mounting flanges and shaft dimensions, high radial and axial load capacity, and configuration not included in this catalogue.

In the pictures below some example solutions for customer requests with customized brakes are shown.

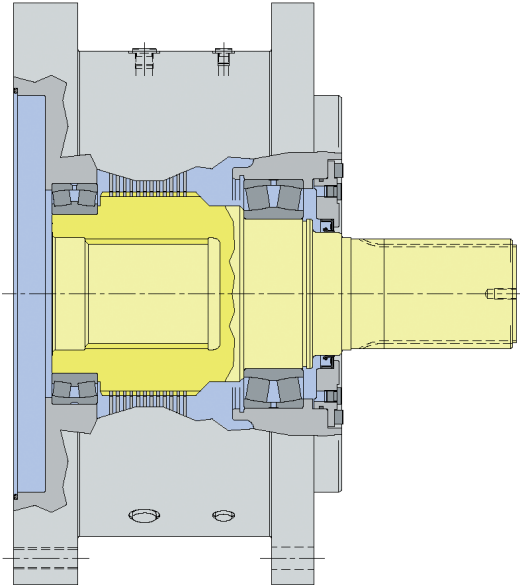

Brake with high capacity bearings for radial load support.

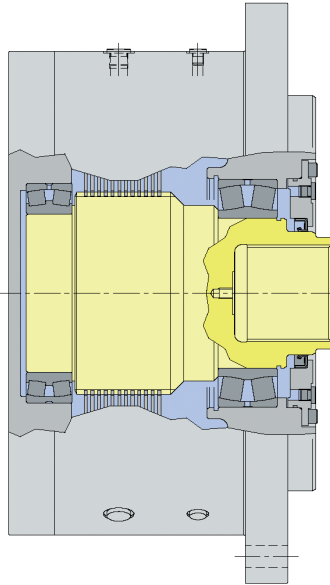

Brake with high capacity bearings for radial load support and only one spline.

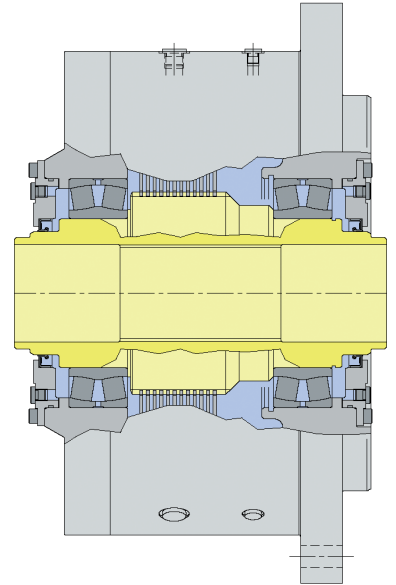

Brake with high capacity bearings for radial load support and through shaft.

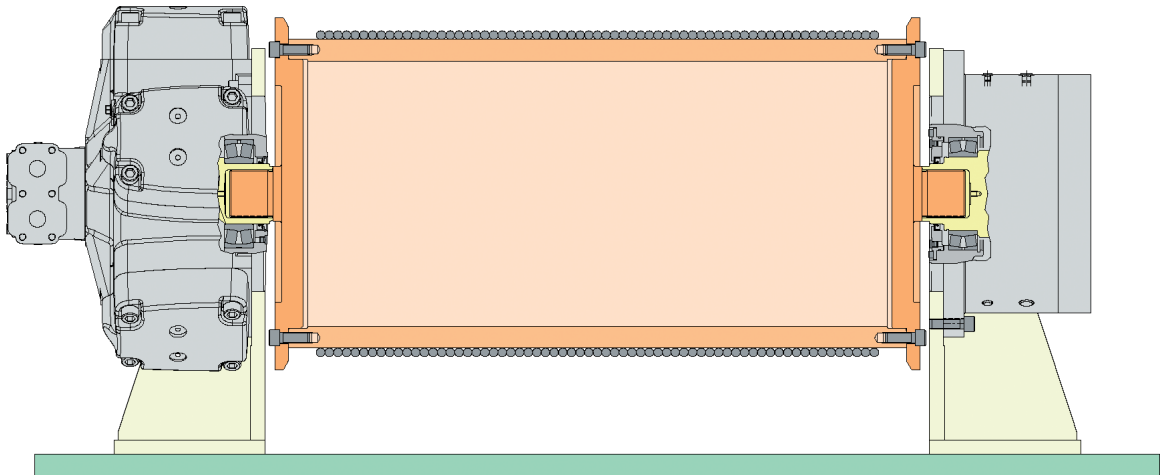

Direct mounted winch drum drive and brake (high capacity bearings for radial load support).

Parker Worldwide

AE – UAE, Dubai
Tel: +971 4 8127100
parker.me@parker.com

AR – Argentina, Buenos Aires
Tel: +54 3327 44 4129

AT – Austria, Wiener Neustadt
Tel: +43 (0)2622 23501-0
parker.austria@parker.com

AT – Eastern Europe, Wiener Neustadt
Tel: +43 (0)2622 23501 900
parker.easteurope@parker.com

AU – Australia, Castle Hill
Tel: +61 (0)2-9634 7777

AZ – Azerbaijan, Baku
Tel: +994 50 2233 458
parker.azerbaijan@parker.com

BE/LU – Belgium, Nivelles
Tel: +32 (0)67 280 900
parker.belgium@parker.com

BR – Brazil, Cachoeirinha RS
Tel: +55 51 3470 9144

BY – Belarus, Minsk
Tel: +375 17 209 9399
parker.belarus@parker.com

CA – Canada, Milton, Ontario
Tel: +1 905 693 3000

CH – Switzerland, Etoy
Tel: +41 (0) 21 821 02 30
parker.switzerland@parker.com

CL – Chile, Santiago
Tel: +56 2 623 1216

CN – China, Shanghai
Tel: +86 21 5031 2525

CZ – Czech Republic, Klecany
Tel: +420 284 083 111
parker.czechrepublic@parker.com

DE – Germany, Kaarst
Tel: +49 (0)2131 4016 0
parker.germany@parker.com

DK – Denmark, Ballerup
Tel: +45 43 56 04 00
parker.denmark@parker.com

ES – Spain, Madrid
Tel: +34 902 33 00 01
parker.spain@parker.com

FI – Finland, Vantaa
Tel: +358 (0)20 753 2500
parker.finland@parker.com

FR – France, Contamine s/Arve
Tel: +33 (0)4 50 25 80 25
parker.france@parker.com

GR – Greece, Athens
Tel: +30 210 933 6450
parker.greece@parker.com

HK – Hong Kong
Tel: +852 2428 8008

HU – Hungary, Budapest
Tel: +36 1 220 4155
parker.hungary@parker.com

IE – Ireland, Dublin
Tel: +353 (0)1 466 6370
parker.ireland@parker.com

IN – India, Mumbai
Tel: +91 22 6513 7081-85

IT – Italy, Corsico (MI)
Tel: +39 02 45 19 21
parker.italy@parker.com

JP – Japan, Fujisawa
Tel: +(81) 4 6635 3050

KR – South Korea, Seoul
Tel: +82 2 559 0400

KZ – Kazakhstan, Almaty
Tel: +7 7272 505 800
parker.easteurope@parker.com

LV – Latvia, Riga
Tel: +371 6 745 2601
parker.latvia@parker.com

MX – Mexico, Apodaca
Tel: +52 81 8156 6000

MY – Malaysia, Shah Alam
Tel: +60 3 7849 0800

NL – The Netherlands, Oldenzaal
Tel: +31 (0)541 585 000
parker.nl@parker.com

NO – Norway, Ski
Tel: +47 64 91 10 00
parker.norway@parker.com

NZ – New Zealand, Mt Wellington
Tel: +64 9 574 1744

PL – Poland, Warsaw
Tel: +48 (0)22 573 24 00
parker.poland@parker.com

PT – Portugal, Leca da Palmeira
Tel: +351 22 999 7360
parker.portugal@parker.com

RO – Romania, Bucharest
Tel: +40 21 252 1382
parker.romania@parker.com

RU – Russia, Moscow
Tel: +7 495 645-2156
parker.russia@parker.com

SE – Sweden, Spånga
Tel: +46 (0)8 59 79 50 00
parker.sweden@parker.com

SG – Singapore
Tel: +65 6887 6300

SK – Slovakia, Banská Bystrica
Tel: +421 484 162 252
parker.slovakia@parker.com

SL – Slovenia, Novo Mesto
Tel: +386 7 337 6650
parker.slovenia@parker.com

TH – Thailand, Bangkok
Tel: +662 717 8140

TR – Turkey, Istanbul
Tel: +90 216 4997081
parker.turkey@parker.com

TW – Taiwan, Taipei
Tel: +886 2 2298 8987

UA – Ukraine, Kiev
Tel: +380 44 494 2731
parker.ukraine@parker.com

UK – United Kingdom, Warwick
Tel: +44 (0)1926 317 878
parker.uk@parker.com

US – USA, Cleveland (industrial)
Tel: +1 216 896 3000

US – USA, Lincolnshire (mobile)
Tel: +1 847 821 1500

VE – Venezuela, Caracas
Tel: +58 212 238 5422

ZA – South Africa, Kempton Park
Tel: +27 (0)11 961 0700
parker.southafrica@parker.com

European Product Information Centre
Free phone: 00 800 27 27 5374
(from AT, BE, CH, CZ, DE, DK, ES, FI, FR, IE, IT, NL, NO, PL, PT, RU, SE, UK, ZA)



Parker Hannifin spa
Vane Pump Division / Calzoni Plant
Via Caduti di Sabbiano 15/17
40011 Anzola dell'Emilia (Bologna)
Italy
Tel.: +39 051 6501611
Fax: +39 051 736221
www.parker.com