



aerospace
climate control
electromechanical
filtration
fluid & gas handling
hydraulics
pneumatics
process control
sealing & shielding



Heavy Duty Hydraulic Roundline Cylinders

Series RDH



ENGINEERING YOUR SUCCESS.

In line with our policy of continuing product improvement, specifications and information contained in this catalog are subject to change.

Copyright ©2011 by Parker Hannifin Corporation.
All rights reserved.

PRINTED IN THE U.S.A.

 **WARNING**

FAILURE OR IMPROPER SELECTION OR IMPROPER USE OF THE PRODUCTS AND/OR SYSTEMS DESCRIBED HEREIN OR RELATED ITEMS CAN CAUSE DEATH, PERSONAL INJURY AND PROPERTY DAMAGE.

This document and other information from the Parker Hannifin Corporation, its subsidiaries and authorized distributors provide product and/or system options for further investigation by users having expertise. It is important that you analyze all aspects of your application, including consequences of any failure and review the information concerning the product or system in the current product catalog. Due to the variety of operating conditions and applications for these products or systems, the user, through its own analysis and testing, is solely responsible for making the final selection of the products and systems and assuring that all performance, safety and warning requirements of the application are met.

The products described herein, including without limitation, product features, specifications, designs, availability and pricing, are subject to change by Parker Hannifin Corporation and its subsidiaries at any time without notice.

Offer of Sale

The items described in this document are hereby offered for sale by Parker Hannifin Corporation, its subsidiaries or its authorized distributors. This offer and its acceptance are governed by provisions stated on a separate page of the document entitled 'Offer of Sale'.

Miller Fluid Power, manufacturer of the world's most diverse selection of hydraulic and pneumatic cylinders, is the single source of fluid power linear actuators for today's industrial markets.



Here is a short list of what you can expect from Miller Fluid Power:

- Design and Application Experience
- Responsiveness
- Fast Product Delivery
- System Integration Capabilities
- Ingenuity and Creativity
- Organizational Integrity
- Highest Quality
- Competitive Pricing
- Financial Stability
- Worldwide Support



Miller Fluid Power continues to work on new innovations. Whether it's the latest in cylinders for the mold industry or new materials of construction for improved cylinder life in demanding applications, contact Miller Fluid Power for your cylinder requirements.



Markets and Applications

Miller Fluid Power cylinders are utilized worldwide in many markets and applications, including:

- Oil and Gas
- Renewable Energy
- Power Generation
- Process Valves
- Mining
- Primary Metals
- Metal Fabrication
- Marine
- Civil Engineering Projects (including US Army Corps of Engineers Projects)
- Military and Commercial Aerospace
- Material Handling
- Testing and Analysis
- Construction
- Wood Processing
- Waste Processing
- Automotive
- Tire Press
- Machine Tools
- Entertainment

Miller Fluid Power Series RDH Cylinders

Advanced Sealing Technology

All components are manufactured and designed for high performance, long service life, low friction and zero leakage.

- **Tri-lip rod seal** (3 sealing edges!) and bi-directional piston seal feature proven leak-free performance.
- **Durable polyurethane** material is used to maximize seal life.
- **Nitrile end seals** and backup rings on a smooth bore of the cylinder body for optimal sealing and elimination of extrusion problems.
- **Composite rod and piston wear rings** are internally lubricated for reduced friction and formulated for heavy-duty, load-bearing applications.
- **Standard rod material is case-hardened, hard chrome plated and polished** to an optimum finish.
- And since we make our own seals, **all seals have immediate availability** in other popular compounds.

Switch-Ready

- **The ALS Switch is the lowest cost point feedback solution** for carbon steel cylinders.
- **Switches can be located anywhere along the stroke** and in any orientation.
- **Unique round body brackets** minimize installation time.
- **Switch-Ready (with magnetic ring)** available as a standard option.

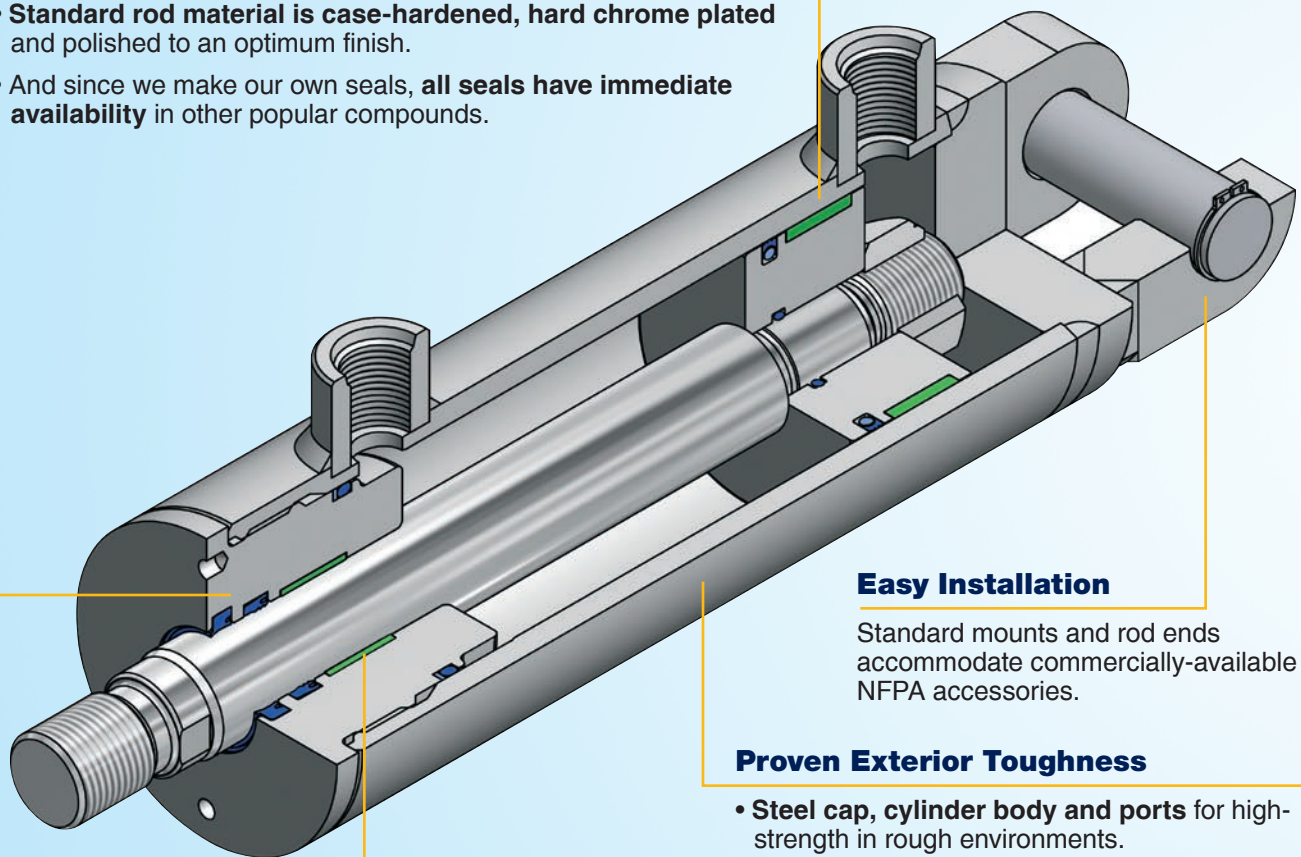

Composite Wear Rings

WearGard™ bearing materials are backed by over 30 years of manufacturing expertise.

- Heat stabilized and internally lubricated for **low friction and maximum service life** in any application.
- Strength characteristics meet or exceed most metals traditionally used in wear rings.

Easy Installation

Standard mounts and rod ends accommodate commercially-available NFPA accessories.

Proven Exterior Toughness

- **Steel cap, cylinder body and ports** for high-strength in rough environments.
- **Case hardened, hard chrome plated and polished carbon steel piston rod** for damage resistance, long rod seal life and low friction.
- **Outboard urethane rod wiper seal** to remove external debris and adherents from the piston rod.
- **High quality paint coating** for interior or exterior applications.



Environmentally Friendly
RoHS-compliant materials



Safety

Industrial-grade design factors for rod buckling, burst pressure and calm nerves.

New Value from a Standard Platform

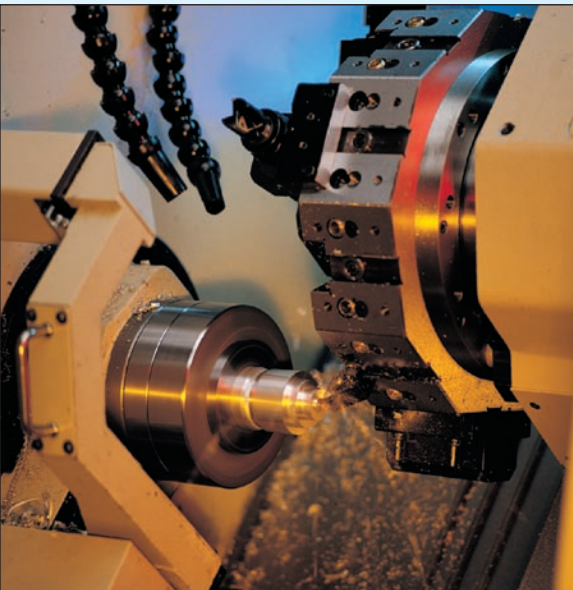

Advanced Manufacturing

Cylinders, by nature, are customized products. Whether it is something basic, such as stroke length, or something more complex, such as a special head, raw material and basic parts must be procured and manufactured into components for configured cylinders.

Organizing cylinder production and assembly requires some degree of planning. To do so, without sacrificing customer service, requires a sharp focus on advanced manufacturing processes.

Lean Manufacturing Principles

Miller Fluid Power has utilized Lean Manufacturing techniques for many years, even before it was called by name. Cellular Manufacturing, Value Stream Mapping, Kaizen events, Kanban, One-Piece Flow and other influences are pervasive in our manufacturing processes.

We now follow Lean Implementation to focus all aspects of our operation on the same goals for customer service.

Made in U.S.A.

Series RDH cylinders are manufactured in the USA. Location is a significant part of our customer service model. We believe that customers value a domestic presence, for many reasons. A few include:

- **Quick Delivery** – standard lead time is a few days, with the capability of shipping some cylinder configurations within 24 hours. We deliver to your request.
- **Made-To-Order** – we are able to quickly manufacture customized products without the need to carry fixed finished goods inventory. This minimizes time-to-customer and cost-to-customer concerns.

- **Late-Day Orders** – our West Coast presence can create an order time advantage of up to three hours for many US locations, which may be instrumental in keeping you on schedule.
- **Risk Management** – the absence of international risks from dealing with non-domestic cylinder suppliers will allow you to relax. Our goal is to offer you the best product, on time, with your financial concerns in mind.

- **Non-Standard Designs** – since 50% of applications require cylinders that are not catalog-standard, we organized our entire culture for flexibility. Our manufacturing processes are prepared to accommodate non-standard designs with minimal lead-time adjustments.



Customer Service Locations



Atlanta, GA



Enfield, CT



Corona, CA



Plymouth, MI



Goodland, IN

California
 221 Helicopter Circle
 Corona, CA 92880
 Tel.: (951) 280-3800
 Fax: (951) 280-3808
 Fax: (800) 869-9886

Indiana
 Goodland Plant
 715 South Iroquois Street
 Goodland, IN 47948
 Tel.: (219) 297-3182
 Fax: (800) 328-8120

Connecticut
 80 Shaker Road
 Enfield, CT 06082
 Tel.: (860) 749-2215
 Fax: (800) 323-0105

Michigan
 900 Plymouth Road
 Plymouth, MI 48170
 Tel.: (734) 455-1700
 Fax: (734) 455-1007

Georgia
 1300 Six Flags Road
 Lithia Springs, GA 30122
 Tel.: (770) 819-3400
 Fax: (800) 437-3498

Oregon
 29289 Airport Road
 Eugene, OR 97402
 Tel.: (541) 689-9111
 Fax: (541) 688-6771
 Fax: (800) 624-7996



Eugene, OR

Table of Contents

<i>Description</i>	<i>Page</i>	<i>Section</i>
Section A – Basic Cylinder Information	2-20	A
Product Specifications	2	
Available Mounting Styles	3	
Custom Options and Modifications	3	
Features and Benefits	4-5	
Application Checklist	6	
Mounting Styles and Tips for Applying	7	
How To Order (Series RDH Cylinder Model Code)	8-9	
Rod End Styles and Dimensions	10	
Mounting Information for Single Rod Cylinders	11-19	
Mounting Information for Double Rod Cylinders	20	
Section B – Cylinder Accessories and Replacement Parts	21-29	B
Cylinder Mounting Accessories	21-27	
Spherical Bearing Mount Accessories	26	
Linear Alignment Couplers	27	
Style 55 Piston Rod End Accessories	28	
Parts Identification / Seal Kits / Service Tools	29	
Section C – Common Modifications	31-43	C
Water Submersible Option	31-32	
Hi Load Piston	33	
Low Friction Seals	34-35	
JP Mount (J Mount with Pilot)	35	
Other Common Modifications	36	
ALS Switch	37-40	
CLS-2 Limit Switch	41-43	
Section D – Engineering Data	45-55	D
Theoretical Push and Pull Forces	45	
Cylinder Weights	46	
Seal Information	47-48	
Ports	49	
Stroke Data and Tolerances	50	
Fatigue Life	50	
Mounting Groups and Force Transfer	50	
Stop Tubing	51	
Piston Rod Selection Data	52-53	
Cylinder Safety Guide	54-55	

General Specifications

- Heavy duty service
- Standard construction – threaded head, welded cap
- Bore diameters – 1.50" through 8.00"
- Strokes – available in any practical stroke length
- Piston rod diameters – 0.625" through 5.500"
(based on bore size)
- Rod end styles – 5 standard, specials available

- Single rod end or double rod ends
- Mounting styles – 9 standard styles at various application ratings
- Nominal pressure – 3,000 psi¹ (207 Bar)
- Standard fluid media – filtered hydraulic oil²
- Standard temperature – -10°F to +165°F³
- RoHS compliant

In line with our policy of continuing product improvement, specifications in this catalog are subject to change.

¹ If hydraulic pressure exceeds 3,000 psi (207 Bar), please send application data for engineering evaluation and recommendation.

² See pages 47-48 for appropriate seals with different fluid media.

³ See pages 47-48 for lower and higher temperature service.

Material Specifications – Standard Temperatures and Applications

Head	Ductile iron	Piston	Ductile iron
Cap	Carbon steel	Piston seal	Polyurethane
Cylinder body	Carbon steel	Piston seal energizer	Nitrile
Piston rod	Case-hardened, chrome plated high strength carbon steel	Piston bearing	WearGard™ or MolyGard™
Rod seal	Polyurethane	Piston fastener	Carbon steel
Rod wiper seal	Urethane	Piston joint o-ring	Fluorocarbon
Rod bearing	WearGard™	End seal o-ring	Nitrile
		Backup ring	Nitrile

Operating Temperature Options – Material and Part Changes

High temperatures (to +250°F) Class 5	Rod seal, rod wiper seal, end seal, backup ring and piston seal energizer are fluorocarbon. Piston seal is bronze filled PTFE.	Low temperatures (to -50°F) Class 4	Piston seal energizer, end seal and backup ring are low temperature rated nitrile.
Extreme high temperatures (to +400°F) Class 8	Rod seals, rod wiper seal and piston seal are bronze filled PTFE. End seal o-ring, backup ring and seal energizers are fluorocarbon. Bearings are UltraComp™ CGT.		

Other Standard Options – Material and Part Changes

Cylinder seal options ⁴ (for chemical compatibility)	Water Base Fluid Seals (Class 2) EPR Seals (Class 3) Fluorocarbon Seals (Class 5) HWCF Seals (Class 6) Mixed-Media Piston Seals (bronze filled PTFE and nitrile)	Magnetic ring	Sintered NdFeB
		Piston rod material options	17-4 PH stainless steel, chrome plated 303 and 316 stainless steel are available at lower operating pressures; please consult factory.

⁴ Please see pages 47-48 for additional information.

Private Labeling

For those discerning customers wanting a personal touch, we can “private label” cylinders at no charge. The information must be in text format (no logos) and the label must include our serial number and cylinder pressure rating. Just place an “S” for special in the Special Modification field and provide the private label information in the item notes. We take care of the rest!

If labels with logos are desired, please contact the Industrial Cylinder Division for assistance.

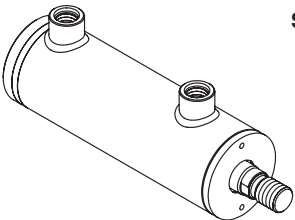
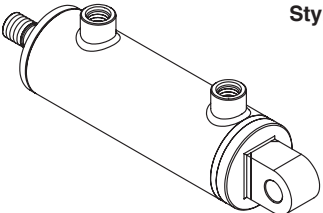
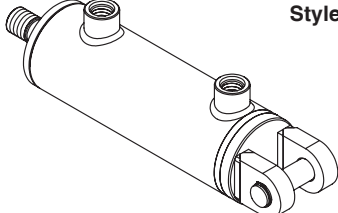
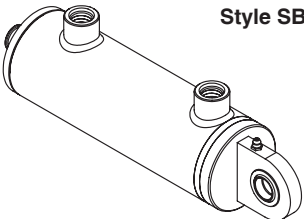
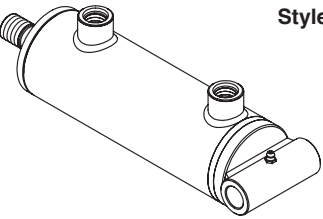
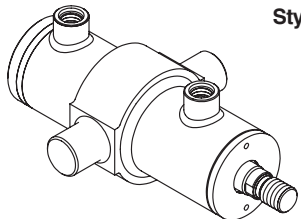
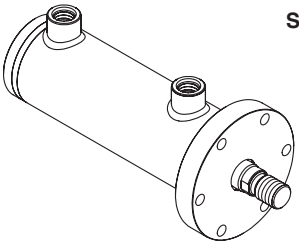
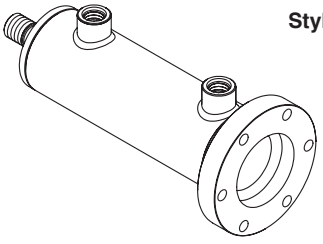
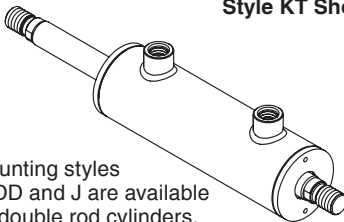

Available Mounting Styles

<p>Basic, No Mount Style T</p> 	<p>Cap Fixed Eye Style B</p> 	<p>Cap Fixed Clevis Style BB</p> 
<p>Spherical Bearing Cap End Style SB/SBM</p> 	<p>Crosstube Cap End Style TT</p> 	<p>Intermediate Fixed Trunnion Style DD</p> 
<p>Round Head Flange Style J</p> 	<p>Round Cap Flange Style H</p> 	<p>Double Rod Cylinders Style KT Shown</p>  <p>Mounting styles T, DD and J are available as double rod cylinders.</p>



Custom Options and Modifications (consult factory)

- Special Heads, Caps, Pistons and Mounts
- Mount/Port Relocation
- Oversize/Undersize Ports
- Port Thread Styles
- Port Blocks/Valve Manifold and Flow Tubing (at either end)
- Multiple Ports
- Cartridge Valves
- Air Bleeds
- Double Rod End
- Oversize/Undersize Rod Diameters
- Extra Thick Chrome Plated Piston Rod
- Rod Materials (stainless steels, alloy steels, etc.)
- Rod Coatings (laser-clad, nanoplating, etc.)
- Nitrided Rod
- Pinned Rod to Piston
- Welded Rod to Piston
- Welded Rod End Accessory
- Extra Wrench Flats
- Rod Boot
- Crown™ Wiper (Extreme Duty Non-Metallic Rod Wiper)
- Metallic Rod Wiper
- Seal Materials (additional compounds)
- PolyPak Seals
- Stop Tube
- Stroke Adjuster
- Point Feedback – ALS Switch (Solid-State PNP/NPN Mid-Stroke Switch)
- Point Feedback – CLS-2 Switch (Magnetically-Actuated End-Of-Stroke Limit Switch)
- Continuous Linear Position Feedback Linear Displacement Transducer (LDT)
- Fixed Cushions
- High Pressure Service (>3,000 PSI)
- Pneumatic Service
- Water Submersible Design
- Chrome Plated Bore
- Nickel Plated Assembly
- Application-Specific Paint (Marine-Grade, Salt-Spray Rated, Caustic Washdown, etc.)
- Stainless Steel Construction (derated operating pressure)
- Metric Rod and Bore Diameters
- Dual End Seals

The inside story on why Series RDH is your best choice in heavy duty roundline cylinders

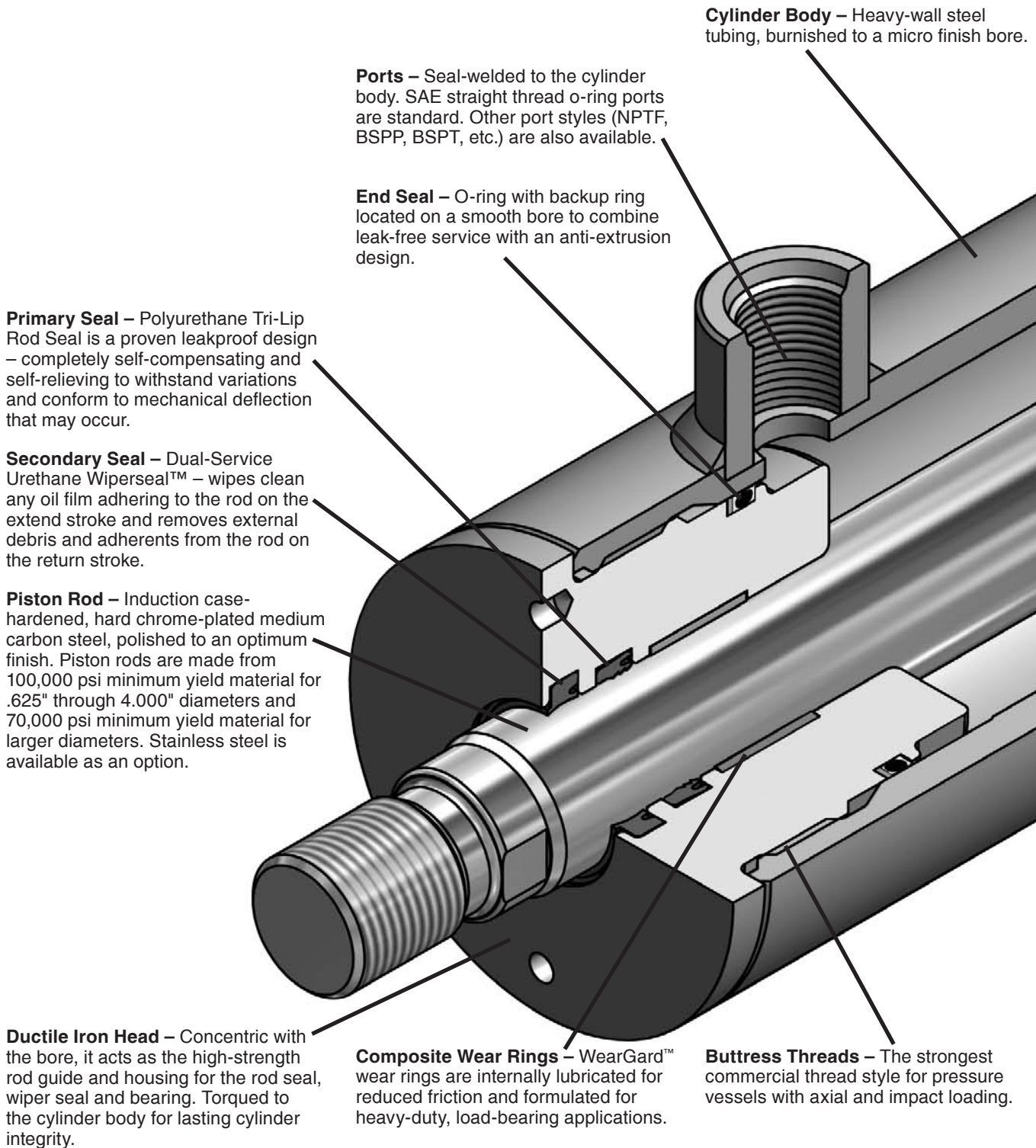

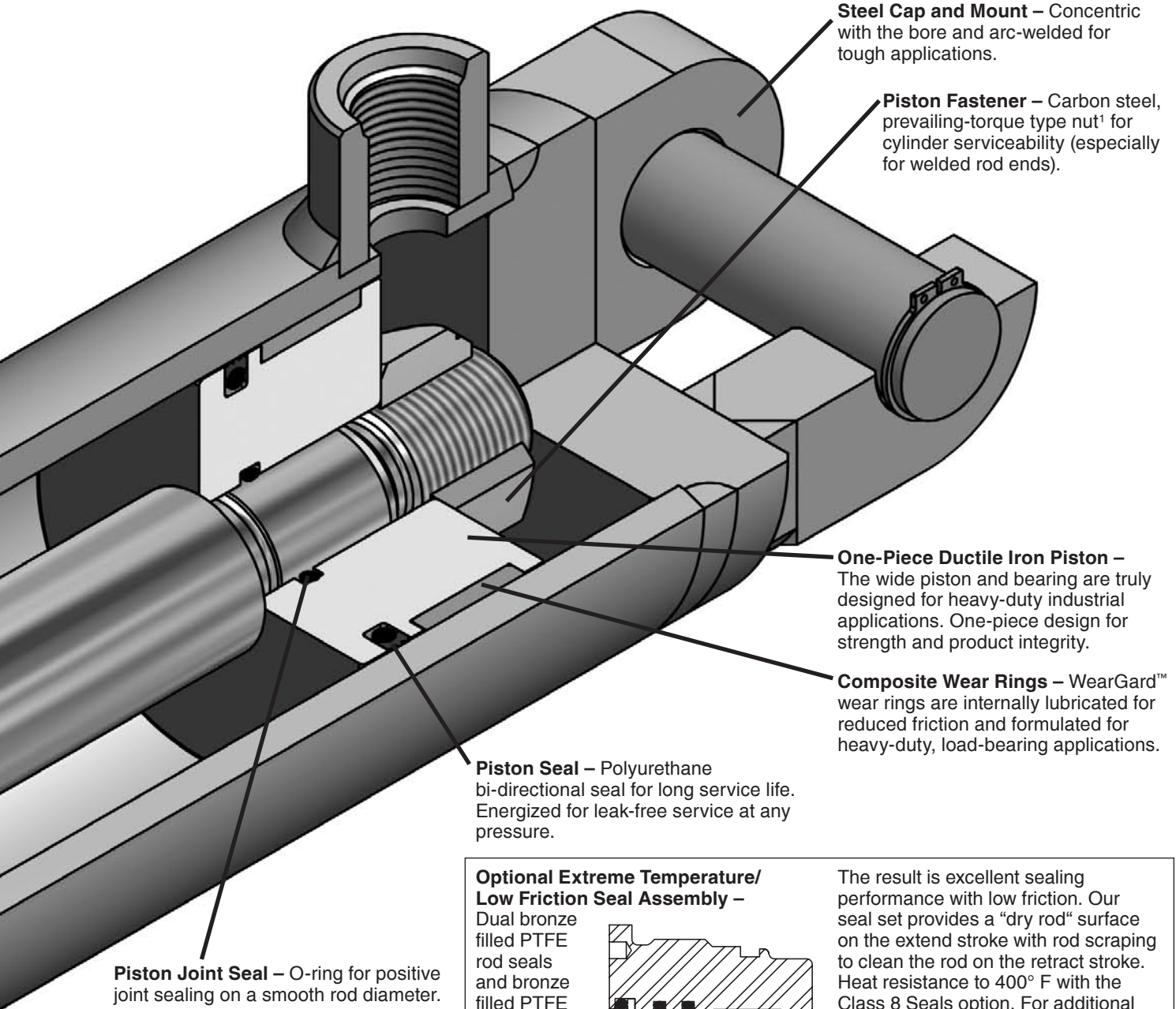

Steel Cap and Mount – Concentric with the bore and arc-welded for tough applications.

Piston Fastener – Carbon steel, prevailing-torque type nut¹ for cylinder serviceability (especially for welded rod ends).

One-Piece Ductile Iron Piston – The wide piston and bearing are truly designed for heavy-duty industrial applications. One-piece design for strength and product integrity.

Composite Wear Rings – WearGard™ wear rings are internally lubricated for reduced friction and formulated for heavy-duty, load-bearing applications.

Piston Seal – Polyurethane bi-directional seal for long service life. Energized for leak-free service at any pressure.

Piston Joint Seal – O-ring for positive joint sealing on a smooth rod diameter.

Optional Extreme Temperature/ Low Friction Seal Assembly –

Dual bronze filled PTFE rod seals and bronze filled PTFE wiper seal are energized with fluorocarbon o-rings to maintain consistent contact with the piston rod.

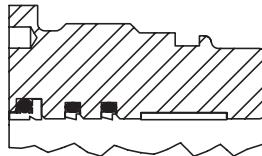

The result is excellent sealing performance with low friction. Our seal set provides a “dry rod” surface on the extend stroke with rod scraping to clean the rod on the retract stroke. Heat resistance to 400° F with the Class 8 Seals option. For additional details, please see the Low Friction information on pages 34-35 and Class 8 Seals specifications on page 47.

Optional Pistons

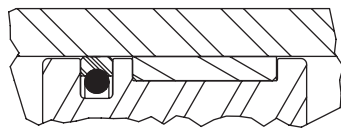

Hi Load/Low Friction Piston – Bronze filled PTFE piston seal for maximum seal life in extreme duty and side load applications.

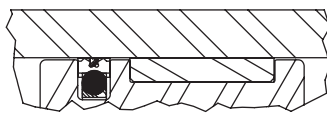

Mixed Media Piston – Used for dissimilar fluids or a gas on either side of the piston (i.e. air/oil applications).

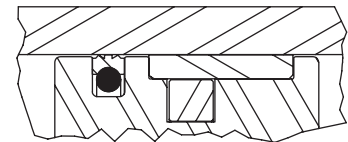

Magnetic Piston – Includes magnetic rings for the ALS Switch option.

¹ Only for 1.50" to 5.00" bores. For 6.00" to 8.00" bores, pistons are threaded and torqued to the piston rod, and set screws are used to lock the piston to the rod.



Application Checklist

The following checklist should be used to select the best possible cylinder for a given application. Additional information can be referenced in the following pages to help assist in this process. In the event that you have additional questions or concerns, or if more information is required, please contact your local distributor or our customer service representatives for assistance.

1. Establish the system requirements

- How heavy is the load to be moved?
- What is the nominal operating pressure of the system?
- How far does the load have to move?
- What is the speed at which the load will move?
- What is the fluid type and the temperature to which the cylinder will be exposed?

2. Mounting StylePages 3 and 7

- Determine the best mounting style for the application.

3. Cylinder Bore and Operating PressurePage 45

- Review the theoretical push and pull forces to determine the applicable bore and rod diameter sizes.

4. Piston RodPages 51-53

- Determine what rod size will be required to avoid buckling.
- Determine if a single or double rod cylinder is required.
- Determine the rod end style and rod end thread.
- Will stop tubing be required?
- Is adequate pull force still available or is a larger bore diameter now required?

5. SealsPages 47-48

- Select the proper seal type and configuration for the application.
- Select the proper seal to assure fluid and temperature compatibility.

6. PortsPage 49

- Select the best possible port size for a given speed requirement.
- Select port type.
- Select port position.

7. Piston rod and mounting accessoriesPages 21-28

- Determine how you will attach the cylinder to the load.

8. Optional accessories and modificationsPages 31-43

Mounting Styles and Tips for Applying Them

Pivot Mountings – B, BB, SB/SBM and TT

Application:

- Curved or arc line force transfer
- Can be used in compression or tension loads
- Movement in a simple arc – use B, BB or TT mounts
- Movement in a compound arc – use SB/SBM mount

Advantages:

- Ease of mounting
- Design flexibility
- Self aligning (SB/SBM mount)

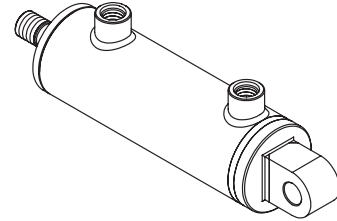

Trunnion Mountings – DD

Application:

- Curved or arc line force transfer
- Can be used in compression or tension loads

Advantages:

- Ease of mounting
- Design flexibility
- Improved cylinder weight support
- Reduces piston and rod bearing loads

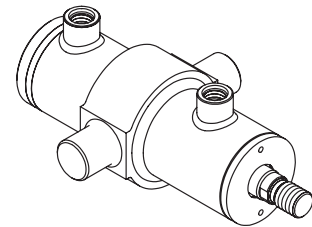

Flange Mountings – J and H

Application:

- Straight line force transfer
- Compression loads (push) – use H mount
- Tension loads (pull) – use J mount

Advantages:

- Ease of mounting
- Rigid base mounting due to large flange area

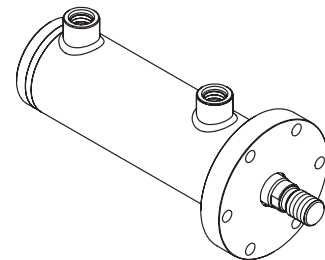

Series RDH Model Code

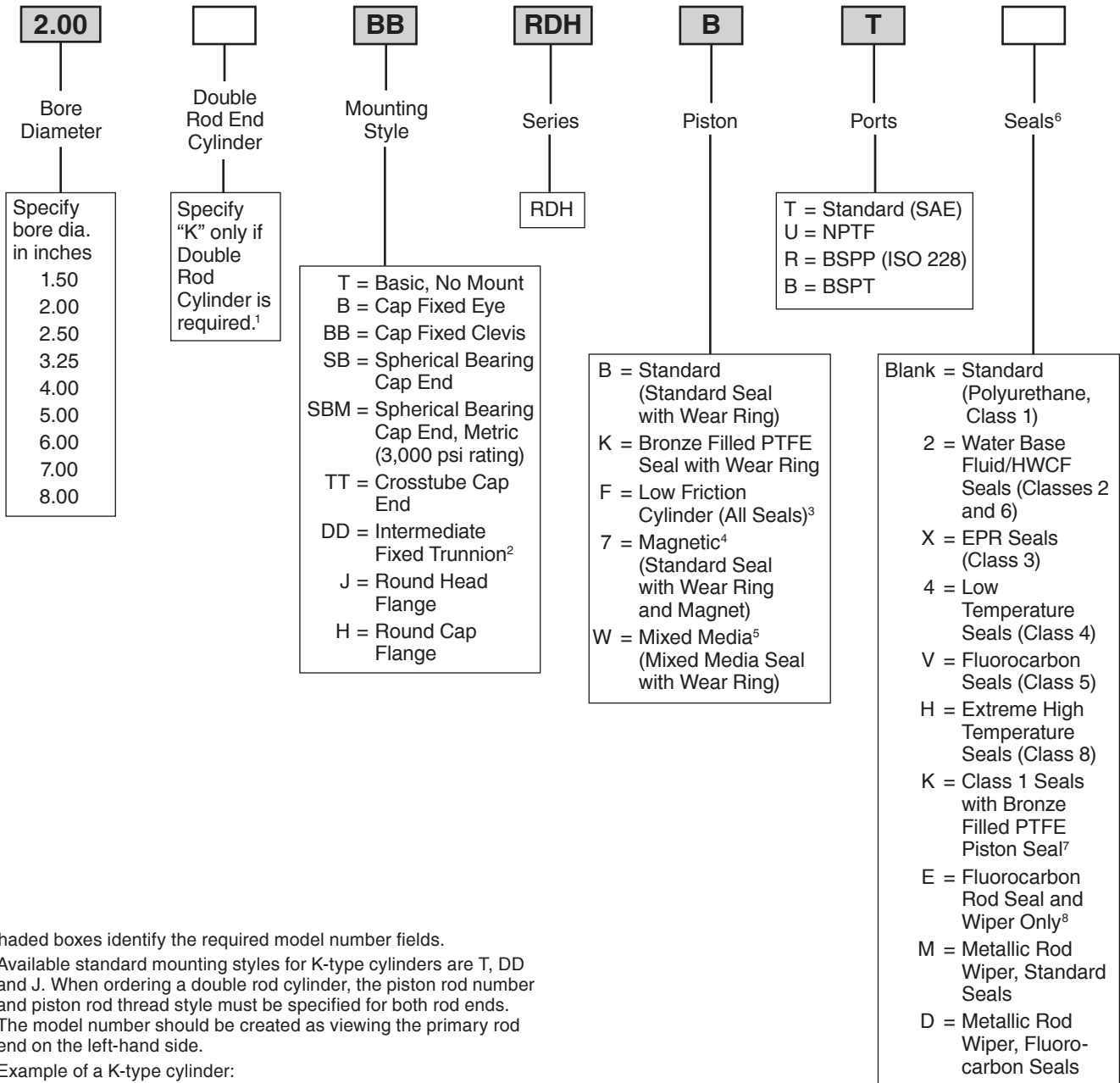

Shaded boxes identify the required model number fields.

¹ Available standard mounting styles for K-type cylinders are T, DD and J. When ordering a double rod cylinder, the piston rod number and piston rod thread style must be specified for both rod ends. The model number should be created as viewing the primary rod end on the left-hand side.

Example of a K-type cylinder:

4.00KDDRDHBT14A28A10.000

² Specify XI dimension. See minimum stroke on page 17.

³ Includes low friction seals for the entire cylinder. Available with standard seals and Seal codes 2, X, 4, V and H.

⁴ Used with externally mounted ALS Switches. Includes seal and wear ring from standard piston. Available for 1.50" to 6.00" bore diameters. Switch operating temperature range is -13°F to +185°F. Switch position may be restricted for Mounting Style DD. Please consult factory for other options.

⁵ Used for dissimilar fluids or a gas on either side of the piston (i.e. air/oil applications). Standard mixed media piston accommodates fluids which are compatible with Class 1 Seals (see pages 47-48). For other fluids, please consult factory.

⁶ Please see pages 47-48 for additional information.

⁷ Option used for Piston code 7 (Magnetic Piston).

⁸ Used for external chemical compatibility applications, not high temperature.

Series RDH Model Code

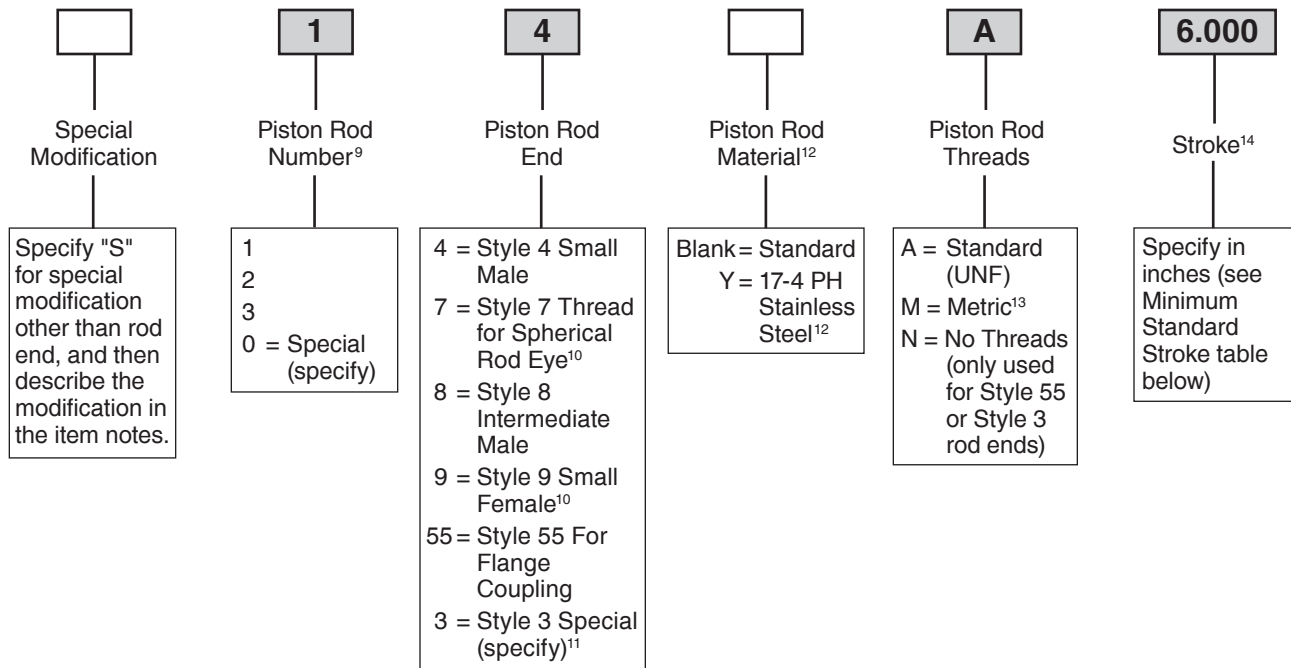

Minimum Standard Stroke

Bore Ø	Rod No.	With inline ports (same position)			With ports in different positions		
		All Male Rod Ends	Styles 7A and 9 Rod Ends		All Male Rod Ends	Styles 7A and 9 Rod Ends	
			J Mount	Other Mounts ¹⁵		J Mount	Other Mounts ¹⁵
1.50	1	2.690	2.690	2.690	0.000	0.000	0.000
	2	2.690	2.690	2.690	0.000	0.000	0.000
2.00	1	2.200	2.200	2.200	0.000	0.000	0.000
	2	2.200	2.200	2.200	0.000	0.000	0.500
2.50	1	2.250	2.250	2.250	0.000	0.000	0.000
	2	2.250	2.250	2.250	0.000	0.000	1.000
	3	2.250	2.250	2.250	0.000	0.000	0.500
3.25	1	2.320	2.320	2.320	0.000	0.000	0.000
	2	2.320	2.320	2.320	0.000	0.000	1.000
	3	2.320	2.320	2.320	0.000	0.000	0.500
4.00	1	1.880	1.880	1.880	0.000	0.000	0.000
	2	1.880	1.880	2.000	0.000	1.000	2.000
	3	1.880	1.880	1.880	0.000	0.000	0.750
5.00	1	1.820	1.820	1.820	0.000	0.000	0.500
	2	1.820	1.820	2.250	0.000	1.000	2.250
	3	1.820	1.820	1.820	0.000	0.000	1.500
6.00	1	1.750	1.750	1.750	0.000	0.000	1.500
	2	1.750	1.750	3.000	0.000	1.500	3.000
	3	1.750	1.750	2.000	0.000	0.500	2.000
7.00	1	2.000	2.000	2.000	0.000	0.000	2.000
	2	2.000	2.000	4.000	0.000	2.000	4.000
	3	2.000	2.000	3.000	0.000	1.000	3.000
8.00	1	2.000	2.000	2.000	0.000	0.000	2.000
	2	2.000	3.000	5.000	0.000	3.000	5.000
	3	2.000	2.000	3.500	0.000	1.500	3.500

Shaded boxes identify the required model number fields.

⁹ Refer to the Stop Tubing and Piston Rod Selection Data on pages 51-53 to assure that the selected rod number will not buckle under load.

¹⁰ Style 7A (UNF threads) and Style 9 may require a minimum stroke. Please see Minimum Standard Stroke in table to the right for details.

¹¹ Provide desired dimensions for KK (or CC), A and W. If otherwise special, please supply a dimensioned sketch. Accessories welded to the rod end are available.

¹² Other stainless steels (i.e. 303, 316) are available with a derated maximum operating pressure; please consult factory.

¹³ For Style 7M, see page 15 for details. For Styles 4M, 8M and 9M, see page 36 for details.

¹⁴ If a stop tube is required, specify **gross stroke** (net stroke + stop tube length) in the model number field, then place an "S" for special in the Special Modification field and specify the stop tube length in the item notes. For stroke length tolerance, please see page 50.

¹⁵ Except for DD Mount. For minimum stroke with DD Mount, please see page 17.

Ports in the same position (inline) will require some minimum stroke amount per bore and rod number combination. Most of this minimum stroke can be reduced or eliminated if one port is relocated to a different position. For inline ports, shorter net/working strokes are available with the use of a stop tube; however, the overall length of the cylinder will increase. To achieve your desired net/working stroke that is less than the minimum shown, please see footnote 14 and specify the stop tube length as the minimum stroke per the table above. Gross stroke (designated in the model code) will be the combination of the stop tube length and desired net (working) stroke length. If shortest total cylinder length is required and a stop tube is unacceptable, please consult factory.

Rod End Dimensions

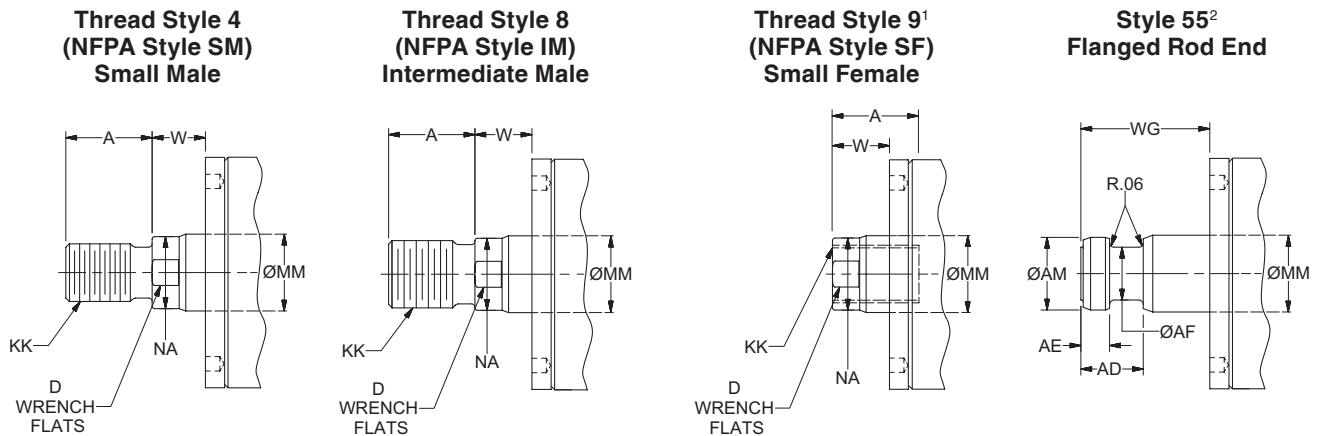

Rod End Dimensions

Bore Ø	Rod No.	MM Rod Ø	Thread		A	AD	AE +.001 -.001	AF Ø	AM Ø	D	NA	W	WG
			Style 8 CC	Style 4 & 9 KK									
1.50	1 (std)	0.625	1/2-20	7/16-20	0.75	0.63	0.249	0.38	0.57	0.50	0.56	0.56	1.13
	2	1.000	7/8-14	3/4-16	1.13	0.94	0.374	0.69	0.95	0.88	0.94	0.69	1.50
2.00	1 (std)	1.000	7/8-14	3/4-16	1.13	0.94	0.374	0.69	0.95	0.88	0.94	0.69	1.50
	2	1.375	1 1/4-12	1-14	1.63	1.06	0.374	0.88	1.32	1.13	1.31	0.81	1.75
2.50	1 (std)	1.000	7/8-14	3/4-16	1.13	0.94	0.374	0.69	0.95	0.88	0.94	0.69	1.50
	2	1.750	1 1/2-12	1 1/4-12	2.00	1.31	0.499	1.13	1.70	1.50	1.69	0.94	2.00
	3	1.375	1 1/4-12	1-14	1.63	1.06	0.374	0.88	1.32	1.13	1.31	0.81	1.75
3.25	1 (std)	1.375	1 1/4-12	1-14	1.63	1.06	0.374	0.88	1.32	1.13	1.31	0.81	1.75
	2	2.000	1 3/4-12	1 1/2-12	2.25	1.69	0.624	1.38	1.95	1.69	1.94	1.00	2.63
	3	1.750	1 1/2-12	1 1/4-12	2.00	1.31	0.499	1.13	1.70	1.50	1.69	0.94	2.00
4.00	1 (std)	1.750	1 1/2-12	1 1/4-12	2.00	1.31	0.499	1.13	1.70	1.50	1.69	0.94	2.00
	2	2.500	2 1/4-12	1 7/8-12	3.00	1.94	0.749	1.75	2.45	2.06	2.38	1.06	3.25
	3	2.000	1 3/4-12	1 1/2-12	2.25	1.69	0.624	1.38	1.95	1.69	1.94	1.00	2.63
5.00	1 (std)	2.000	1 3/4-12	1 1/2-12	2.25	1.69	0.624	1.38	1.95	1.69	1.94	1.00	2.63
	2	3.500	3 1/4-12	2 1/2-12	3.50	2.69	0.999	2.50	3.45	3.00	3.38	1.06	4.38
	3	2.500	2 1/4-12	1 7/8-12	3.00	1.94	0.749	1.75	2.45	2.06	2.38	1.06	3.25
6.00	1 (std)	2.500	2 1/4-12	1 7/8-12	3.00	1.94	0.749	1.75	2.45	2.06	2.38	1.06	3.25
	2	4.000	3 3/4-12	3-12	4.00	2.69	0.999	3.00	3.95	3.38	3.88	1.06	4.50
	3	3.000	2 3/4-12	2 1/4-12	3.50	2.44	0.874	2.25	2.95	2.63	2.88	1.06	3.63
7.00	1 (std)	3.000	2 3/4-12	2 1/4-12	3.50	2.44	0.874	2.25	2.95	2.63	2.88	1.06	3.63
	2	5.000	4 3/4-12	3 1/2-12	5.00	3.19	1.499	3.88	4.95	— ³	4.88	1.19	5.38
	3	4.000	3 3/4-12	3-12	4.00	2.69	0.999	3.00	3.95	3.38	3.88	1.06	4.50
8.00	1 (std)	3.500	3 1/4-12	2 1/2-12	3.50	2.69	0.999	2.50	3.45	3.00	3.38	1.06	4.38
	2	5.500	5 1/4-12	4-12	5.50	3.94	1.874	4.38	5.45	— ³	5.38	1.19	6.25
	3	4.500	4 1/4-12	3 1/4-12	4.50	3.19	1.499	3.50	4.45	— ³	4.38	1.19	5.25

“Special” Thread Style 3

Special thread, extension, rod eye, blank, welded rod end accessory, etc. are also available.

To order, specify “Style 3” and give desired dimensions for KK, A, W or WF. If otherwise special, furnish dimensioned sketch.

¹ Style 9 stroke restrictions may apply. See Minimum Stroke for Style 9 Rod End in table on How To Order page for details.

² For any special Style 55 dimensions, specify “Style 3” and provide the desired dimensions for AD, AE, AF, AM and WG. For other changes, specify “S” in the model code, and describe the rod end with a dimensioned sketch.

³ These piston rods have four 0.515" dia. x 0.5" deep spanner wrench holes instead of wrench flats on diameter NA.

Mounting Information – 1.50" to 8.00" Bore Series RDH

Basic, No Mount Style T

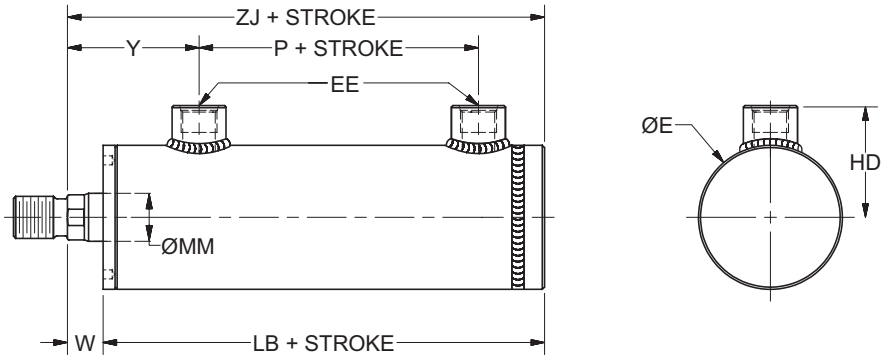
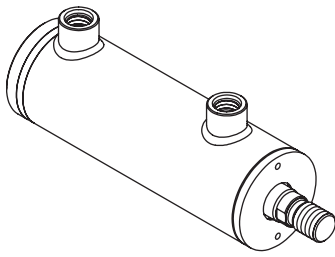

Table 1 – Dimensional and Mounting Data

Bore Ø	Rod No.	E Ø	EE		HD	Add Stroke	
			NPTF ¹	SAE ²		LB	P
1.50	1 (std)	1.88	3/8	6	1.60	3.56	1.19
	2	1.88	3/8	6	1.60	3.94	1.19
2.00	–	2.38	1/2	8	2.04	4.81	1.93
2.50	–	3.00	1/2	8	2.37	5.25	1.88
3.25	–	3.88	3/4	12	2.81	6.00	2.06
4.00	–	4.61	3/4	12	3.20	6.50	2.50
5.00	–	5.75	3/4	12	3.79	7.12	2.56
6.00	–	7.00	1	16	4.58	8.37	3.00
7.00	–	8.00	1 1/4	20	5.11	9.00	3.25
8.00	–	9.25	1 1/4	20	5.76	9.50	3.25

¹ NPTF ports are available for no additional charge

² SAE straight thread o-ring ports are standard

Table 2 – Dimensional and Mounting Data

Bore Ø	Rod No.	MM Rod Ø	W	Y	Add Stroke
					ZJ
1.50	1 (std)	0.625	0.56	2.12	4.12
	2	1.000	0.69	2.62	4.63
2.00	1 (std)	1.000	0.69	2.51	5.50
	2	1.375	0.81	2.63	5.62
2.50	1 (std)	1.000	0.69	2.69	5.94
	2	1.750	0.94	2.94	6.19
	3	1.375	0.81	2.81	6.06
3.25	1 (std)	1.375	0.81	3.07	6.81
	2	2.000	1.00	3.25	7.00
	3	1.750	0.94	3.19	6.94
4.00	1 (std)	1.750	0.94	3.39	7.44
	2	2.500	1.06	3.52	7.56
	3	2.000	1.00	3.46	7.50
5.00	1 (std)	2.000	1.00	3.70	8.12
	2	3.500	1.06	3.76	8.18
	3	2.500	1.06	3.76	8.18
6.00	1 (std)	2.500	1.06	4.24	9.43
	2	4.000	1.06	4.24	9.43
	3	3.000	1.06	4.24	9.43
7.00	1 (std)	3.000	1.06	4.25	10.06
	2	5.000	1.19	4.38	10.19
	3	4.000	1.06	4.25	10.06
8.00	1 (std)	3.500	1.06	4.44	10.56
	2	5.500	1.19	4.56	10.68
	3	4.500	1.19	4.56	10.68



Mounting Information – 1.50" to 8.00" Bore Series RDH

Cap Fixed Eye Mounting Style B

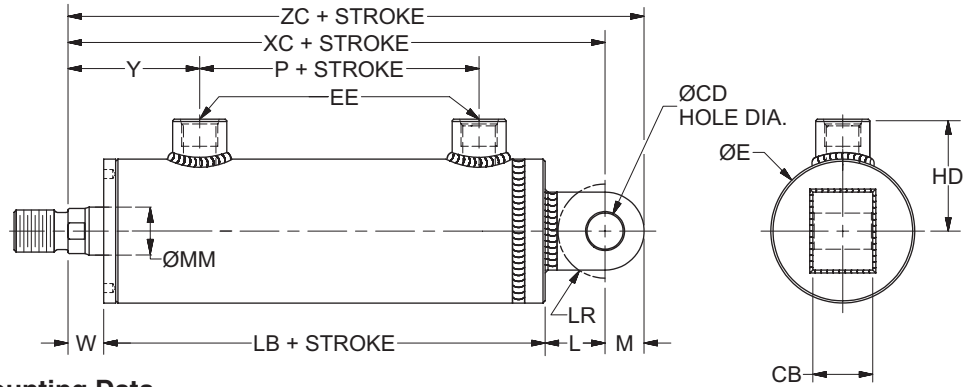
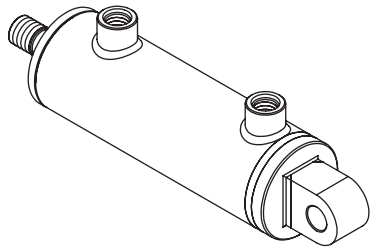

Table 1 – Dimensional and Mounting Data

Bore Ø	Rod No.	CB	CD Ø +.002 -.000	E Ø	EE		HD	L	LR min.	M	Add Stroke	
					NPTF ¹	SAE ²					LB	P
1.50	1 (std)	0.75	.502	1.88	3/8	6	1.60	0.75	0.56	0.50	3.56	1.19
	2	0.75	.502	1.88	3/8	6	1.60	0.75	0.56	0.50	3.94	1.19
2.00	–	1.25	.752	2.38	1/2	8	2.04	1.25	1.06	0.75	4.81	1.93
2.50	–	1.25	.752	3.00	1/2	8	2.37	1.25	0.88	0.75	5.25	1.88
3.25	–	1.50	1.002	3.88	3/4	12	2.81	1.50	1.13	1.00	6.00	2.06
4.00	–	2.00	1.377	4.61	3/4	12	3.20	2.13	1.50	1.38	6.50	2.50
5.00	–	2.50	1.752	5.75	3/4	12	3.79	2.25	1.88	1.75	7.12	2.56
6.00	–	2.50	2.002	7.00	1	16	4.58	2.50	2.13	2.00	8.37	3.00
7.00	–	3.00	2.502	8.00	1 1/4	20	5.11	3.00	2.63	2.50	9.00	3.25
8.00	–	3.00	3.002	9.25	1 1/4	20	5.76	3.25	3.00	2.75	9.50	3.25

¹ NPTF ports are available for no additional charge

² SAE straight thread o-ring ports are standard

Table 2 – Dimensional and Mounting Data

Bore Ø	Rod No.	MM Rod Ø	W	Y	Add Stroke	
					XC	ZC
1.50	1 (std)	0.625	0.56	2.12	4.87	5.37
	2	1.000	0.69	2.62	5.38	5.88
2.00	1 (std)	1.000	0.69	2.51	6.75	7.50
	2	1.375	0.81	2.63	6.87	7.62
2.50	1 (std)	1.000	0.69	2.69	7.19	7.94
	2	1.750	0.94	2.94	7.44	8.19
	3	1.375	0.81	2.81	7.31	8.06
3.25	1 (std)	1.375	0.81	3.07	8.31	9.31
	2	2.000	1.00	3.25	8.50	9.50
	3	1.750	0.94	3.19	8.44	9.44
4.00	1 (std)	1.750	0.94	3.39	9.56	10.94
	2	2.500	1.06	3.52	9.69	11.06
	3	2.000	1.00	3.46	9.62	11.00
5.00	1 (std)	2.000	1.00	3.70	10.37	12.12
	2	3.500	1.06	3.76	10.43	12.18
	3	2.500	1.06	3.76	10.43	12.18
6.00	1 (std)	2.500	1.06	4.24	11.93	13.93
	2	4.000	1.06	4.24	11.93	13.93
	3	3.000	1.06	4.24	11.93	13.93
7.00	1 (std)	3.000	1.06	4.25	13.06	15.56
	2	5.000	1.19	4.38	13.19	15.69
	3	4.000	1.06	4.25	13.06	15.56
8.00	1 (std)	3.500	1.06	4.44	13.81	16.56
	2	5.500	1.19	4.56	13.93	16.68
	3	4.500	1.19	4.56	13.93	16.68

Mounting Information – 1.50" to 8.00" Bore Series RDH

Cap Fixed Clevis Mounting Style BB

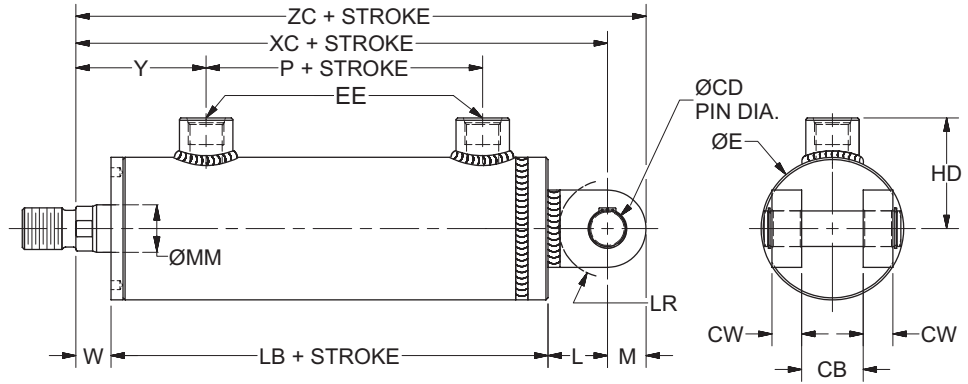
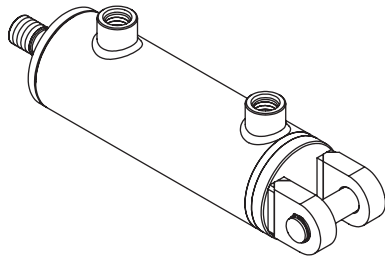

Table 1 – Dimensional and Mounting Data

Bore Ø	Rod No.	CB min.	CD ¹ Ø +.000 - .002	CW	E Ø	EE		HD	L	LR min.	M	Add Stroke	
						NPTF ²	SAE ³					LB	P
1.50	1 (std)	.765	.501	0.50	1.88	3/8	6	1.60	0.75	0.56	0.50	3.56	1.19
	2	.765	.501	0.50	1.88	3/8	6	1.60	0.75	0.56	0.50	3.94	1.19
2.00	–	1.077	.751	0.50	2.38	1/2	8	2.04	1.25	0.88	0.75	4.81	1.93
2.50	–	1.265	.751	0.63	3.00	1/2	8	2.37	1.25	0.88	0.75	5.25	1.88
3.25	–	1.515	1.001	0.75	3.88	3/4	12	2.81	1.50	1.13	1.00	6.00	2.06
4.00	–	2.015	1.376	1.00	4.61	3/4	12	3.20	2.13	1.81	1.38	6.50	2.50
5.00	–	2.515	1.751	1.25	5.75	3/4	12	3.79	2.25	1.88	1.75	7.12	2.56
6.00	–	2.515	2.001	1.25	7.00	1	16	4.58	2.50	2.13	2.00	8.37	3.00
7.00	–	3.015	2.501	1.50	8.00	1 1/4	20	5.11	3.00	2.63	2.50	9.00	3.25
8.00	–	3.015	3.001	1.50	9.25	1 1/4	20	5.76	3.25	3.00	2.75	9.50	3.25

¹ Diameter CD is the Pivot Pin diameter (included)

² NPTF ports are available for no additional charge

³ SAE straight thread o-ring ports are standard

Table 2 – Dimensional and Mounting Data

Bore Ø	Rod No.	MM Rod Ø	W	Y	Add Stroke	
					XC	ZC
1.50	1 (std)	0.625	0.56	2.12	4.87	5.37
	2	1.000	0.69	2.62	5.38	5.88
2.00	1 (std)	1.000	0.69	2.51	6.75	7.50
	2	1.375	0.81	2.63	6.87	7.62
2.50	1 (std)	1.000	0.69	2.69	7.19	7.94
	2	1.750	0.94	2.94	7.44	8.19
	3	1.375	0.81	2.81	7.31	8.06
3.25	1 (std)	1.375	0.81	3.07	8.31	9.31
	2	2.000	1.00	3.25	8.50	9.50
	3	1.750	0.94	3.19	8.44	9.44
4.00	1 (std)	1.750	0.94	3.39	9.56	10.94
	2	2.500	1.06	3.52	9.69	11.06
	3	2.000	1.00	3.46	9.62	11.00
5.00	1 (std)	2.000	1.00	3.70	10.37	12.12
	2	3.500	1.06	3.76	10.43	12.18
	3	2.500	1.06	3.76	10.43	12.18
6.00	1 (std)	2.500	1.06	4.24	11.93	13.93
	2	4.000	1.06	4.24	11.93	13.93
	3	3.000	1.06	4.24	11.93	13.93
7.00	1 (std)	3.000	1.06	4.25	13.06	15.56
	2	5.000	1.19	4.38	13.19	15.69
	3	4.000	1.06	4.25	13.06	15.56
8.00	1 (std)	3.500	1.06	4.44	13.81	16.56
	2	5.500	1.19	4.56	13.93	16.68
	3	4.500	1.19	4.56	13.93	16.68



Mounting Information – 1.50" to 6.00" Bore

Spherical Bearing Cap End Mounting
Inch Size Bearing
Style SB

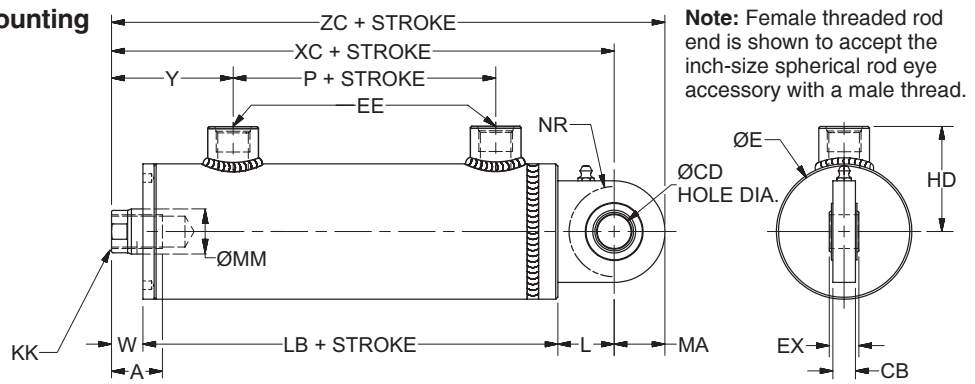
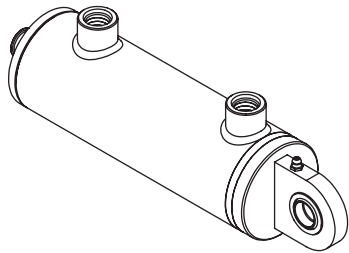

Note: Standard spherical bearing is maintenance-free (sealed) for hole diameters larger than 0.5000".

Table 1 — Dimensional and Mounting Data

Bore Ø	Rod No.	MM Rod Ø	Thread		A	CB	CD ² Ø +.0000 - .0005	EX	L	MA	NR min.	W	Y	Add Stroke			
			Style 9A KK ¹	Style 7A KK ¹										XC	ZC		
1.50	1 (std)	0.625	7/16-20	—	0.75	0.38	0.5000	0.44	0.75	0.75	0.56	0.56	2.12	4.88	6.00		
	2	1.000	—	7/16-20	0.75									0.69	2.62	5.38	6.13
2.00	1 (std)	1.000	3/4-16	—	1.13	0.56	0.7500	0.66	1.25	1.00	1.06	0.69	2.51	6.75	7.75		
	2	1.375	—	3/4-16	1.13									0.81	2.63	6.87	7.87
2.50	1 (std)	1.000	3/4-16	—	1.13	0.56	0.7500	0.66	1.25	1.00	1.06	0.69	2.69	7.19	8.19		
	2	1.750	—	3/4-16	1.13									0.94	2.94	7.44	8.44
	3	1.375	—	3/4-16	1.13									0.81	2.81	7.31	8.31
3.25	1 (std)	1.375	1-14	—	1.63	0.75	1.0000	0.88	1.50	1.25	1.31	0.81	3.07	8.31	9.56		
	2	2.000	—	1-14	1.63									1.00	3.25	8.50	9.75
	3	1.750	—	1-14	1.63									0.94	3.19	8.44	9.69
4.00	1 (std)	1.750	1 1/4-12	—	2.00	1.00	1.3750	1.19	2.13	1.88	1.88	0.94	3.39	9.56	11.44		
	2	2.500	—	1 1/4-12	2.00									1.06	3.52	9.69	11.56
	3	2.000	—	1 1/4-12	2.00									1.00	3.46	9.62	11.50
5.00	1 (std)	2.000	1 1/2-12	—	2.25	1.25	1.7500	1.53	2.25	2.50	1.94	1.00	3.70	10.37	12.87		
	2	3.500	—	1 1/2-12	2.25									1.06	3.76	10.43	12.93
	3	2.500	—	1 1/2-12	2.25									1.06	3.76	10.43	12.93
6.00	1 (std)	2.500	1 7/8-12	—	3.00	1.50	2.0000	1.75	2.50	2.50	2.19	1.06	4.24	11.93	14.43		
	2	4.000	—	1 7/8-12	3.00									1.06	4.24	11.93	14.43
	3	3.000	—	1 7/8-12	3.00									1.06	4.24	11.93	14.43
7.00	See SBM Mount on the next page																
8.00																	

Note: for additional dimensions see Style BB mount.

² Dimension CD is the hole diameter.

¹ These thread dimensions match mating thread dimensions of an inch-size spherical rod eye with the same hole diameter as the cap end. It must be purchased separately; see page 26 for detailed information.

Table 2 – Recommended maximum swivel angle on each side of the cylinder centerline.

Bore Ø	Head End Mounted		Cap End Mounted	
	Angle a	Tan. of a	Angle a	Tan. of a
1.50	2.00°	.035	2.00°	.035
2.00	2.50°	.044	4.50°	.079
2.50	2.50°	.044	4.50°	.079
3.25	3.00°	.052	3.00°	.052
4.00	2.50°	.044	3.00°	.052
5.00	3.00°	.052	3.00°	.052
6.00	3.00°	.052	3.00°	.052

Note: Dimension X is the maximum off-center mounting of the cylinder. To determine dimension X for various stroke lengths, multiply the distance between pivot pin holes by tangent of angle a. For extended position use XL + 2 x STROKE.

Mounting Information³

Head End Mounting

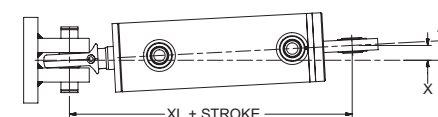

Cap End Mounting

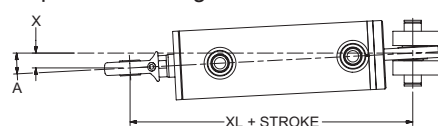

³ Please see spherical mounting accessories on page 26.

SB Pressure Ratings

Bore Ø	Maximum Operating Pressure (psi) ⁴
1.50	1,500
2.00	2,200
2.50	1,450
3.25	1,500
4.00	1,850
5.00	2,000
6.00	1,800

⁴ Pressure ratings are based on standard commercial bearing ratings. For spherical bearing mount rated to 3,000 psi, please see the SBM Mount on the next page.

Mounting Information - 1.50" to 8.00" Bore

Spherical Bearing Cap End Mounting
Metric Size Bearing
Style SBM

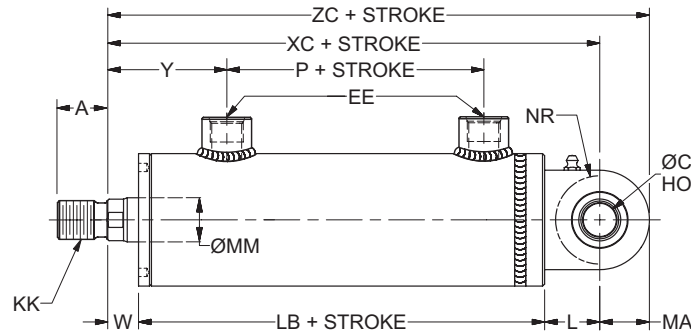
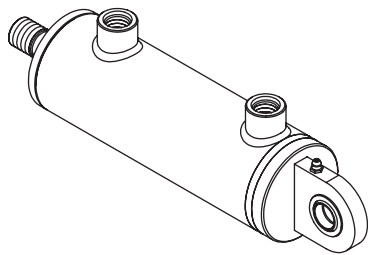

Note: Male threaded rod end is shown to accept the metric spherical rod eye accessory with a female thread.

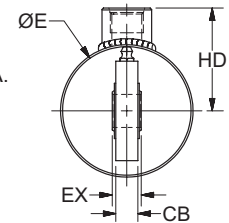

Note: Standard spherical bearing is maintenance-free (sealed).

Although the standard SB Mount has derated pressure ratings below 3,000 psi, the SBM Mount is a standard spherical bearing mount rated at 3,000 psi¹. Please note that the SBM Mount has slightly different lug dimensions

and a metric bearing size. Metric spherical rod eyes are available on page 26. Information on additional metric accessories is available from the MHP Series ISO Hydraulic Tie Rod Cylinder catalog, or consult factory.

Table 1 — Dimensional and Mounting Data

Bore Ø	Rod No.	MM Rod Ø	A ² Thread Length (mm)	KK ² Thread Style 7M Male	W	Y	Add Stroke		Dimensions at cap end (mm)					
							XC	ZC	CB (mm)	CD ³ Ø (mm)	EX (mm)	L (mm)	MA (mm)	NR min. (mm)
1.50	1 (std)	0.625	0.71 (18)	M14X1.5	0.56	2.12	5.11	6.25	0.51 (13)	0.7874 -0.0005 (20 -0.012)	0.63 (16)	0.98 (25)	1.14 (29)	0.87 (22)
	2	1.000	0.71 (18)	M14X1.5	0.69	2.62	5.61	6.75	0.51 (13)	0.7874 -0.0005 (20 -0.012)	0.63 (16)	0.98 (25)	1.14 (29)	0.87 (22)
2.00	1 (std)	1.000	0.87 (22)	M16X1.5	0.69	2.51	6.72	8.02	0.67 (17)	0.9843 -0.0005 (25 -0.012)	0.79 (20)	1.22 (31)	1.30 (33)	1.10 (28)
	2	1.375	0.87 (22)	M16X1.5	0.81	2.63	6.84	8.14	0.67 (17)	0.9843 -0.0005 (25 -0.012)	0.79 (20)	1.22 (31)	1.30 (33)	1.10 (28)
2.50	1 (std)	1.000	1.10 (28)	M20X1.5	0.69	2.69	7.43	9.01	0.75 (19)	1.1811 -0.0005 (30 -0.012)	0.87 (22)	1.50 (38)	1.57 (40)	1.38 (35)
	2	1.750	1.10 (28)	M20X1.5	0.94	2.94	7.68	9.26	0.75 (19)	1.1811 -0.0005 (30 -0.012)	0.87 (22)	1.50 (38)	1.57 (40)	1.38 (35)
	3	1.375	1.10 (28)	M20X1.5	0.81	2.81	7.56	9.13	0.75 (19)	1.1811 -0.0005 (30 -0.012)	0.87 (22)	1.50 (38)	1.57 (40)	1.38 (35)
3.25	1 (std)	1.375	1.42 (36)	M27X2	0.81	3.07	8.70	10.67	0.91 (23)	1.5748 -0.0005 (40 -0.012)	1.10 (28)	1.89 (48)	1.97 (50)	1.73 (44)
	2	2.000	1.42 (36)	M27X2	1.00	3.25	8.89	10.86	0.91 (23)	1.5748 -0.0005 (40 -0.012)	1.10 (28)	1.89 (48)	1.97 (50)	1.73 (44)
	3	1.750	1.42 (36)	M27X2	0.94	3.19	8.83	10.80	0.91 (23)	1.5748 -0.0005 (40 -0.012)	1.10 (28)	1.89 (48)	1.97 (50)	1.73 (44)
4.00	1 (std)	1.750	1.77 (45)	M33X2	0.94	3.39	9.72	12.16	1.18 (30)	1.9685 -0.0005 (50 -0.012)	1.38 (35)	2.28 (58)	2.44 (62)	2.13 (54)
	2	2.500	1.77 (45)	M33X2	1.06	3.52	9.84	12.28	1.18 (30)	1.9685 -0.0005 (50 -0.012)	1.38 (35)	2.28 (58)	2.44 (62)	2.13 (54)
	3	2.000	1.77 (45)	M33X2	1.00	3.46	9.78	12.22	1.18 (30)	1.9685 -0.0005 (50 -0.012)	1.38 (35)	2.28 (58)	2.44 (62)	2.13 (54)
5.00	1 (std)	2.000	2.20 (56)	M42X2	1.00	3.70	10.95	14.10	1.50 (38)	2.3622 -0.0006 (60 -0.015)	1.73 (44)	2.83 (72)	3.15 (80)	2.68 (68)
	2	3.500	2.20 (56)	M42X2	1.06	3.76	11.01	14.16	1.50 (38)	2.3622 -0.0006 (60 -0.015)	1.73 (44)	2.83 (72)	3.15 (80)	2.68 (68)
	3	2.500	2.20 (56)	M42X2	1.06	3.76	11.01	14.16	1.50 (38)	2.3622 -0.0006 (60 -0.015)	1.73 (44)	2.83 (72)	3.15 (80)	2.68 (68)
6.00	1 (std)	2.500	2.48 (63)	M48X2	1.06	4.24	13.05	16.99	1.85 (47)	3.1496 -0.0006 (80 -0.015)	2.17 (55)	3.62 (92)	3.94 (100)	3.46 (88)
	2	4.000	2.48 (63)	M48X2	1.06	4.24	13.05	16.99	1.85 (47)	3.1496 -0.0006 (80 -0.015)	2.17 (55)	3.62 (92)	3.94 (100)	3.46 (88)
	3	3.000	2.48 (63)	M48X2	1.06	4.24	13.05	16.99	1.85 (47)	3.1496 -0.0006 (80 -0.015)	2.17 (55)	3.62 (92)	3.94 (100)	3.46 (88)
7.00 ¹	1 (std)	3.000	2.48 (63)	M48X2	1.06	4.25	13.68	17.62	1.85 (47)	3.1496 -0.0006 (80 -0.015)	2.17 (55)	3.62 (92)	3.94 (100)	3.46 (88)
	2	5.000	2.48 (63)	M48X2	1.19	4.38	13.81	17.75	1.85 (47)	3.1496 -0.0006 (80 -0.015)	2.17 (55)	3.62 (92)	3.94 (100)	3.46 (88)
	3	4.000	2.48 (63)	M48X2	1.06	4.25	13.68	17.62	1.85 (47)	3.1496 -0.0006 (80 -0.015)	2.17 (55)	3.62 (92)	3.94 (100)	3.46 (88)
8.00	1 (std)	3.500	3.35 (85)	M64X3	1.06	4.44	15.12	19.85	2.24 (57)	3.9370 -0.0008 (100 -0.020)	2.76 (70)	4.57 (116)	4.72 (120)	4.37 (111)
	2	5.500	3.35 (85)	M64X3	1.19	4.56	15.25	19.97	2.24 (57)	3.9370 -0.0008 (100 -0.020)	2.76 (70)	4.57 (116)	4.72 (120)	4.37 (111)
	3	4.500	3.35 (85)	M64X3	1.19	4.56	15.25	19.97	2.24 (57)	3.9370 -0.0008 (100 -0.020)	2.76 (70)	4.57 (116)	4.72 (120)	4.37 (111)

Note: for additional dimensions, please see Style SB Mount. For recommended maximum swivel angles, please see Table 2 and sketch on the previous page.

¹ Pressure ratings based on standard commercial bearing ratings. The 7.00" bore SBM Mount has a maximum pressure rating of 2,450 psi.

² These thread dimensions match mating thread dimensions of a metric spherical rod eye with the same hole diameter as the cap end. It must be purchased separately; see page 26 for detailed information.

³ Dimension CD is the hole diameter.

Mounting Information – 1.50" to 8.00" Bore

Series RDH

Crosstube Cap End Mounting
Style TT

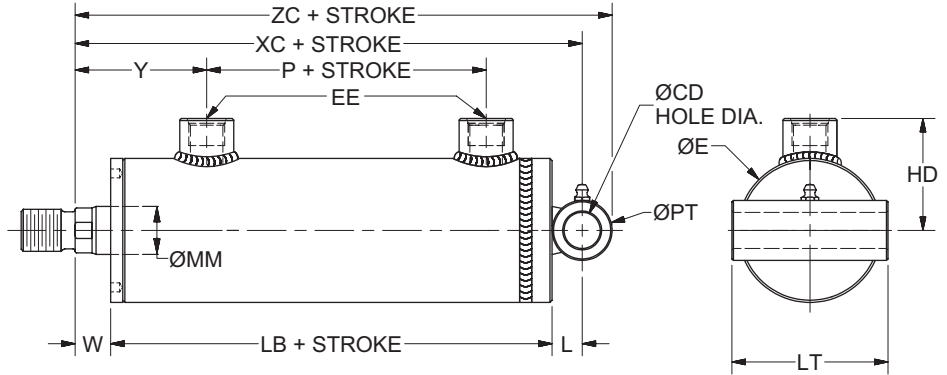
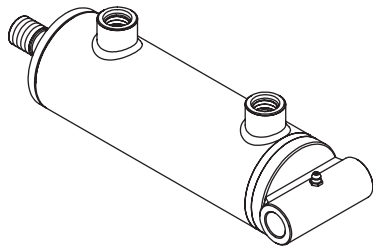

Table 1 – Dimensional and Mounting Data

Bore Ø	Rod No.	CD Ø +.002 - .000	E Ø	EE		HD	L	LT	PT Ø	Add Stroke	
				NPTF ¹	SAE ²					LB	P
1.50	1 (std)	0.752	1.88	3/8	6	1.60	0.63	2.38	1.25	3.56	1.19
	2	0.752	1.88	3/8	6	1.60	0.63	2.38	1.25	3.94	1.19
2.00	–	0.752	2.38	1/2	8	2.04	0.63	2.88	1.25	4.81	1.93
2.50	–	1.002	3.00	1/2	8	2.37	0.75	3.50	1.50	5.25	1.88
3.25	–	1.252	3.88	3/4	12	2.81	0.94	4.38	1.88	6.00	2.06
4.00	–	1.377	4.61	3/4	12	3.20	1.00	5.13	2.00	6.50	2.50
5.00	–	1.752	5.75	3/4	12	3.79	1.38	6.25	2.75	7.12	2.56
6.00	–	2.002	7.00	1	16	4.58	1.50	7.50	3.00	8.37	3.00
7.00	–	2.502	8.00	1 1/4	20	5.11	1.88	8.50	3.75	9.00	3.25
8.00	–	3.002	9.25	1 1/4	20	5.76	2.00	9.75	4.00	9.50	3.25

¹ NPTF ports are available for no additional charge

² SAE straight thread o-ring ports are standard

Table 2 – Dimensional and Mounting Data

Bore Ø	Rod No.	MM Rod Ø	W	Y	Add Stroke	
					XC	ZC
1.50	1 (std)	0.625	0.56	2.12	4.75	5.37
	2	1.000	0.69	2.62	5.25	5.88
2.00	1 (std)	1.000	0.69	2.51	6.13	6.75
	2	1.375	0.81	2.63	6.25	6.87
2.50	1 (std)	1.000	0.69	2.69	6.69	7.44
	2	1.750	0.94	2.94	6.94	7.69
	3	1.375	0.81	2.81	6.81	7.56
3.25	1 (std)	1.375	0.81	3.07	7.75	8.69
	2	2.000	1.00	3.25	7.94	8.88
	3	1.750	0.94	3.19	7.88	8.81
4.00	1 (std)	1.750	0.94	3.39	8.44	9.44
	2	2.500	1.06	3.52	8.56	9.56
	3	2.000	1.00	3.46	8.50	9.50
5.00	1 (std)	2.000	1.00	3.70	9.49	10.87
	2	3.500	1.06	3.76	9.55	10.93
	3	2.500	1.06	3.76	9.55	10.93
6.00	1 (std)	2.500	1.06	4.24	10.93	12.43
	2	4.000	1.06	4.24	10.93	12.43
	3	3.000	1.06	4.24	10.93	12.43
7.00	1 (std)	3.000	1.06	4.25	11.94	13.81
	2	5.000	1.19	4.38	12.06	13.94
	3	4.000	1.06	4.25	11.94	13.81
8.00	1 (std)	3.500	1.06	4.44	12.56	14.56
	2	5.500	1.19	4.56	12.68	14.68
	3	4.500	1.19	4.56	12.68	14.68

Intermediate Fixed Trunnion Mounting
Style DD

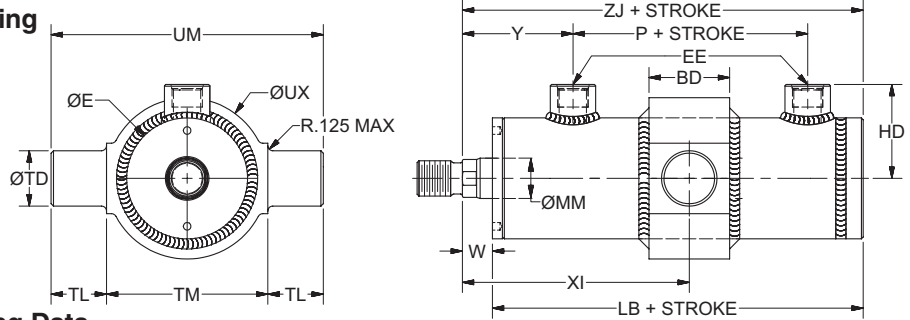
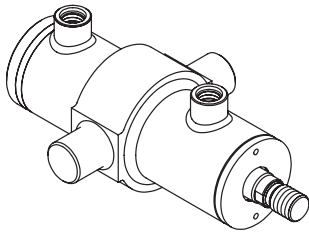

Table 1 – Dimensional and Mounting Data

Bore Ø	Rod No.	BD	E Ø	EE		HD	TD Ø +0.000 -0.001	TL	TM	UM	UX Ø	Add Stroke	
				NPTF ¹	SAE ²							LB	P
1.50	1 (std)	1.38	1.88	3/8	6	1.60	1.000	1.00	3.00	5.00	3.00	3.56	1.19
	2	1.38	1.88	3/8	6	1.60	1.000	1.00	3.00	5.00	3.00	3.94	1.19
2.00	–	1.75	2.38	1/2	8	2.04	1.375	1.38	3.50	6.25	3.50	4.81	1.93
2.50	–	1.75	3.00	1/2	8	2.37	1.375	1.38	4.00	6.75	4.00	5.25	1.88
3.25	–	2.25	3.88	3/4	12	2.81	1.750	1.75	5.00	8.50	5.00	6.00	2.06
4.00	–	2.50	4.61	3/4	12	3.20	2.000	1.75	5.50	9.00	5.50	6.50	2.50
5.00	–	3.00	5.75	3/4	12	3.79	2.500	1.75	7.00	10.50	7.00	7.12	2.56
6.00	–	3.50	7.00	1	16	4.58	3.000	2.00	8.50	12.50	8.50	8.37	3.00
7.00	–	4.00	8.00	1 1/4	20	5.11	3.500 ³	2.50	9.75	14.75	9.75	9.00	3.25
8.00	–	4.50	9.25	1 1/4	20	5.76	4.000 ³	3.00	11.00	17.00	11.00	9.50	3.25

¹ NPTF ports are available for no additional charge

² SAE straight thread o-ring ports are standard

³ Tolerance is +.000/-0.002

Table 2 – Dimensional and Mounting Data

Bore Ø	Rod No.	MM Rod Ø	W	Y	Min. Stroke ⁴	Min. XI ⁵	Add Stroke	
							Max. XI ⁶	ZJ
1.50	1 (std)	0.625	0.56	2.12	7.06	6.25	-0.81	4.13
	2	1.000	0.69	2.62	7.06	6.75	-0.31	4.63
2.00	1 (std)	1.000	0.69	2.51	6.95	6.95	0.00	5.50
	2	1.375	0.81	2.63	6.95	7.07	0.12	5.62
2.50	1 (std)	1.000	0.69	2.69	7.00	7.13	0.13	5.94
	2	1.750	0.94	2.94	7.00	7.38	0.38	6.19
	3	1.375	0.81	2.81	7.00	7.25	0.25	6.06
3.25	1 (std)	1.375	0.81	3.07	7.57	7.88	0.31	6.81
	2	2.000	1.00	3.25	7.57	8.07	0.50	7.00
	3	1.750	0.94	3.19	7.57	8.00	0.44	6.94
4.00	1 (std)	1.750	0.94	3.39	7.38	8.33	0.96	7.44
	2	2.500	1.06	3.52	7.38	8.45	1.08	7.56
	3	2.000	1.00	3.46	7.38	8.39	1.02	7.50
5.00	1 (std)	2.000	1.00	3.70	7.82	8.89	1.07	8.12
	2	3.500	1.06	3.76	7.82	8.95	1.13	8.18
	3	2.500	1.06	3.76	7.82	8.95	1.13	8.18
6.00	1 (std)	2.500	1.06	4.24	8.25	9.87	1.62	9.43
	2	4.000	1.06	4.24	8.25	9.87	1.62	9.43
	3	3.000	1.06	4.24	8.25	9.87	1.62	9.43
7.00	1 (std)	3.000	1.06	4.25	9.00	10.38	1.38	10.06
	2	5.000	1.19	4.38	9.00	10.51	1.51	10.19
	3	4.000	1.06	4.25	9.00	10.38	1.38	10.06
8.00	1 (std)	3.500	1.06	4.44	9.50	10.81	1.31	10.56
	2	5.500	1.19	4.56	9.50	10.94	1.44	10.68
	3	4.500	1.19	4.56	9.50	10.94	1.44	10.68

⁴ Shorter net/working strokes are available with the use of a stop tube; however, the overall length of the cylinder will increase. To achieve your desired net/working stroke that is less than the minimum shown, please specify the stop tube length as the minimum stroke per the table above. Gross stroke (designated in the model code) will be the combination of the stop tube length and desired net (working) stroke length. If shortest total cylinder length is required and a stop tube is unacceptable, please consult factory for a special quote.

⁵ Cylinders with an XI dimension shorter than the standard minimum are available with a special modification; please consult factory.

⁶ Add this number to the stroke to determine the maximum allowable XI dimension with the standard rod extension (W dimension).

Mounting Information – 1.50" to 8.00" Bore

Round Head Flange Mounting¹
Style J

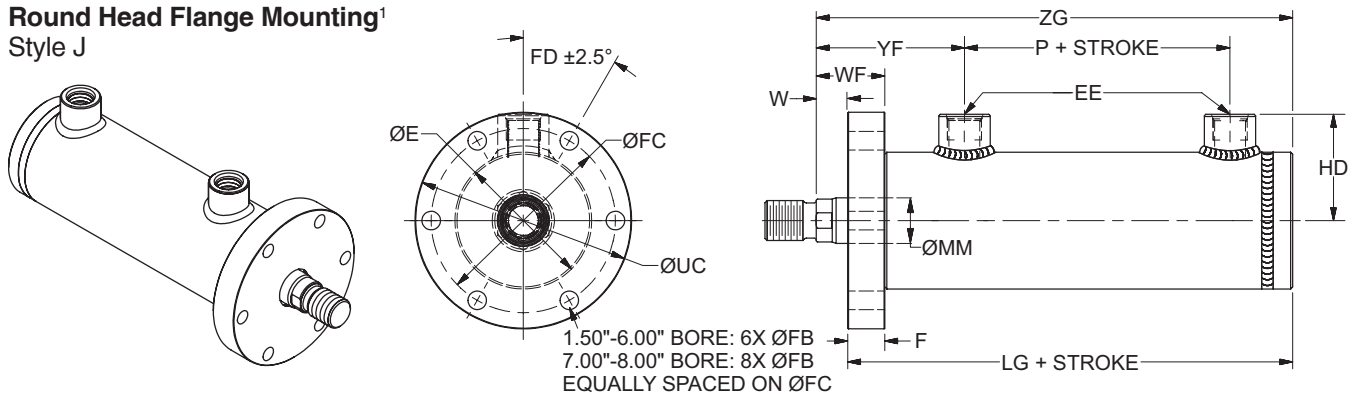

Table 1 – Dimensional and Mounting Data

Bore Ø	E Ø	EE		F	FB Ø	FC Ø	FD	HD	UC Ø	Add Stroke	
		NPTF ²	SAE ³							LG	P
1.50	1.88	3/8	6	0.63	0.28	2.75	30°	1.60	3.25	3.94	1.19
2.00	2.38	1/2	8	0.69	0.28	3.25	30°	2.04	3.75	5.25	1.93
2.50	3.00	1/2	8	0.81	0.41	4.00	30°	2.37	4.75	5.81	1.88
3.25	3.88	3/4	12	1.00	0.53	5.25	30°	2.81	6.13	6.75	2.06
4.00	4.61	3/4	12	1.25	0.66	6.25	30°	3.20	7.63	7.50	2.50
5.00	5.75	3/4	12	1.63	0.79	7.75	30°	3.79	9.00	8.43	2.56
6.00	7.00	1	16	1.88	0.91	9.38	30°	4.58	10.88	9.87	3.00
7.00	8.00	1 1/4	20	2.38	1.04	10.50	22.5°	5.11	12.25	11.00	3.25
8.00	9.25	1 1/4	20	2.50	1.19	12.13	22.5°	5.76	14.00	11.50	3.25

¹ For a Round Head Flange Mounting that includes a male pilot, concentric with the rod, please see the JP Mount on page 35.

² NPTF ports are available for no additional charge

³ SAE straight thread o-ring ports are standard

Table 2 – Dimensional and Mounting Data

Bore Ø	Rod No.	MM Rod Ø	W	WF	YF	Add Stroke
						ZG
1.50	1 (std)	0.625	0.56	1.19	2.50	4.50
	2	1.000	0.69	1.32	2.62	4.63
2.00	1 (std)	1.000	0.69	1.38	2.95	5.94
	2	1.375	0.81	1.50	3.07	6.06
2.50	1 (std)	1.000	0.69	1.50	3.25	6.50
	2	1.750	0.94	1.75	3.50	6.75
	3	1.375	0.81	1.62	3.37	6.62
3.25	1 (std)	1.375	0.81	1.81	3.82	7.56
	2	2.000	1.00	2.00	4.00	7.75
	3	1.750	0.94	1.94	3.94	7.69
4.00	1 (std)	1.750	0.94	2.19	4.39	8.44
	2	2.500	1.06	2.31	4.52	8.56
	3	2.000	1.00	2.25	4.46	8.50
5.00	1 (std)	2.000	1.00	2.63	5.01	9.43
	2	3.500	1.06	2.69	5.08	9.49
	3	2.500	1.06	2.69	5.08	9.49
6.00	1 (std)	2.500	1.06	2.94	5.74	10.93
	2	4.000	1.06	2.94	5.74	10.93
	3	3.000	1.06	2.94	5.74	10.93
7.00	1 (std)	3.000	1.06	3.44	6.25	12.06
	2	5.000	1.19	3.44	6.38	12.19
	3	4.000	1.06	3.44	6.25	12.06
8.00	1 (std)	3.500	1.06	3.56	6.44	12.56
	2	5.500	1.19	3.69	6.56	12.68
	3	4.500	1.19	3.69	6.56	12.68

Note: For 1.50" to 6.00" bores, the port position at the head end must be position 1 (standard, as shown) or position 3. Port position at the cap end may be 1, 2, 3 or 4. Please see Figure 1 on page 49 for additional information on port positions.

Mounting Information – 1.50" to 8.00" Bore Series RDH

Round Cap Flange Mounting Style H

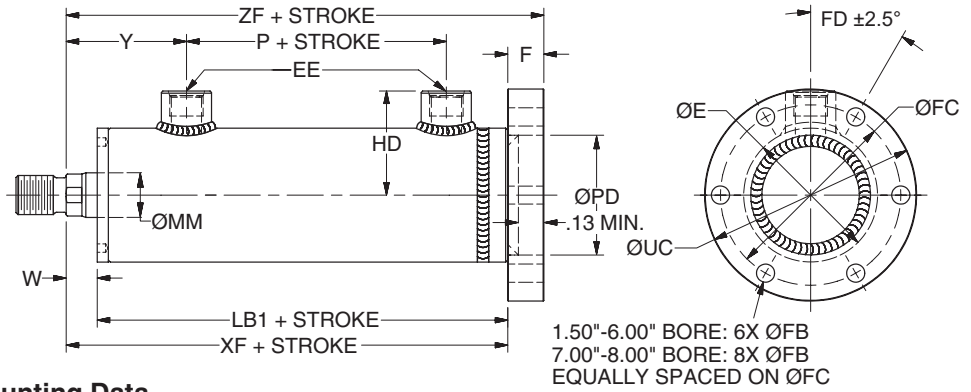
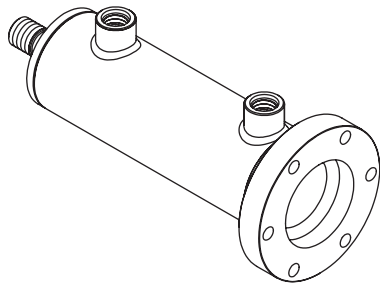

Table 1 – Dimensional and Mounting Data

Bore Ø	Rod No.	E Ø	EE		F	FB Ø	FC Ø	FD	HD	PD ³ Ø	UC Ø	Add Stroke	
			NPTF ¹	SAE ²								LB1	P
1.50	1 (std)	1.88	3/8	6	0.63	0.28	2.75	30°	1.60	1.50	3.25	3.44	1.19
	2	1.88	3/8	6	0.63	0.28	2.75	30°	1.60	1.50	3.25	3.81	1.19
2.00	–	2.38	1/2	8	0.69	0.28	3.25	30°	2.04	2.00	3.75	4.69	1.93
2.50	–	3.00	1/2	8	0.81	0.41	4.00	30°	2.37	2.50	4.75	5.13	1.88
3.25	–	3.88	3/4	12	1.00	0.53	5.25	30°	2.81	3.25	6.13	5.88	2.06
4.00	–	4.61	3/4	12	1.25	0.66	6.25	30°	3.20	4.00	7.63	6.36	2.50
5.00	–	5.75	3/4	12	1.63	0.79	7.75	30°	3.79	5.00	9.00	6.99	2.56
6.00	–	7.00	1	16	1.88	0.91	9.38	30°	4.58	6.00	10.88	8.25	3.00
7.00	–	8.00	1 1/4	20	2.38	1.04	10.50	22.5°	5.11	7.00	12.25	8.88	3.25
8.00	–	9.25	1 1/4	20	2.50	1.19	12.13	22.5°	5.76	8.00	14.00	9.37	3.25

¹ NPTF ports are available for no additional charge

² SAE straight thread o-ring ports are standard

³ ØPD may be used to help center the cylinder during installation. However, typical cylinder assembly tolerances may require repositioning of the cylinder in order to align its travel with the load movement.

Table 2 – Dimensional and Mounting Data

Bore Ø	Rod No.	MM Rod Ø	W	Y	Add Stroke	
					XF	ZF
1.50	1 (std)	0.625	0.56	2.12	4.00	4.62
	2	1.000	0.69	2.62	4.50	5.13
2.00	1 (std)	1.000	0.69	2.51	5.38	6.06
	2	1.375	0.81	2.63	5.50	6.18
2.50	1 (std)	1.000	0.69	2.69	5.81	6.63
	2	1.750	0.94	2.94	6.06	6.88
	3	1.375	0.81	2.81	5.94	6.75
3.25	1 (std)	1.375	0.81	3.07	6.69	7.69
	2	2.000	1.00	3.25	6.88	7.88
	3	1.750	0.94	3.19	6.81	7.81
4.00	1 (std)	1.750	0.94	3.39	7.31	8.56
	2	2.500	1.06	3.52	7.44	8.69
	3	2.000	1.00	3.46	7.37	8.62
5.00	1 (std)	2.000	1.00	3.70	7.99	9.62
	2	3.500	1.06	3.76	8.05	9.68
	3	2.500	1.06	3.76	8.05	9.68
6.00	1 (std)	2.500	1.06	4.24	9.31	11.18
	2	4.000	1.06	4.24	9.31	11.18
	3	3.000	1.06	4.24	9.31	11.18
7.00	1 (std)	3.000	1.06	4.25	9.94	12.31
	2	5.000	1.19	4.38	10.06	12.44
	3	4.000	1.06	4.25	9.94	12.31
8.00	1 (std)	3.500	1.06	4.44	10.43	12.94
	2	5.500	1.19	4.56	10.56	13.06
	3	4.500	1.19	4.56	10.56	13.06

Note: For 1.50" to 6.00" bores, the port position at the cap end must be position 1 (standard, as shown) or position 3. Port position at the head end may be 1, 2, 3 or 4. Please see Figure 1 on page 49 for additional information on port positions.



**Double Rod Cylinder
Style KT**

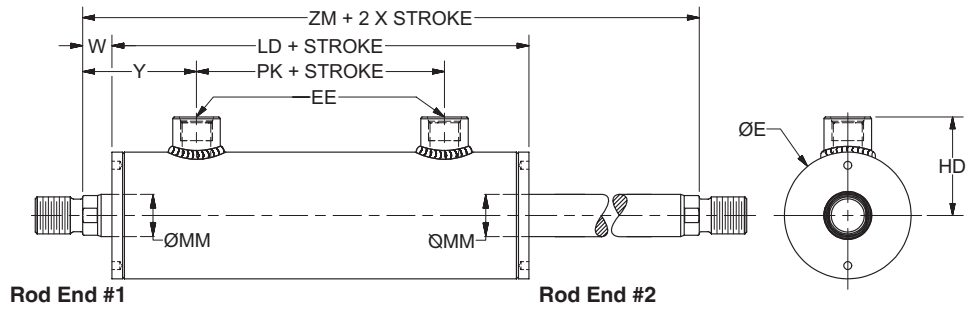
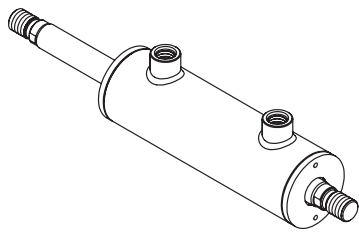

Table 1 – Dimensional and Mounting Data

Bore Ø	Rod No.	MM Rod Ø	EE		W	Y	YF J Mount	Min. Stroke ¹ T, J Mount	Min. Stroke ¹ DD Mount	Add Stroke			Add 2X Stroke	
			NPTF	SAE						LD	LGK	PK	ZM	ZM (J)
1.50	1 (std)	0.625	3/8	6	0.56	2.12	2.50	2.57	7.06	4.34	4.71	1.22	5.48	5.85
	2	1.000	3/8	6	0.69	2.62	2.62	2.57	7.06	5.09	5.09	1.22	6.48	6.48
2.00	1 (std)	1.000	1/2	8	0.69	2.51	2.95	1.25	6.94	5.40	5.83	1.76	6.79	7.23
	2	1.375	1/2	8	0.81	2.63	3.07	1.27	6.94	5.40	5.83	1.76	7.04	7.48
2.50	1 (std)	1.000	1/2	8	0.69	2.69	3.25	1.13	7.00	5.90	6.46	1.90	7.29	7.85
	2	1.750	1/2	8	0.94	2.94	3.50	1.13	7.00	5.90	6.46	1.90	7.79	8.35
	3	1.375	1/2	8	0.81	2.81	3.37	1.13	7.00	5.90	6.46	1.90	7.54	8.10
3.25	1 (std)	1.375	3/4	12	0.81	3.07	3.82	1.00	7.56	6.52	7.27	2.02	8.16	8.91
	2	2.000	3/4	12	1.00	3.25	4.00	1.00	7.56	6.52	7.27	2.02	8.54	9.29
	3	1.750	3/4	12	0.94	3.19	3.94	1.00	7.56	6.52	7.27	2.02	8.42	9.17
4.00	1 (std)	1.750	3/4	12	0.94	3.39	4.39	0.63	7.38	7.27	8.27	2.35	9.17	10.17
	2	2.500	3/4	12	1.06	3.52	4.52	0.75	7.38	7.27	8.27	2.35	9.41	10.41
	3	2.000	3/4	12	1.00	3.46	4.46	0.75	7.38	7.27	8.27	2.35	9.29	10.29
5.00	1 (std)	2.000	3/4	12	1.00	3.70	5.01	0.51	7.81	7.90	9.21	2.50	9.93	11.24
	2	3.500	3/4	12	1.06	3.76	5.08	0.50	7.81	7.90	9.21	2.50	10.05	11.36
	3	2.500	3/4	12	1.06	3.76	5.08	0.50	7.81	7.90	9.21	2.50	10.05	11.36
6.00	1 (std)	2.500	1	16	1.06	4.24	5.74	0.25	8.25	9.15	10.65	2.79	11.31	12.81
	2	4.000	1	16	1.06	4.24	5.74	0.25	8.25	9.15	10.65	2.79	11.31	12.81
	3	3.000	1	16	1.06	4.24	5.74	0.25	8.25	9.15	10.65	2.79	11.31	12.81
7.00	1 (std)	3.000	1 1/4	20	1.06	4.25	6.25	0.00	9.00	9.54	11.54	3.16	11.68	13.68
	2	5.000	1 1/4	20	1.19	4.38	6.38	0.00	9.00	9.54	11.54	3.16	11.93	13.93
	3	4.000	1 1/4	20	1.06	4.25	6.25	0.00	9.00	9.54	11.54	3.16	11.68	13.68
8.00	1 (std)	3.500	1 1/4	20	1.06	4.44	6.44	0.00	9.50	9.96	11.96	3.21	12.10	14.10
	2	5.500	1 1/4	20	1.19	4.56	6.56	0.00	9.50	9.96	11.96	3.21	12.35	14.35
	3	4.500	1 1/4	20	1.19	4.56	6.56	0.00	9.50	9.96	11.96	3.21	12.35	14.35
Replaces dimension:										LB	LG	P	-	-
On single rod mounting styles:										T ² , J ³ , DD ⁴				

¹ Ports in the same position (inline) will require some minimum stroke amount per bore and rod number combination. Most of this minimum stroke can be reduced or eliminated if one port is relocated to a different position (except for the DD Mount). For inline ports, shorter net/working strokes are available with the use of a stop tube; however, the overall length of the cylinder will increase. To achieve your desired net/working stroke that is less than the minimum shown, please specify the stop tube length as the minimum stroke

per the table above. Gross stroke (designated in the model code) will be the combination of the stop tube length and desired net (working) stroke length. If shortest total cylinder length is required and a stop tube is unacceptable, please consult factory.

² Supplemental dimensions on page 11.

³ Supplemental dimensions on page 18.

⁴ Specify XI dimension from rod end #1. Supplemental dimensions on page 17.

How to Use Double Rod Cylinder Drawing Dimensions

To determine the dimensions for a double rod cylinder, first refer to the desired mounting style of the single rod version, as seen in the preceding pages of this catalog. When you have the required dimensions from that drawing, return to this page to supplement and replace the single rod dimensions with those shown on the double rod drawing and table above. Note that double rod cylinders have a head at both ends and that dimension LD replaces LB, and LGK replaces LG. The double rod dimensions differ from, or are in addition to those for single rod cylinders shown on

preceding pages and provide the information needed to completely dimension a double rod cylinder. In the table above, please note the minimum stroke length per mounting style¹.

On a double rod cylinder where the two rod ends are different, be sure to clearly state which rod end is to be assembled at which end. Port position 1 is standard. If other than standard, specify position 2, 3 or 4 when viewed from rod end #1 only. See port position information on page 49.

Rod End Accessories

Rod end accessories include Rod Clevises, Eye Brackets, Knuckles, Clevis Brackets and Pivot Pins. To identify the proper part number for the desired accessory, please see the table below and find the row of the cylinder's rod end thread size. The part numbers for Pivot Pins, Eye Brackets and Clevis Brackets are listed in the same row as the pin diameter that fits their mating Rod Clevises or Knuckles.

Accessory Load Capacity

The various accessories on this and the following pages have been load rated for your convenience. The load capacity, shown in the table below, is the recommended maximum load for that accessory based on a 4:1 design factor in tension. (Pivot Pin is rated in shear.) Before specifying, compare the actual load or the tension (pull) force at maximum operating pressure of the cylinder with the load capacity of the accessory that you plan to use. If load or pull force of cylinder exceeds load capacity of accessory, consult factory.

Thread Size	Pin Ø	Rod Clevis		Mounting Plate/Eye Bracket		Pivot Pin	
		Part Number	Load Capacity (lb)	Fabricated Steel		Part Number	Shear Capacity (lb)
				Part Number	Load Capacity (lb)		
5/16-24	0.31	0512210000 ¹	2600	0740770000	1700	—	—
7/16-20	0.50	0509400000	4250	0691950000	4100	0683680000	8600
1/2-20	0.50	0509410000	4900	0691950000	4100	0683680000	8600
3/4-16	0.75	0509420000	11200	0691960000	10500	0683690000	19300
3/4-16	0.75	1332840000	11200	0691960000	10500	0683690000	19300
7/8-14	1.00	0509430000	18800	0853610000 ²	20400	0683700000	34300
1-14	1.00	0509440000	19500	0853610000 ²	20400	0683700000	34300
1-14	1.00	1332850000	19500	0853610000 ²	20400	0683700000	34300
1 1/4-12	1.38	0509450000	33500	0691980000	21200	0683710000	65000
1 1/4-12	1.38	1332860000	33500	0691980000	21200	0683710000	65000
1 1/2-12	1.75	0509460000	45600	0853620000 ²	43300	0683720000	105200
1 3/4-12	2.00	0509470000	65600	0853630000 ²	70000	0683730000	137400
1 7/8-12	2.00	0509480000	65600	0853630000 ²	70000	0683730000	137400
2 1/4-12	2.50	0509490000	98200	0853640000 ²	94200	0683740000	214700
2 1/2-12	3.00	0509500000	98200	0853650000 ²	121900	0683750000	309200
2 3/4-12	3.00	0509510000	98200	0853650000 ²	121900	0683750000	309200
3 1/4-12	3.50	0509520000	156700	0735380000	57400	0735450000	420900
3 1/2-12	4.00	0509530000	193200	0735390000	75000	0735470000	565800
4-12	4.00	0509540000	221200	0735390000	75000	0735470000	565800

¹ Includes pivot pin

² Cylinder accessory dimensions conform to ANSI/NFPA/T3.6.8 R1-1984



Rod Clevis Dimensions

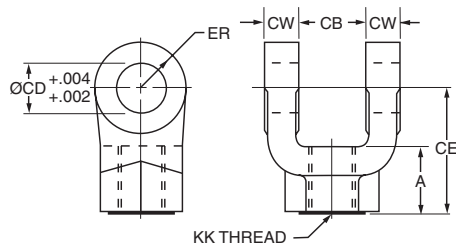

Part Number	Pin \varnothing	A	CB	CD \varnothing	CE	CW	ER	KK Thread
0512210000 ¹	0.31	0.81	0.34	0.313	2.25	0.20	0.30	5/16-24
0509400000	0.50	0.75	0.77	0.500	1.50	0.49	0.50	7/16-20
0509410000	0.50	0.75	0.77	0.500	1.50	0.49	0.50	1/2-20
0509420000	0.75	1.13	1.27	0.750	2.13	0.62	0.75	3/4-16
1332840000	0.75	1.13	1.27	0.750	2.38	0.62	0.75	3/4-16
0509430000	1.00	1.63	1.52	1.000	2.94	0.74	1.00	7/8-14
0509440000	1.00	1.63	1.52	1.000	2.94	0.74	1.00	1-14
1332850000	1.00	1.63	1.52	1.000	3.13	0.74	1.00	1-14
0509450000	1.38	1.88	2.04	1.375	3.75	0.99	1.38	1 1/4-12
1332860000	1.38	2.00	2.04	1.375	4.13	0.99	1.38	1 1/4-12
0509460000	1.75	2.25	2.54	1.750	4.50	1.24	1.75	1 1/2-12
0509470000	2.00	3.00	2.54	2.000	5.50	1.24	2.00	1 3/4-12
0509480000	2.00	3.00	2.54	2.000	5.50	1.24	2.00	1 7/8-12
0509490000	2.50	3.50	3.04	2.500	6.50	1.49	2.50	2 1/4-12
0509500000	3.00	3.50	3.04	3.000	6.75	1.49	2.75	2 1/2-12
0509510000	3.00	3.50	3.04	3.000	6.75	1.49	2.75	2 3/4-12
0509520000	3.50	3.50 ²	4.04	3.500	7.75	1.98	3.50	3 1/4-12
0509530000	4.00	4.00 ²	4.54	4.000	8.81	2.23	4.00	3 1/2-12
0509540000	4.00	4.00 ²	4.54	4.000	8.81	2.23	4.00	4-12

¹ Includes Pivot Pin

² Consult appropriate cylinder rod end dimensions for compatibility.

Pivot Pin Dimensions

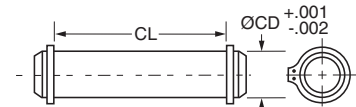

Part Number	CD \varnothing	CL
0683680000	0.500	1.88
0683690000	0.750	2.63
0683700000	1.000	3.13
0683710000	1.375	4.13
0683720000	1.750	5.19
0683730000	2.000	5.19
0683740000	2.500	6.19
0683750000	3.000	6.25
0735450000	3.500	8.25
0735470000 ³	4.000	9.00

³This size supplied with cotter pins.

Note:

1. Pivot Pins are furnished with BB Mount cylinders as standard.
2. Pivot Pins are furnished with (2) Retaining Rings (except as noted).
3. Pivot Pins must be ordered as a separate item if to be used with Knuckles, Rod Clevises, or Clevis Brackets.

Fabricated Steel Mounting Plate/Eye Bracket Dimensions⁴

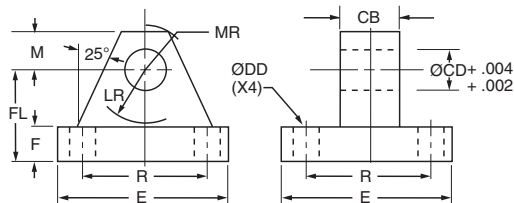

Fabricated Steel Part Number	Pin \varnothing	CB	CD \varnothing	DD \varnothing	E	F	FL	LR	M	MR	R	For Use With BB Mount Per Bore:
0740770000	0.31	0.31	0.313	0.27	2.25	0.38	1.00	0.63	0.38	0.50	1.75	-
0691950000	0.50	0.75	0.500	0.41	2.50	0.38	1.13	0.75	0.50	0.56	1.63	1.50
069196000M	0.75	1.06	0.750	0.53	3.50	0.63	1.88	1.25	0.75	0.88	2.55	2.00
0691960000	0.75	1.25	0.750	0.53	3.50	0.63	1.88	1.25	0.75	0.88	2.55	2.50
0853610000	1.00	1.50	1.000	0.66	4.50	0.88	2.38	1.50	1.00	1.25	3.25	3.25
0691980000	1.38	2.00	1.375	0.66	5.00	0.88	3.00	2.13	1.38	1.63	3.82	4.00
0853620000	1.75	2.50	1.750	0.91	6.50	1.13	3.38	2.25	1.75	2.13	4.95	5.00
0853630000	2.00	2.50	2.000	1.06	7.50	1.50	4.00	2.50	2.00	2.44	5.73	6.00
0853640000	2.50	3.00	2.500	1.19	8.50	1.75	4.75	3.00	2.50	3.00	6.58	7.00
0853650000	3.00	3.00	3.000	1.31	9.50	2.00	5.25	3.25	2.75	3.25	7.50	8.00
0735380000	3.50	4.00	3.500	1.81	12.63	1.69	5.69	4.00	3.50	4.13	9.62	-
0735390000	4.00	4.50	4.000	2.06	14.88	1.94	6.44	4.50	4.00	5.25	11.45	-

⁴ When used to mate with the Rod Clevis, select by Pivot Pin diameter in the table on the prior page.

Rod End Accessories

Rod end accessories include Rod Clevises, Eye Brackets, Knuckles, Clevis Brackets and Pivot Pins. To identify the proper part number for the desired accessory, please see the table below and find the row of the cylinder's rod end thread size. The part numbers for Pivot Pins, Eye Brackets and Clevis Brackets are listed in the same row as the pin diameter that fits their mating Rod Clevises or Knuckles.

Accessory Load Capacity

The various accessories have been load rated for your convenience. The load capacity, shown in the table below, is the recommended maximum load for that accessory based on a 4:1 design factor in tension. (Pivot Pin is rated in shear.) Before specifying, compare the actual load or the tension (pull) force at the maximum operating pressure of the cylinder with the load capacity of the accessory you plan to use. If load or pull force of cylinder exceeds load capacity of accessory, consult factory.

Thread Size	Pin Ø	Knuckle		Clevis Bracket		Pivot Pin	
		Part Number	Load Capacity (lb)	Fabricated Steel		Part Number	Shear Capacity (lb)
				Part Number	Load Capacity (lb)		
5/16-24	0.44	0740750000	3300	0740760000	3600	0740780000	6600
7/16-20	0.50	0690890000	5000	0692050000	7300	0683680000	8600
1/2-20	0.50	0690900000	5700	0692050000	7300	0683680000	8600
3/4-16	0.75	0690910000	12100	0692060000	10880	0683690000	19300
7/8-14	1.00	0690920000	13000	0692070000	15180	0683700000	34300
1-14	1.00	0690930000	21700	0692070000	15180	0683700000	34300
1 1/4-12	1.38	0690940000	33500	0692080000	23560	0683710000	65000
1 1/2-12	1.75	0690950000	45000	0692090000	21520	0683720000	105200
1 3/4-12	2.00	0690960000	53500	0692100000	26000	0692150000	137400
1 7/8-12	2.00	0690970000	75000	0692100000	26000	0692150000	137400
2 1/4-12	2.50	0690980000	98700	0692110000	28710	0683740000	214700
2 1/2-12	3.00	0690990000	110000	0692120000	28190	0683750000	309200
2 3/4-12	3.00	0691000000	123300	0692130000	31390	0692160000	309200
3 1/4-12	3.50	0735360000	161300	0735420000	80250	0735450000	420900
3 1/2-12	3.50	0734370000	217300	0735420000	80250	0735450000	420900
4-12	4.00	0734380000	273800	0735430000	98420	0821810000	565800
4 1/2-12	4.00	0734390000	308500	0735440000	108400	0735470000 ¹	565800

¹This size supplied with cotter pins.

Knuckle Dimensions

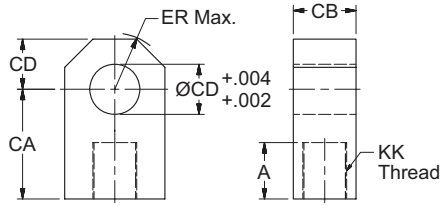

For KK thread sizes 1-7/8"-12 to 4"-12

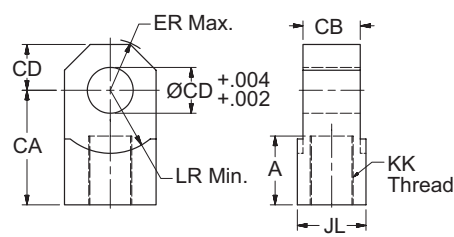

Pivot Pin Dimensions

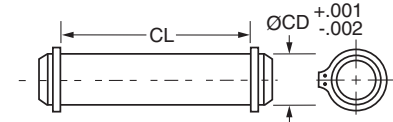

Part Number	Pin Ø	A	CA	CB	CD Ø	ER	JL	KK Thread	LR min
0740750000	0.44	0.75	1.50	0.44	0.438	0.53	-	5/16-24	-
0690890000	0.50	0.75	1.50	0.75	0.500	0.59	-	7/16-20	-
0690900000	0.50	0.75	1.50	0.75	0.500	0.59	-	1/2-20	-
0690910000	0.75	1.13	2.06	1.25	0.750	0.87	-	3/4-16	-
0690920000	1.00	1.13	2.38	1.50	1.000	1.15	-	7/8-14	-
0690930000	1.00	1.63	2.81	1.50	1.000	1.15	-	1-14	-
0690940000	1.38	2.00	3.44	2.00	1.375	1.55	-	1 1/4-12	-
0690950000	1.75	2.25	4.00	2.50	1.750	1.96	-	1 1/2-12	-
0690960000	2.00	2.25	4.38	2.50	2.000	2.24	-	1 3/4-12	-
0690970000	2.00	3.00	5.00	2.50	2.000	2.24	3.00	1 7/8-12	2.77
0690980000	2.50	3.50	5.81	3.00	2.500	2.76	3.50	2 1/4-12	3.09
0690990000	3.00	3.50	6.13	3.00	3.000	3.30	4.00	2 1/2-12	3.58
0691000000	3.00	3.63	6.50	3.50	3.000	3.30	4.00	2 3/4-12	3.58
0735360000	3.50	4.50	7.63	4.00	3.500	3.87	6.00	3 1/4-12	4.18
0734370000	3.50	5.00	7.63	4.00	3.500	3.87	6.00	3 1/2-12	4.18
0734380000	4.00	5.50	9.13	4.50	4.000	4.43	6.00	4-12	4.80
0734390000	4.00	5.50	9.13	5.00	4.000	4.43	-	4 1/2-12	-

Part Number	CD Ø	CL
0740780000	0.438	1.31
0683680000	0.500	1.88
0683690000	0.750	2.63
0683700000	1.000	3.13
0683710000	1.375	4.13
0683720000	1.750	5.19
0692150000	2.000	5.69
0683740000	2.500	6.19
0683750000	3.000	6.25
0692160000	3.000	6.75
0735450000	3.500	8.25
0821810000	4.000	8.63
0735470000 ¹	4.000	9.00

¹ This size supplied with cotter pins.

Note:

1. Pivot Pins are furnished with BB Mount cylinders as standard.
2. Pivot Pins are furnished with (2) Retaining Rings (except as noted).
3. Pivot Pins must be ordered as a separate item if to be used with Knuckles, Rod Clevises, or Clevis Brackets.

Fabricated Steel Clevis Bracket Dimensions²

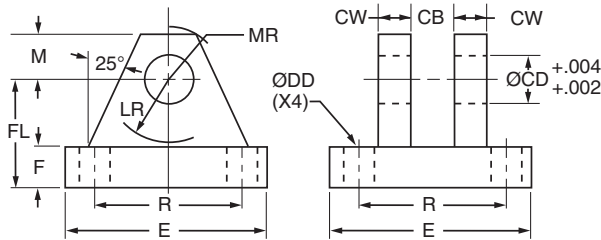

Fabricated Steel Part Number	Pin Ø	CB	CD Ø	CW	DD Ø	E	F	FL	LR	M	MR	R	For Use With B Mount Per Bore:
0740760000	0.44	0.46	0.438	0.38	0.27	2.25	0.38	1.00	0.63	0.38	0.50	1.75	-
0692050000	0.50	0.80	0.500	0.50	0.41	3.50	0.50	1.50	0.75	0.50	0.63	2.55	1.50
0692060000	0.75	1.30	0.750	0.63	0.53	5.00	0.63	1.88	1.19	0.75	0.91	3.82	2.00, 2.50
0692070000	1.00	1.59	1.000	0.75	0.66	6.50	0.75	2.25	1.50	1.00	1.25	4.95	3.25
0692080000	1.38	2.09	1.375	1.00	0.66	7.50	0.88	3.00	2.00	1.38	1.66	5.73	4.00
0692090000	1.75	2.59	1.750	1.25	0.91	9.50	0.88	3.63	2.75	1.75	2.22	7.50	5.00
0692100000	2.00	2.59	2.000	1.50	1.06	12.75	1.00	4.25	3.19	2.25	2.78	9.40	6.00
0692110000	2.50	3.09	2.500	1.50	1.19	12.75	1.00	4.50	3.50	2.50	3.13	9.40	7.00
0692120000	3.00	3.09	3.000	1.50	1.31	12.75	1.00	6.00	4.25	3.00	3.59	9.40	8.00
0692130000	3.00	3.59	3.000	1.50	1.31	12.75	1.00	6.00	4.25	3.00	3.59	9.40	-
0735420000	3.50	4.09	3.500	2.00	1.81	15.50	1.69	6.69	5.00	3.50	4.13	12.00	-
0735430000	4.00	4.59	4.000	2.00	2.06	17.50	1.94	7.69	5.75	4.00	4.88	13.75	-
0735440000	4.00	5.09	4.000	2.00	2.06	17.50	1.94	7.69	5.75	4.00	4.88	13.75	-

² When used to mate with the Knuckle, select by Pivot Pin diameter in the table on the prior page.

Notes

B

Accessories for spherical bearing mount cylinders include Spherical Rod Eyes, Pivot Pins and Clevis

Brackets. To identify the proper part number for the desired accessory, please see the tables below.

**Spherical Rod Eye
(Inch Sizes)**

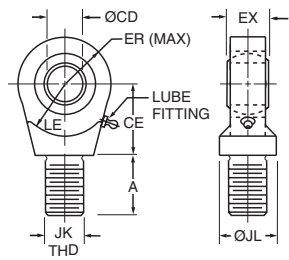

Note: Standard spherical bearing is maintenance-free (sealed) for CDØ > 0.5000"

Bore Ø	Part No.	A	CD Ø +.0000 -.0005	CE	ER	EX	JK Thread Size	JL Ø	LE	Load Capacity (lb)
1.50	1322900000	0.69	0.5000	0.88	0.84	0.44	7/16-20	0.88	0.78	2644
2.00	1322910000	1.00	0.7500	1.25	1.19	0.66	3/4-16	1.31	1.06	9441
2.50										
3.25	1322920000	1.50	1.0000	1.88	1.28	0.88	1-14	1.50	1.44	16860
4.00	1322930000	2.00	1.3750	2.13	1.72	1.19	1 1/4-12	2.00	1.51	28562
5.00	1322940000	2.13	1.7500	2.50	2.09	1.53	1 1/2-12	2.25	2.16	43005
6.00	1322950000	2.88	2.0000	2.75	2.53	1.75	1 7/8-12	2.75	2.50	70193

**Spherical Rod Eye
(Metric Sizes)**

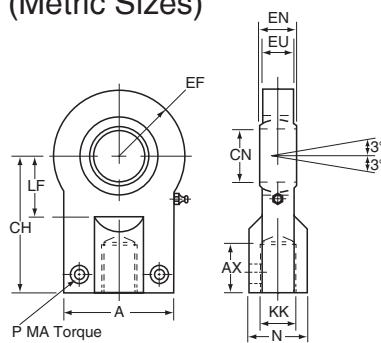

Note: Standard spherical bearing is maintenance-free (sealed)

Part No.	A max	AX min	CH	CN	EF max	EN	EU	KK	LF min	MA max Nm	N max	P	Load Cap. (lb)
1452540000	40	15	42	12 -0.008	20	10 -.012	8	M10x1.25	16	10	17	M6	1798
1452550000	45	17	48	16 -0.008	22.5	14 -.012	11	M12x1.25	20	10	21	M6	2810
1452560000	55	19	58	20 -0.012	27.5	16 -.012	13	M14x1.5	25	25	25	M8	4496
1452570000	62	23	68	25 -0.012	32.5	20 -.012	17	M16x1.5	30	25	30	M8	7194
1452580000	80	29	85	30 -0.012	40	22 -.012	19	M20x1.5	35	45	36	M10	11240
1452590000	90	37	105	40 -0.012	50	28 -.012	23	M27x2	45	45	45	M10	17985
1452600000	105	46	130	50 -0.012	62.5	35 -.012	30	M33x2	58	80	55	M12	28101
1452610000	134	57	150	60 -0.015	80	44 -.015	38	M42x2	68	160	68	M16	44962
1452620000	156	64	185	80 -0.015	102.5	55 -.015	47	M48x2	92	310	90	M20	71939
1452630000	190	86	240	100 -0.020	120	70 -.020	57	M64x3	116	530	110	M24	112404

Pivot Pin (Inch Sizes)

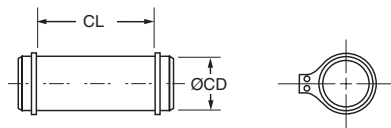

Pivot Pins are furnished with (2) Retainer Rings.

Bore Ø	Part No.	CD Ø	CL	Shear Capacity (lb)
1.50	0839620000	.4997 -.0004	1.56	8600
2.00	0839630000	.7497 -.0005	2.03	19300
2.50				
3.25	0839640000	.9997 -.0005	2.50	34300
4.00	0839650000	1.3746 -.0006	3.31	65000
5.00	0839660000	1.7496 -.0006	4.22	105200
6.00	0839670000	1.9996 -.0007	4.94	137400

Clevis Bracket for SB Mount Cap or Spherical Rod Eye (Inch Sizes)

Fabricated Steel

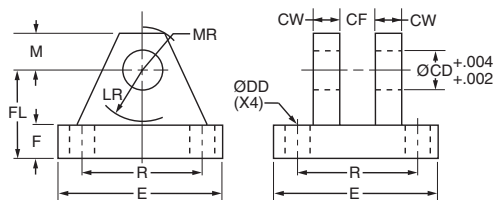

Bore Ø	Fabricated Steel Part Number	CD Ø	CF	CW	DD Ø	E	F	FL	LR	M	MR	R	Load Capacity (lb)
1.50	0839470000	0.500	0.45	0.50	0.41	3.00	0.50	1.50	0.94	0.50	0.63	2.05	5770
2.00	0839480000	0.750	0.67	0.63	0.53	3.75	0.63	2.00	1.38	0.88	1.00	2.76	9450
2.50													
3.25	0839490000	1.000	0.89	0.75	0.53	5.50	0.75	2.50	1.69	1.00	1.19	4.10	14300
4.00	0839500000	1.375	1.20	1.00	0.66	6.50	0.88	3.50	2.44	1.38	1.63	4.95	20322
5.00	0839510000	1.750	1.55	1.25	0.91	8.50	1.25	4.50	2.88	1.75	2.06	6.58	37800
6.00	0839520000	2.000	1.77	1.50	0.91	10.63	1.50	5.00	3.31	2.00	2.38	7.92	50375

Linear Alignment Couplers are available in 19 standard thread sizes

Cost Saving Features and Benefits Include:

- Maximize reliability for trouble-free operation, long life and lower operating costs
- Increase cylinder life by reducing wear on piston and rod bearings
- Simplify cylinder installation and reduce assembly costs
- Lower maintenance costs from possible machine misalignment

Alignment Coupler

See Table for Part Numbers and Dimensions

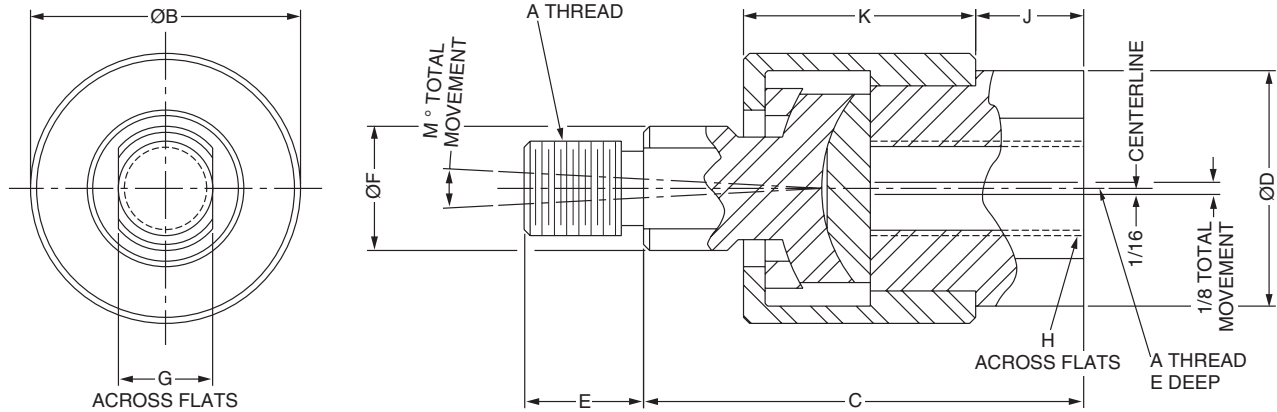

Part Numbers and Dimensions

Part No.	A ¹ Thread Size	B Ø	C	D Ø	E	F Ø	G	H	J	K	M	Max. Pull Load (lbs.)	Max. Approx. Weight (lbs.)
1347570031	5/16-24	1.13	1.75	0.94	0.50	0.50	0.38	0.75	0.38	0.94	6°	1200	.35
1347570038	3/8-24	1.13	1.75	0.94	0.50	0.50	0.38	0.75	0.38	0.94	6°	2425	.35
1347570044	7/16-20	1.38	2.00	1.13	0.75	0.63	0.50	0.88	0.38	1.09	6°	3250	.55
1347570050	1/2-20	1.38	2.00	1.13	0.75	0.63	0.50	0.88	0.38	1.09	6°	4450	.55
1347570063	5/8-18	1.38	2.00	1.13	0.75	0.63	0.50	0.88	0.38	1.09	6°	6800	.55
1347570075	3/4-16	2.00	2.31	1.63	1.13	0.94	0.75	1.31	0.44	1.28	6°	9050	1.4
1347570088	7/8-14	2.00	2.31	1.63	1.13	0.94	0.75	1.31	0.44	1.28	6°	14450	1.4
1347570100	1-14	3.13	3.00	2.38	1.63	1.44	1.25	1.88	0.75	1.78	6°	19425	4.8
1347570125	1 1/4-12	3.13	3.00	2.38	1.63	1.44	1.25	1.88	0.75	1.78	6°	30500	4.8
1337390125	1 1/4-12	3.50	4.00	2.00	2.00	1.50	1.25	1.69	0.75	2.50	10°	30500	6.9
1337390150	1 1/2-12	4.00	4.38	2.25	2.25	1.75	1.50	1.94	0.88	2.75	10°	45750	9.8
1337390175	1 3/4-12	4.00	4.38	2.25	2.25	1.75	1.50	1.94	0.88	2.75	10°	58350	9.8
1337390188	1 7/8-12	5.00	5.63	3.00	3.00	2.25	1.94	2.63	1.38	3.38	10°	67550	19.8
1337390200	2-12	5.00	5.63	3.00	3.00	2.25	1.94	2.63	1.38	3.38	10°	77450	19.8
1337390225	2 1/4-12	6.75	6.38	3.25	3.50	2.75	2.38	2.88	1.63	3.75	10°	99250	35.3
1337390250	2 1/2-12	7.00	6.50	4.00	3.50	3.25	2.88	3.38	1.63	3.88	10°	123750	45.3
1337390275	2 3/4-12	7.00	6.50	4.00	3.50	3.25	2.88	3.38	1.63	3.88	10°	150950	45.3
1337390300	3-12	7.00	6.50	4.00	3.50	3.25	2.88	3.38	1.63	3.88	10°	180850	45.3
1337390325	3 1/4-12	9.25	8.50	5.25	4.50	4.00	3.38	4.50	2.00	5.50	10°	218450	-
1337390425	4 1/4-12	12.88	11.25	7.75	4.50	5.50	4.88	7.00	1.50	8.75	10°	370850	-

¹ Metric thread size couplers are also available, please consult factory.

How to Order Linear Alignment Couplers — When ordering a cylinder with a threaded male rod end, specify the coupler of equal thread size by part number as listed in the table. For example, Piston Rod “KK” or “CC” dimension is 3/4"-16, specify coupler part number 1347570075.

Style 55 Piston Rod End
Split Couplers and Weld Plates

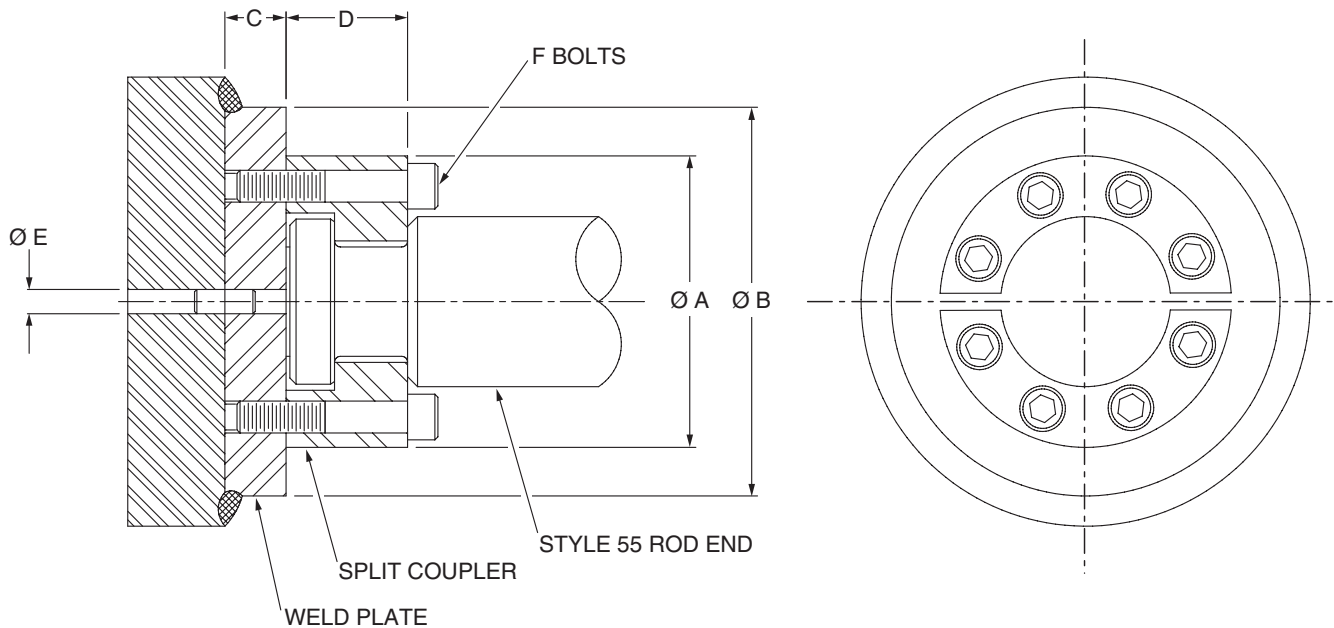

⚠ WARNING: Piston rod separation from the machine member can result in severe personal injury or even death to nearby personnel. The cylinder user must make sure the weld holding the weld plate to the machine is of sufficient quality and size to hold the intended load. The cylinder user must also make sure the bolts holding split coupler to the weld plate are of sufficient strength to hold the intended load and installed in such a way that they will not become loose during the machine's operation.

Part Numbers and Dimensions

Rod Ø	A Ø	B Ø	C	D	E Ø	F	Bolt Size	Bolt Circle	Split Coupler Part No.	Weld Plate Part No.
0.625	1.50	2.00	0.50	0.56	.250	4	#10-24 x .94 LG	1.125	1472340062	1481740062
1.000	2.00	2.50	0.50	0.88	.250	6	1/4-20 x 1.25 LG	1.500	1472340100	1481740100
1.375	2.50	3.00	0.63	1.00	.250	6	5/16-18 x 1.00 LG	2.000	1472340138	1481740138
1.750	3.00	4.00	0.63	1.25	.250	8	5/16-18 x 1.75 LG	2.375	1472340175	1481740175
2.000	3.50	4.00	0.75	1.63	.375	12	3/8-16 x 2.25 LG	2.687	1472340200	1481740200
2.500	4.00	4.50	0.75	1.88	.375	12	3/8-16 x 2.50 LG	3.187	1472340250	1481740250
3.000	5.00	5.50	1.00	2.38	.375	12	1/2-13 x 3.25 LG	4.000	1472340300	1481740300
3.500	5.88	7.00	1.00	2.63	.375	12	5/8-11 x 3.50 LG	4.687	1472340350	1481740350
4.000	6.38	7.00	1.00	2.63	.375	12	5/8-11 x 3.50 LG	5.187	1472340400	1481740400
4.500	6.88	8.00	1.00	3.13	.375	12	5/8-11 x 4.00 LG	5.687	1472340450	1481740450
5.000	7.38	8.00	1.00	3.13	.375	12	5/8-11 x 4.00 LG	6.187	1472340500	1481740500
5.500	8.25	9.00	1.25	3.88	.375	12	3/4-10 x 5.00 LG	6.875	1472340550	1481740550

Note: Bolts are not included with split coupler or weld plate

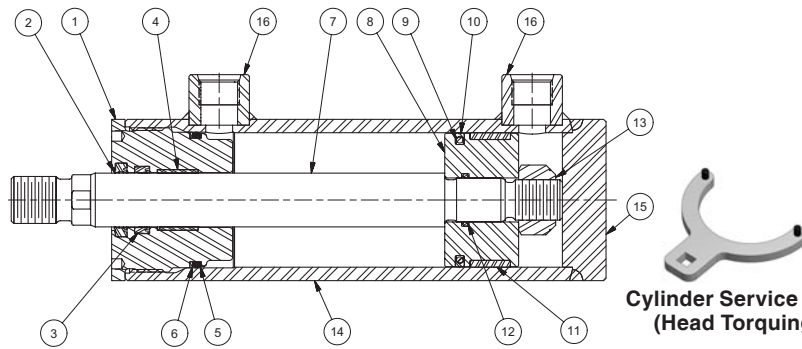

Cylinder Service Tool (Head Torquing)

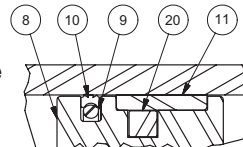

Optional Magnetic Piston

Notes:

Factory assembled piston rod assemblies (which include seals for the specified piston type) are recommended. Do not remove the piston from the rod.

Cylinders rated for high temperatures (Seal Codes V, H and D) may include a set screw to lock the head to the cylinder body. Please remove and replace when servicing the cylinder.

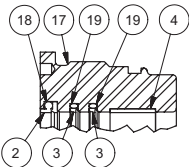

Optional Extreme High Temperature and Low Friction Head

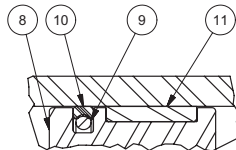

Optional Hi Load and Low Friction Piston (Bronze Filled PTFE Seal)

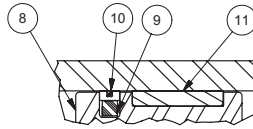

Optional Mixed Media Piston

Symbol	Description
1	Head
2	Rod wiper
3	Rod seal
4	Rod wear ring ¹
5	End seal (o-ring)
6	Backup ring for end seal
7	Piston rod (single rod type)
8	Piston
9	Piston seal energizer
10	Piston seal
11	Piston wear ring
12	Piston joint o-ring
13	Piston rod nut ²
14	Cylinder body (welded to cap)
15	Cap (welded to cylinder body)
16	Port (welded to cylinder body)
17	Head (optional) ³
18	Rod wiper energizer ^{3,4}
19	Rod seal energizer ³
20	Magnetic rings ⁵

¹ Not used for 0.625" rod diameter

² Only for 1.50" to 5.00" bores. For 6.00" to 8.00" bores, pistons are threaded and torqued to the piston rod, and set screws are used to lock the piston to the rod.

³ Used for Piston code F or Seal code H

⁴ Used for Seal codes M and D

⁵ Used for Piston code 7

Bore Ø	Rod No.	Rod Ø	Complete Cylinder Service Kit ⁶				Spanner Hole Ø	Cylinder Service Tool ⁷	Head Torque Units	
			Includes all appropriate seals, backup rings and wear rings (2, 3, 4, 5, 6, 9, 10 and 11)						USA Lb-Ft	Metric N-m
			For Class 1 Service with:							
			Standard (B) or Magnetic Piston (7)	Hi Load Piston (K)	Low Friction Seals (F)	Mixed Media Piston (W)	2 holes on head face ⁷	Fits standard square drive on torque wrench		
1.50	1	0.625	SK151RDH01	SK151RDHK1	SK151RDHF1	SK151RDHW1	0.125	RDHSVCTL15	55	75
	2	1.000	SK152RDH01	SK152RDHK1	SK152RDHF1	SK152RDHW1				
2.00	1	1.000	SK201RDH01	SK201RDHK1	SK201RDHF1	SK201RDHW1	0.125	RDHSVCTL20	70	95
	2	1.375	SK202RDH01	SK202RDHK1	SK202RDHF1	SK202RDHW1				
2.50	1	1.000	SK251RDH01	SK251RDHK1	SK251RDHF1	SK251RDHW1	0.188	RDHSVCTL25	100	136
	2	1.750	SK252RDH01	SK252RDHK1	SK252RDHF1	SK252RDHW1				
	3	1.375	SK253RDH01	SK253RDHK1	SK253RDHF1	SK253RDHW1				
3.25	1	1.375	SK321RDH01	SK321RDHK1	SK321RDHF1	SK321RDHW1	0.250	RDHSVCTL32	150	203
	2	2.000	SK322RDH01	SK322RDHK1	SK322RDHF1	SK322RDHW1				
	3	1.750	SK323RDH01	SK323RDHK1	SK323RDHF1	SK323RDHW1				
4.00	1	1.750	SK401RDH01	SK401RDHK1	SK401RDHF1	SK401RDHW1	0.250	RDHSVCTL40	175	237
	2	2.500	SK402RDH01	SK402RDHK1	SK402RDHF1	SK402RDHW1				
	3	2.000	SK403RDH01	SK403RDHK1	SK403RDHF1	SK403RDHW1				
5.00	1	2.000	SK501RDH01	SK501RDHK1	SK501RDHF1	SK501RDHW1	0.250	RDHSVCTL50	225	305
	2	3.500	SK502RDH01	SK502RDHK1	SK502RDHF1	SK502RDHW1				
	3	2.500	SK503RDH01	SK503RDHK1	SK503RDHF1	SK503RDHW1				
6.00	1	2.500	SK601RDH01	SK601RDHK1	SK601RDHF1	SK601RDHW1	0.281	RDHSVCTL60	285	386
	2	4.000	SK602RDH01	SK602RDHK1	SK602RDHF1	SK602RDHW1				
	3	3.000	SK603RDH01	SK603RDHK1	SK603RDHF1	SK603RDHW1				
7.00	1	3.000	SK701RDH01	SK701RDHK1	SK701RDHF1	SK701RDHW1	0.375	RDHSVCTL70	400	542
	2	5.000	SK702RDH01	SK702RDHK1	SK702RDHF1	SK702RDHW1				
	3	4.000	SK703RDH01	SK703RDHK1	SK703RDHF1	SK703RDHW1				
8.00	1	3.500	SK801RDH01	SK801RDHK1	SK801RDHF1	SK801RDHW1	0.531	RDHSVCTL80	485	658
	2	5.500	SK802RDH01	SK802RDHK1	SK802RDHF1	SK802RDHW1				
	3	4.500	SK803RDH01	SK803RDHK1	SK803RDHF1	SK803RDHW1				

⁶ The service kit numbers shown identify kits for **Class 1 seals**. To order service kits for other seal Classes (2, 3, 4, 5 or 8), substitute that Class number as required for the last digit of the service kit number. Consult factory for other service kits (including double rod end kits).

⁷ Spanner holes do not exist on cylinders with the J Mount and JP Mount; the head mounting holes are used to assemble and disassemble the cylinder. Service tool part numbers for these mounts include a letter "J" at the end of the standard service tool part number. For example, the tool to service a 2.50" bore J Mount cylinder is part number RDHSVCTL25J.

Notes

Water Submersible Option

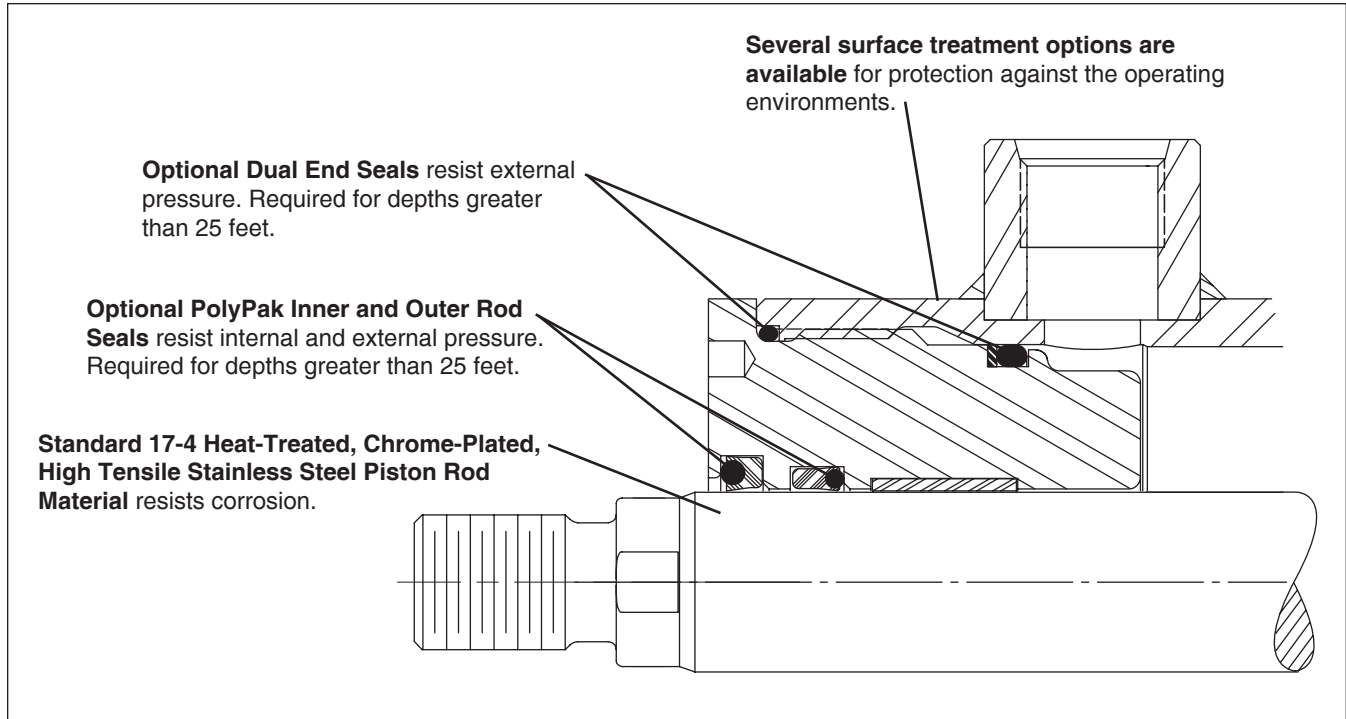

Specifications:

- Submersion Depth – to 15,000 feet
- Nominal Pressure – 3,000 psi
- Operating Temperature – -10°F to +165°F
- 17-4 PH chrome plated stainless steel piston rod
- Stainless steel nametag

Cylinder Seal Construction:

- 0 to 25 feet depth – Standard rod seal and end seals
- 25 to 5,000 feet depth
 - Subsea rod seal package that includes a PolyPak oil seal and an outward-facing PolyPak wiper to seal against water intrusion.
 - Subsea end seal package with ID oil seal and body-end o-ring to seal against water intrusion.
- Over 5,000 feet depth – consult factory for details

Standard Options for Water Submersible Cylinders:

Material

- Chrome plated cylinder body ID

Surface Treatments for Corrosion Protection

- Electroless nickel plated exterior (head, cap and cylinder body)
- Inorganic zinc primer (zinc primer only – without bond coating)
- Inorganic zinc primer with epoxy undercoat and polyurethane or acrylic epoxy topcoat
- Epoxy undercoat and topcoat

Custom Options available for Special Order:

- All stainless steel construction



How to Order Water Submersible Option

Water Submersible Option

How to order:

1. Specify the complete cylinder model number.
2. Put an "S" in the model number to indicate a Special Modification.
3. Include the 3 digit "Submersible Code" (see below).
4. For custom options, provide a complete description or drawing of your requirements.

Submersible Code

When selecting the submersible option, an S must be placed in the Model Number. Select Submersible Code values for the required Submersion Depth, Cylinder Body, and Corrosion Protection. See the example Model Number below:

Feature	Code	Specification	For
Submersion Depth	1	Conventional rod seal, rod wiper and end seal	Depths to 25 feet
	2	Submersible rod seal, rod wiper and end seal	Depths to 5,000 feet
	3	Other	Specify depth / requirements
Cylinder Body	P	Plain cylinder body ID	
	C	Chrome plated cylinder body ID	
Corrosion Protection	1	Inorganic zinc primer	Splash and short term immersion service where equipment is top coated by the customer
	3	Electroless nickel plated exterior	
	4	Inorganic zinc primer, epoxy undercoat, and polyurethane or acrylic epoxy topcoat.	Splash and short term immersion service
	6	Epoxy base and top coat.	Long term immersion service
	9	Other	Specify requirements

Example:

4.00BBRDHKTS14A24.000

S = Submersible Code 2P1

(describes a 4" bore x 24" stroke Series RDH cylinder for submersion up to 5,000 feet, with a plain cylinder body ID and inorganic zinc primer corrosion protection.)

Water Submersible Codes and Features Supplied

Depths to 5,000 feet¹

Submersible Cylinder Feature	Water Submersible Code ¹							
	2P1	2P3	2P4	2P6	2C1	2C3	2C4	2C6
17-4 PH stainless steel piston rod	X	X	X	X	X	X	X	X
Stainless steel nametag	X	X	X	X	X	X	X	X
Submersible rod seal and wiper	X	X	X	X	X	X	X	X
Dual end seals	X	X	X	X	X	X	X	X
Chrome plated cylinder body ID					X	X	X	X
Electroless nickel plated exterior		X				X		
Inorganic zinc primer	X				X			
Inorganic zinc primer with topcoats			X				X	
Epoxy base and topcoat				X				X

¹ Corresponding submersible codes for depths to 25 feet begin with 1 (e.g. 1P1, 1P3, etc.) and include all of the features marked for 5,000 feet depth **except** Submersible Rod Seal, Rod Wiper and End Seals.

The Exclusive Hi Load Piston

**The effective difference...
bronze filled PTFE ring design.**

- Virtually eliminates leakage
- High load capacity
- High contamination tolerance
- Long life
- Low friction

The revolutionary Hi Load piston assembly was designed to increase and insure consistent quality performance of the piston seals and your equipment. It's a major innovative refinement over typical cast iron piston rings and nitrile or fluorocarbon lipseals.

The Hi Load piston assembly overcomes the inherent problems commonly associated with these conventional types of seals, such as scoring of the cylinder bore due to contamination, and it virtually eliminates leakage flow. It can also reduce or eliminate the need for stop tubing. It has much greater side load carrying capacity, and most importantly, even at pressures up to 3,000 psi, it has a longer wearing life than any seal that we have tested to date.

The Hi Load piston assembly is comprised of a bronze filled PTFE piston seal (with a nitrile energizer) and a WearGard™ non-metallic wear ring to achieve dramatic efficiency.

Reduced scoring. Low friction. The WearGard™ non-metallic wear ring eliminates all metal-to-metal contact between the piston and cylinder body. Some scoring may occur even with the use of compatible materials such as cast iron or bronze for the piston and steel for the cylinder body. The combination of the high imbeddability factor and the wiping action of the wear ring prevents contamination from getting between the piston bearing and sealing surfaces; therefore, scoring is greatly reduced and cylinder life is extended. Other benefits of the Hi Load piston are excellent lubricity and minimum wear when using water base fluids, soluble oil & water, or biodegradable fluids.

Extensive controlled contamination tests in our laboratory have shown the Hi Load piston to operate more than **4 times longer** than lip seals when high degrees of contamination are present.

Note: Because the Hi Load piston prevents metal-to-metal contact with the cylinder bore, steel pistons may be used.

Higher side load carrying capacity. Under severe side load conditions arising from long stroke or pivot mounted cylinders, the characteristics of a non-metallic wear ring provide increased side load carrying capability, a distinctive benefit. The non-metallic bearing can also absorb hydraulic shock and conform more to the piston and cylinder body. The action of deformation increases the area of contact, which in turn keeps the contact stresses from increasing and permits the Hi Load piston to have a higher side load carrying capacity. This can often reduce or eliminate the need for stop tubing.

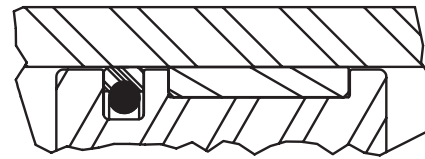

Optional Hi Load Piston

Virtually zero leakage. The Hi Load piston assembly provides virtually zero leakage with hydraulic and/or water base fluids due to the continuous bronze filled PTFE ring with a homogenous inner ring of Nitrile rubber to apply seal preloading. The Nitrile energizer provide enough initial radial force to eliminate low pressure leakage. At higher pressure (above 2,000 psi) the seal is also pressurized underneath, and is therefore dynamically self-sealing.

The bronze filled PTFE resists extrusion in the clearance between the piston and bore much better than Nitrile, and, as a result, increases the life of a cylinder, significantly at higher pressures.

When ordering the Hi Load piston option for Series RDH cylinders, please specify K in the Piston field of the model code.

Comparative Piston Seal Friction

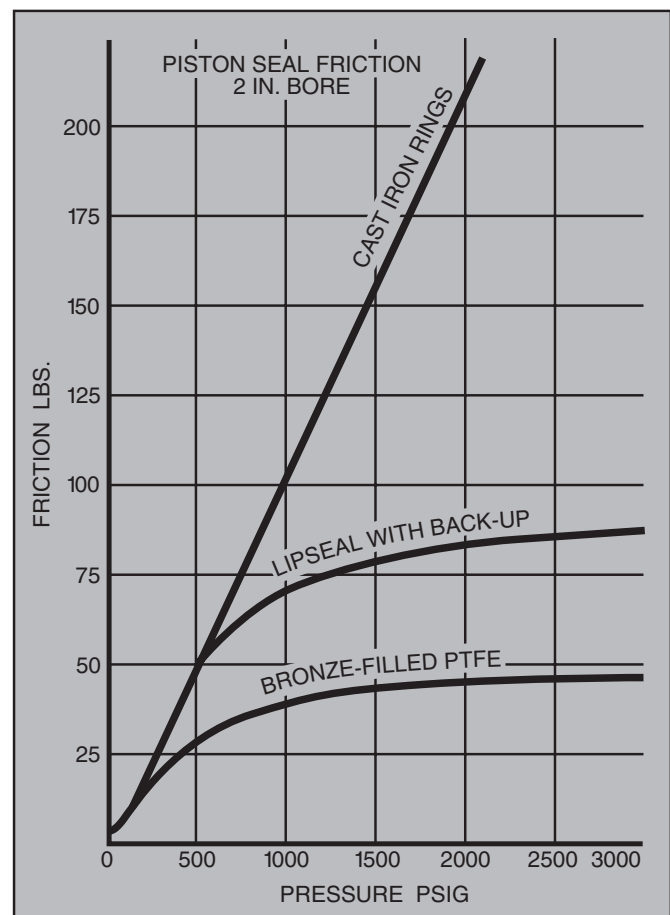

Low Friction Seal Option

- Smooth-running operation – reduces “stick/slip” or “chatter”
- Bronze filled PTFE seals and WearGard™ wear rings for low friction, rapid break-in and long service life

- Appropriate for servo applications
- Innovative seal geometry for maximum sealing efficiency
- When ordering Series RDH cylinders, place an “F” in the Piston field for Low Friction Seals.

Low Friction Rod Seal Design

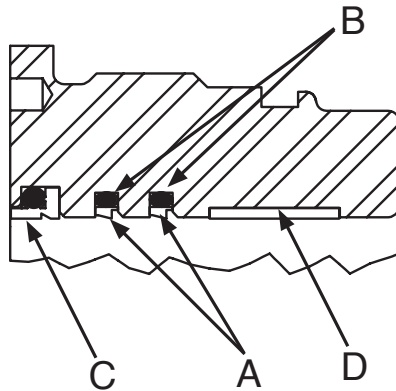

- A** - Dual bronze filled PTFE step-seal rod seals insure positive sealing and smooth operation at low or high pressures.
- B** - Elastomer expander for pressure compensation and low pressure effectiveness.
- C** - Durable, energized bronze filled PTFE lip wiper keeps contaminants out.
- D** - WearGard™ wear ring for high load capacity, low friction and no metal-to-metal contact.

Available for all standard piston rod diameters larger than 0.625"

Low Friction Piston Seal Design

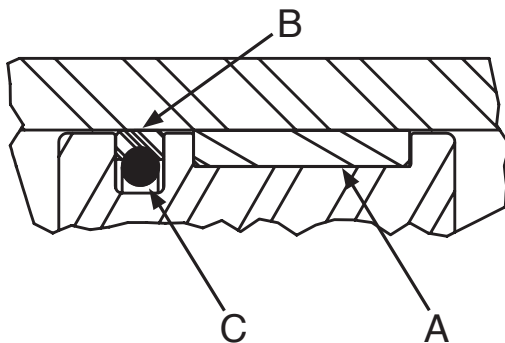

- A** - WearGard™ wear ring for high load capacity, low friction and no metal-to-metal contact.
- B** - Bronze filled PTFE piston seal insures maximum sealing efficiency.
- C** - Elastomer expander for pressure compensation and low pressure effectiveness.

Available for all standard bore diameters.

Seal Friction

Seal friction under a given set of working conditions is not easily calculated due to the multiplicity of variables involved. The following graph is offered as a guide for use in performance calculations, but for critical applications, measurements should be made under simulated or actual working conditions.

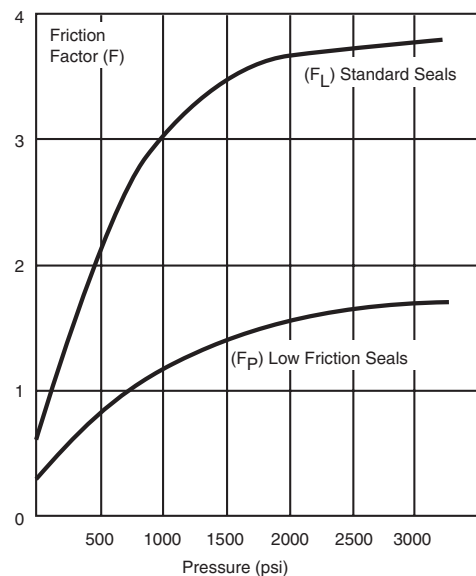

Other Common Modifications

The following modifications can be supplied on most Series RDH cylinders for an additional charge.

Metallic Rod Wiper

When specified, metallic rod wipers can be supplied instead of the standard urethane wiperseal. Recommended in applications where contaminants tend to cling to the extended piston rod and would damage the standard urethane wiperseal. Installation of metallic rod wiper does not affect cylinder dimensions.

Air Bleeds

In most hydraulic circuits, cylinders are considered self-bleeding when cycled full stroke. If air bleeds are required and specified, Air Bleed Ports for venting air can be provided at both ends of the cylinder body, or on the head or cap. To order, specify "Bleed Port" and indicate the desired position on the cylinder.

Rod End Boots

Cylinders have a hardened bearing surface on the piston rod to resist external damage and are equipped with the high efficiency "wiperseal" to remove external dust and dirt. Exposed piston rods that are subjected to contaminants with air hardening properties, such as paint, should be protected. In such applications, the use of a collapsing cover should be considered. This is commonly referred to as a "rod boot". Calculate the longer rod end required to accommodate the collapsed length of the boot from the following data.

LF	.13	.13	.13	.13	.13	.13	.13	.10	.10	.10	.10	.10
OD	2.25	2.25	2.63	3.00	3.38	3.75	4.38	5.13	5.63	6.25	7.00	7.50
MM	.50	.625	1.000	1.380	1.750	2.000	2.500	3.000	3.500	4.000	5.000	5.500

To determine extra length of piston rod required to accommodate boot, calculate:
 $BL = \text{Stroke} \times LF + 1.13"$
 $BL + W + A = \text{length of piston rod to extend beyond the head face.}$
Note: Check all Boot O.D's against "E" dimension from catalog.

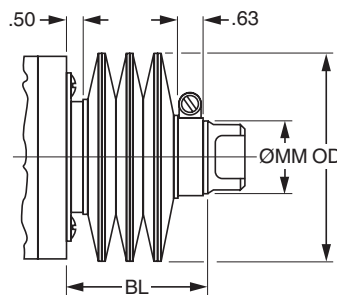

Stroke Adjusters

For the requirement where adjusting the stroke is specified. Several designs are available.

A "retracting stroke adjuster" must be ordered with an S for Special Modification in the model code, and the length of the adjustment must be specified.

"Infrequent-type" is defined by positioning the retract stroke in a couple of attempts at original machine set up. The "frequent-type" stroke adjuster is recommended for adjustments required after the equipment has been adjusted by the original machine manufacturer.

Heavy Duty Hydraulic Roundline Cylinders Common Modifications

Metric Piston Rod Thread

The table below lists the standard thread supplied when Piston Rod Thread Type M is specified in the cylinder model code with Piston Rod Ends 4, 8 and 9. For Style 7M, see page 15 for details.

MM Rod Ø (inches)	Thread Size		A Thread Length (inches)
	Styles 4M & 9M KK	Style 8M CC	
0.625	M10x1.5	M12x1.5	0.75
1.000	M20x1.5	M22x1.5	1.13
1.375	M26x1.5	M30x2	1.63
1.750	M33x2	M39x2	2.00
2.000	M39x2	M45x2	2.25
2.500	M48x2	M56x2	3.00
3.000	M58x2	M68x2	3.50
3.500	M64x2	M76x2	3.50
4.000	M76x2	M95x2	4.00
4.500	M80x2	M110x2	4.50
5.000	M90x2	M110x2	5.00
5.500	M100x2	M130x2	5.50

Rectangular Head and Cap Flanges

Rectangular head flanges and cap flanges that match-mount NFPA Style ME5 and ME6 are available as a special modification. Please enter "S" for Special Modification in the cylinder model code, request the desired flange in the item notes and consult factory for a quote.

Welded Rod End Accessories

Some standard and special rod end accessories can be welded to the piston rod. In the cylinder model code, please specify "3" in the Piston Rod Thread Style field (for special rod end). Then describe the accessory in the item notes (or furnish a dimensioned sketch), signify that it is welded to the piston rod and consult factory for a quote.

Additional common and custom modifications are available, please see the list on page 3 or consult the factory.

Switches Mounted on Series RDH Cylinders Add Value to Your Machine Design

- Switches and cylinder combine to form a compact package
- Body-mounted switches are easily adjustable along cylinder stroke length
- Low profile switches are less prone to mechanical damage
- Non-intrusive design eliminates the possibility of oil leakage
- Utilizes the standard carbon steel cylinder body

Series RDH Cylinder – with magnetic piston

Durable polyurethane bi-directional seal – for positive sealing with no by-pass and long life.

WearGard™ wear ring – improves resistance to bearing loads and provides support for magnet.

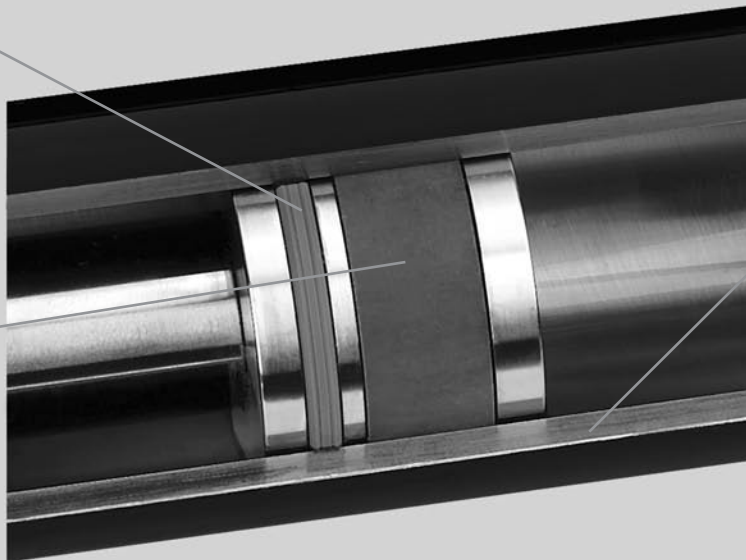

Cylinder Body – Standard carbon steel material for ALS Switch.

C

ALS Switch Wiring and Installation

- For magnetic piston sensing through steel tube material
- 4 wire DC connection
- PNP and NPN versions can be wired N.O. or N.C.

Switch Operation

The switch detects a change in polarity of the magnetic field as a piston with magnet moves through the cylinder.

Formatting

Before the switch is used for the first time, the piston with magnet should be run in and out of the cylinder to format the cylinder tube. The switch will detect the polarity of the residual magnetic field created by the movement of the magnetic piston during formatting.

Field Direction with Magnetic Piston

Single rod end cylinders are assembled with the piston magnet's North Pole facing the rod end. As the magnetic piston moves through the cylinder, it creates a stronger field opposite in polarity to the residual magnetism in the cylinder tube. As it moves under the switch, the change in polarity of the magnetic field in the cylinder tube is detected.

Switch Zone

Switch actuation occurs as the piston enters a switching "zone". The switching point is highly repeatable, in either direction, under conditions of constant piston speed and operating temperature.

Note: ALS Switches are designed to sense near end of stroke positions ("stroke-to-go") and stroke positions in between these two points. For true end-of-stroke position sensing, please use the CLS-2 Limit Switches on page 41.

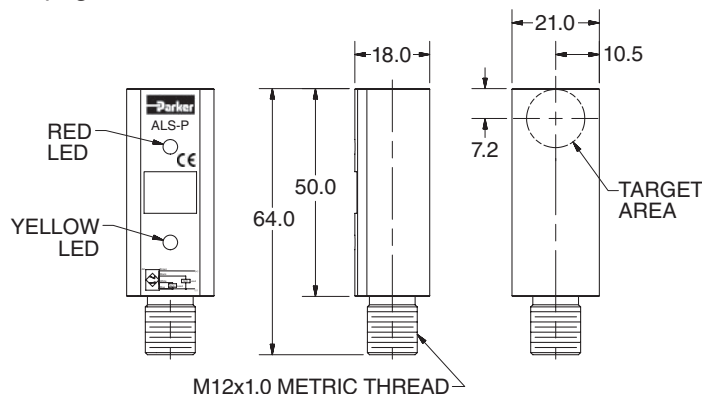

ALS Switch output states may be influenced by an external magnetic field. Care must be taken to avoid external magnetic field exposure.

- The ALS Switch is not designed for use with non-ferrous tubes
- CE approved
- ATEX approved version available

The switching zone may be up to 21mm wide depending on tube wall thickness and piston speed.

LED Indicators

There are two LED's (yellow and red) to indicate that the piston is inside or outside the switching zone. The sequence of the LED's is determined by the orientation of the north pole of the magnet system (rod end side of single rod end cylinders) to the connector.

When the ALS Switch connector faces the rod side of single rod end cylinders the red LED turns ON when the piston is within the switching zone. The yellow LED is ON otherwise.

When the ALS Switch connector faces the cap side of single rod end cylinders the yellow LED turns ON when the piston is within the switching zone. The red LED is ON otherwise.

Performance

ALS Switches have been designed to operate at a maximum piston speed of 0.5m/s, and a maximum cylinder operating temperature of 85°C.

Specifications

Switching Output:	PNP or NPN
Hysteresis¹:	5mm
Repeatability¹:	0.5mm
Load Current:	100mA
Leakage Current:	≤ 10µA
Voltage Drop:	≤ 1.5 VDC
Short Circuit and Overload Protection:	Yes
Reverse Polarity Protection:	Yes
Supply Voltage:	10 - 30 VDC
LED(s):	Yes (2)
Current Consumption:	≤ 30 mA
Operating Temperature Range:	-25°C to +85°C (-13°F to +185°F)
Housing Material:	Black Polyamide (PA)
Enclosure Rating:	IP67

¹Hysteresis and repeatability based on measurements with a cylinder outer diameter of 46mm, wall thickness of 3mm and piston speed of 0.5m/s.

ALS Switch Wiring and Installation

Because the ALS Switch detects change in polarity as the magnet moves through the cylinder, wiring connections are dependent on switch mounting orientation to the magnet's North Pole. The two possible orientations are:

- A – connector facing toward the rod end
(rod end 1 if K-type)
- B – connector facing toward the cap end
(rod end 2 if K-type)

Connections to Pin 1 (+VDC) and Pin 3 (-VDC) are the same for either switch orientation. But, as outlined in the table and wiring schematic diagrams below, the normal output state of Pins 2 & 4 flip between mounting orientations A & B. Note that to sense near the fully retracted position of the cylinder the cap end switch must be mounted in orientation A, and to sense near the fully extended position of the cylinder the rod end switch must be mounted in orientation B.

General view of switches as installed:

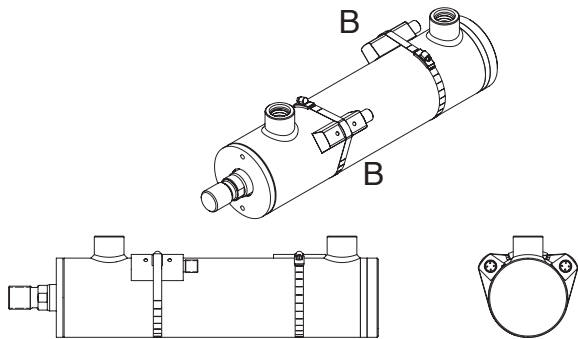

Example: An application requires that ALS Switches sense two positions of the cylinder with normally closed logic at both ends. How would the switches be wired?

Answer: The two switches would not be installed or wired the same way. The cap end switch would be installed in orientation A with Pin 1 (+VDC), Pin 2 (Load), Pin 3 (-VDC), Pin 4 (not used). The rod end switch would be installed in orientation B with Pin 1 (+VDC), Pin 2 (not used), Pin 3 (-VDC), Pin 4 (Load).

LED Function and Pin Wiring

Switch Mounting Orientation	Connector Facing Toward		LED indicator (on/off) when magnet is:				Pin	Wire	Function
	Single Rod Cylinder	Double Rod Cylinder	Out of Switch Zone		In Switch Zone				
			Red	Yellow	Red	Yellow			
A	Rod End	Rod End #1	off	on	on	off	1	Brown	+VDC
			off	on	on	off	2	White	N.C.
			off	on	on	off	3	Blue	-VDC
			off	on	on	off	4	Black	N.O.
B	Cap End	Rod End #2	on	off	off	on	1	Brown	+VDC
			on	off	off	on	2	White	N.O.
			on	off	off	on	3	Blue	-VDC
			on	off	off	on	4	Black	N.C.

PNP

Switch Orientation A

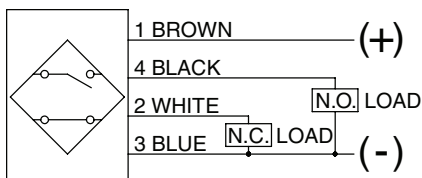

Switch Orientation B

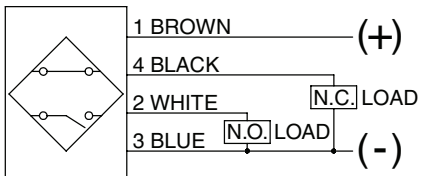

**ALS Switch – Wiring Connection
12mm Connector**

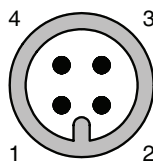

NPN

Switch Orientation A

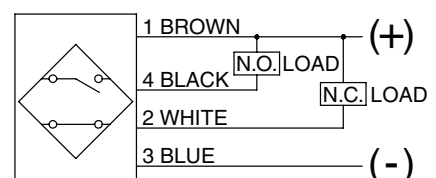

Switch Orientation B

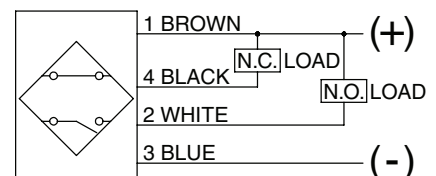

ALS Switch and Accessory Part Numbers

All switches have a 4-pin male M12x1 threaded connector.

Body mounting band for ALS switches must be ordered separately.

Switch Part Number	
PNP	NPN
0944520000	0942230000

Note: Specify piston code '7' in cylinder model number when using ALS Switches.

Body Mounting Band Part Number	
Bore Ø	Part Number
1.50	0853990005
2.00	0853990005
2.50	010151006M
3.25	010151007M
4.00	010151008M
5.00	010151010M
6.00	010151011M

Minimum Net Stroke for ALS Switch

Bore Ø	Stroke
1.50	3.00
2.00	3.00
2.50	2.88
3.25	2.75
4.00	2.63
5.00	2.38
6.00	2.19

12mm Cordset for ALS Switches

12mm Cordset with Female Quick Connect

M12 Straight Connector	
Cable Length	Part Number
5 meters	9126487205
2 meters	9126487202

M12 Right Angle Connector	
Cable Length	Part Number
5 meters	9126487305
2 meters	9126487302

A female connector is available for all switches with the male 12mm quick connect option. The cordsets are available with a right angle or straight connector. Cordset part numbers are listed above.

Cordset Specifications

- Connector..... Polyvinylchloride (PVC) body material, PVC contact carrier, spacing to VDE 0110 Group C, (250VAC / 300VDC)
- Contacts Gold Plated Copper Tin (CuSn), stamped from stock.
- Coupling Method..... Threaded nut: Chrome plated brass.
- Cord Construction ... PVC non-wicking, non-hygroscopic, 250VAC / 300VDC. Cable end is stripped.
- Conductors Extra high flex stranding with PVC insulation
- Temperature..... -13°F to 158°F (-25°C to 70°C)
- Protection NEMA 1, 3, 4, 6P and IEC 1P67
- Cable Length..... 6.56 ft (2m) or 16.4 ft (5m)

Straight Connector

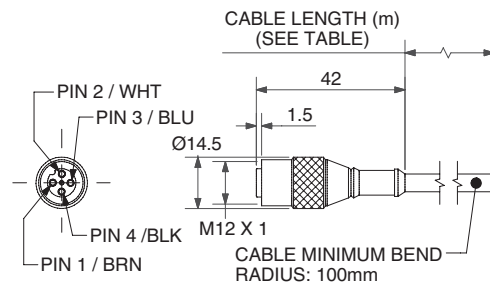

Right Angle Connector

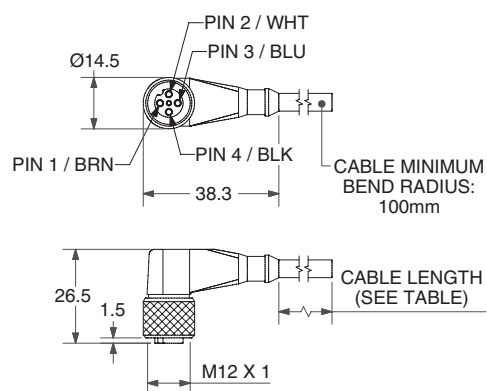

CLS-2 Threaded Style End-Of-Stroke Limit Switches

Non-contacting, magnetically-actuating

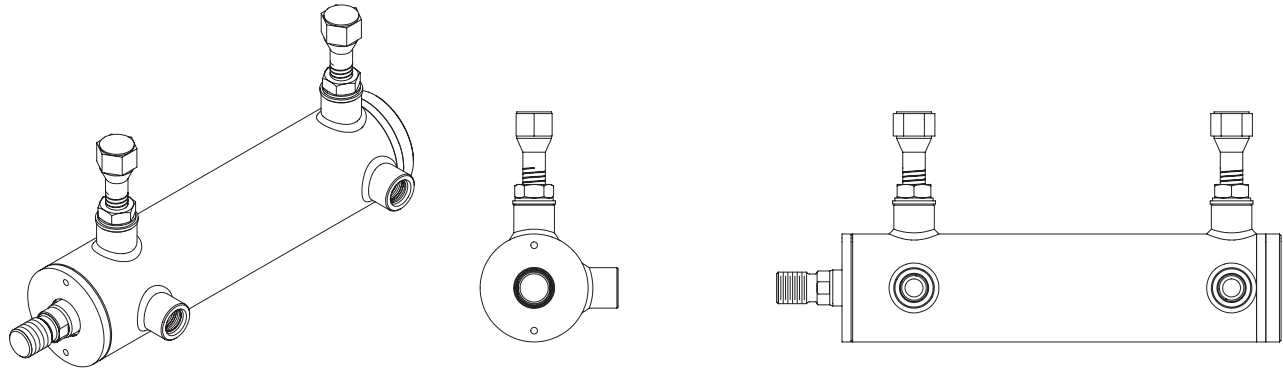

As shown in the illustrations below, these switches are magnetically operated. Dual magnets provide a dependable “snap action” for positive position sensing.

In the “Unoperated” position, the magnet assembly is attracted in the opposite direction of the arrow, causing a finely ground stainless steel connecting rod to hold the contacts open.

In the “Operated” position a ferrous part (piston or piston spacer) enters the sensing area and attracts the magnet assembly which causes the rod to draw the contacts together.

Threaded switches can be height-adjusted for small changes to end-of-stroke position sensing.

Note: Cylinders that include CLS-2 Switches may be longer than standard cylinders. Please consult the factory for exact dimensions.

Operating Principle

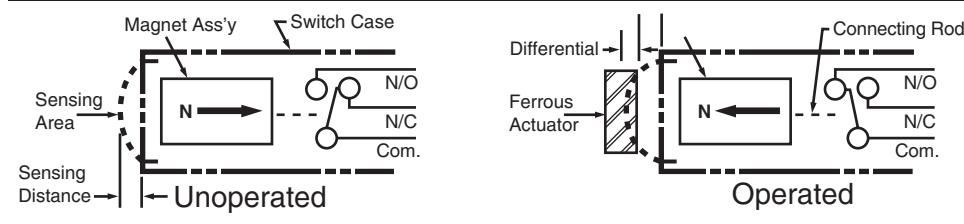

Sensing gap: .030" to .060"

Trip point: Factory set with piston bottomed out.

Release point: Approx. 0.250" of piston travel.

Minimum net stroke is 0.500" for 1.50" and 2.00" bores and 0.750" for larger bores.

Please see the specification table on the next page for additional details.

CLS-2 Limit Switch Specifications

Switch Type:	Non-contacting, magnetically actuating
Style:	CLS-2
Code Designator:	G
Description:	For applications where the customer needs NC contacts, zero leakage, zero voltage drop, higher or lower load current than EPS style. Threaded style permits small adjustability of make/break location.
Supply Voltage:	24 to 240 VAC/DC
Load Current, min.:	NA
Load Current, max.:	4 AMPS @ 120 VAC 3 AMPS @ 24 VDC
Leakage Current:	None
Voltage Drop:	None
Operating Temperature:	-40° F to +221° F
Switch Type:	Non-contacting magnetically actuated
Part Number:	117000, 117017, 117034
4 Digit Part Number Suffix:	Switch selection is application dependent – Contact Factory
Connection:	36" Potted-in PVC cable (most sizes also with 1/2" conduit hub)
Enclosure Rating:	NEMA 4, 4X, 6, 6P, 7, 9
LED Indication:	No
Short Circuit Protection:	No
Weld Field Immunity:	Yes
Output:	SPDT (Single Pole Double Throw), Normally Open/ Normally Closed, Form C
Approvals/Marks:	UL or CSA ¹
Make/Break Location:	0.13" from end of stroke, typical. Tolerance is +0/-0.13"
Wiring Instructions:	Common (Black) Normally Open (Blue) Normally Closed (Red)

¹ CSA available upon request – consult factory

CLS-2 limit switches may be ordered as follows:

- 1) Complete the basic cylinder model number.
- 2) Place an "S" in the model number for Special Modification.
- 3) Mounting styles DD, J and H should be used with caution because of possible mounting interferences.
- 4) Special modifications to cylinders other than switches must be described in the item notes.

- 5) Limit Switch Code – Specify letter prefix "G" for CLS-2, then fill in the four blanks specifying port location, switch location and actuation point for both head and cap. If only one switch is used, place "XXXX" in the unused blanks.

Example = G13GG-XXXX denotes a switch on the head end only.

Example = XXXX-G42GG denotes a switch on the cap end only.

Limit Switch Code

Head End

G	1	3	GG
Specify: "G" = CLS-2 "T" = Prepared for CLS-2 Threaded Switch "X" = Special installed switch (Specify)	Port Location See Figure 1.	Switch Location See Figure 1.	Actuation Point GG = End of Stroke.

Cap End

4	2	GG
Port Location See Figure 1.	Switch Location See Figure 1.	Actuation Point GG = End of Stroke.

Note: All specified switch and port locations are as seen from rod end of cylinder.

Figure 1

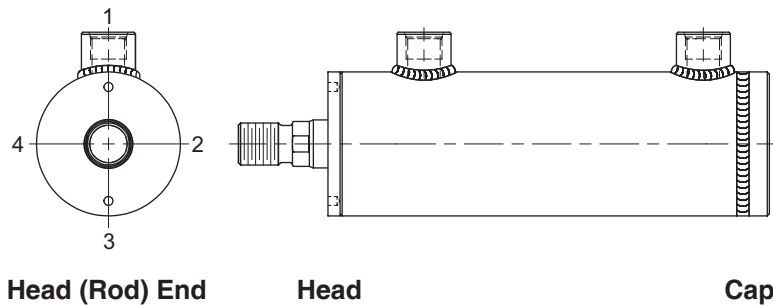

Notes

Theoretical Push Forces for Cylinders

Cylinder Bore Ø	Piston Area (In. ²)	Cylinder Push Stroke Force in Pounds at Various Pressures (psi)						
		100	250	500	1000	1500	2000	3000
1.50	1.77	177	443	885	1770	2651	3540	5310
2.00	3.14	314	785	1570	3140	4712	6280	9420
2.50	4.91	491	1228	2455	4910	7363	9820	14730
3.25	8.30	830	2075	4150	8300	12444	16600	24900
4.00	12.57	1257	3143	6285	12570	18850	25140	37710
5.00	19.64	1964	4910	9820	19640	29453	39280	58920
6.00	28.27	2827	7068	14135	28270	42412	56540	84810
7.00	38.49	3849	9623	19245	38490	57727	76980	115470
8.00	50.27	5027	12568	25135	50270	75398	100540	150810

General Formula

The cylinder output forces are derived from the formula:

$$F = P \times A$$

Where F = Force in pounds.

P = Pressure at the cylinder in pounds per square inch, gauge.

A = Effective area of cylinder piston in square inches.

Theoretical Pull Forces for Cylinders

Cylinder Bore Ø	Piston Rod Ø	Piston Rod Area (In. ²)	Cylinder Pull Force in Pounds at Various Pressures (psi)						
			100	250	500	1000	1500	2000	3000
1.50	0.625	0.307	146	365	730	1460	2190	2920	4380
	1.000	0.785	98	245	491	982	1473	1964	2946
2.00	1.000	0.785	236	589	1178	2355	3533	4710	7065
	1.375	1.48	166	414	828	1655	2483	3310	4965
2.50	1.000	0.785	413	1031	2063	4125	6188	8250	12375
	1.375	1.48	343	856	1713	3425	5138	6850	10275
	1.750	2.41	250	625	1250	2500	3750	5000	7500
3.25	1.375	1.48	682	1704	3408	6815	10223	13630	20445
	1.750	2.41	589	1473	2945	5890	8835	11780	17670
	2.000	3.14	516	1290	2580	5160	7740	10320	15480
4.00	1.750	2.41	1016	2540	5080	10160	15240	20320	30480
	2.000	3.14	943	2358	4715	9430	14145	18860	28290
	2.500	4.91	766	1915	3830	7660	11490	15320	22980
5.00	2.000	3.14	1650	4125	8250	16500	24750	33000	49500
	2.500	4.91	1473	3683	7365	14730	22095	29460	44190
	3.000	7.07	1257	3143	6285	12570	18855	25140	37710
	3.500	9.62	1002	2505	5010	10020	15030	20040	30060
6.00	2.500	4.91	2336	5840	11680	23360	35040	46720	70080
	3.000	7.07	2120	5300	10600	21200	31800	42400	63600
	3.500	9.62	1865	4663	9325	18650	27975	37300	55950
	4.000	12.57	1570	3925	7850	15700	23550	31400	47100
7.00	3.000	7.07	3142	7855	15710	31420	47130	62840	94260
	3.500	9.62	2887	7218	14435	28870	43305	57740	86610
	4.000	12.57	2592	6480	12960	25920	38880	51840	77760
	4.500	15.90	2259	5648	11295	22590	33885	45180	67770
	5.000	19.63	1886	4715	9430	18860	28290	37720	56580
8.00	3.500	9.62	4065	10163	20325	40650	60975	81300	121950
	4.000	12.57	3770	9425	18850	37700	56550	75400	113100
	4.500	15.90	3437	8593	17185	34370	51555	68740	103110
	5.000	19.63	3064	7660	15320	30640	45960	61280	91920
	5.500	23.76	2651	6628	13255	26510	39765	53020	79530



Cylinder Weights

The estimated weights shown below are for standard Series RDH hydraulic cylinders equipped with the different piston rod diameters. To determine the total net weight of a cylinder, first select the Basic Weight

for the proper mount at zero stroke, then calculate the weight of the cylinder stroke and add the result to the Basic Weight. For extra rod extension, use piston rod weight per inch shown in Table B.

Table A Cylinder Weights, in pounds, for Series RDH hydraulic cylinders

Bore Ø	Rod No.	MM Rod Ø	Single Rod Cylinders				Add Per Inch of Stroke
			Basic Weight at Zero Stroke				
			T (Basic Mount)	B, BB, SB/SBD and TT	DD	J and H	
1.50	1 (std)	0.625	2.5	3.7	5.6	3.5	0.4
	2	1.000	2.7	3.9	5.8	3.7	0.5
2.00	1 (std)	1.000	5.0	6.6	9.7	6.3	0.6
	2	1.375	5.9	7.5	10.6	7.2	0.8
2.50	1 (std)	1.000	8.8	11.3	13.7	11.6	0.8
	2	1.750	11.6	14.1	16.5	14.5	1.3
	3	1.375	10.2	12.7	15.1	13.0	1.0
3.25	1 (std)	1.375	16.5	22.5	24.9	22.7	1.4
	2	2.000	19.1	25.1	27.4	25.3	1.9
	3	1.750	17.8	23.8	26.1	24.0	1.7
4.00	1 (std)	1.750	22.3	28.3	31.4	35.2	2.1
	2	2.500	24.2	30.2	33.3	37.1	2.9
	3	2.000	23.2	29.2	32.3	36.2	2.4
5.00	1 (std)	2.000	51.2	57.2	67.7	74.9	2.7
	2	3.500	59.3	65.3	75.8	83.0	4.5
	3	2.500	55.3	61.3	71.8	78.9	3.2
6.00	1 (std)	2.500	75.7	83.7	102.8	115.1	4.3
	2	4.000	80.5	88.5	107.6	120.0	6.5
	3	3.000	78.1	86.1	105.2	117.6	4.9
7.00	1 (std)	3.000	111.8	124.8	154.0	178.5	5.3
	2	5.000	115.1	128.1	157.4	181.9	8.9
	3	4.000	113.5	126.5	155.7	180.2	6.9
8.00	1 (std)	3.500	159.6	173.6	217.4	246.7	7.5
	2	5.500	182.8	196.8	240.5	269.9	11.5
	3	4.500	171.2	185.2	229.0	258.3	9.3

Table B Extra weight for longer than standard rod extensions can be calculated from the table below.

Rod Ø	Piston Rod Weight (lbs) Per Inch	Rod Ø	Piston Rod Weight (lbs) Per Inch
0.625	0.09	3.000	2.00
1.000	0.22	3.500	2.72
1.375	0.42	4.000	3.56
1.750	0.68	4.500	4.51
2.000	0.89	5.000	5.56
2.500	1.40	5.500	6.72

Seal Information

Operating Fluids and Temperature Range

Fluidpower cylinders are designed for use with pressurized air, hydraulic oil and fire resistant fluids; in some cases special seals are required.

Standard Seals (class 1)

Class 1 seals are what is normally provided in a cylinder unless otherwise specified. They are intended for use with fluids such as: air, nitrogen, mineral base hydraulic oil or MIL-H-5606 within the temperature range of -10°F (-23°C) to +165°F (+74°C). The individual seals may be nitrile (Buna-N), enhanced polyurethane, polymyte, P.T.F.E. or filled P.T.F.E.

Water Base Fluid Seals (class 2)

Generally class 2 seals are intended for use with water base fluids within the temperature of -10°F (-23°C) to +165°F (+74°C) except for High Water Content Fluids (H.W.C.F.) in which case Class 6 seals should be used. Typical water base fluids are: Water, Water-Glycol, Water-in Emulsion, Houghto-Safe 27, 620, 5040, Mobil Pyrogard D, Shell Irus 905, Ucon Hydrolube J-4. These seals are nitrile. Rod seal and piston seal will have polymyte or P.T.F.E. back-up washer when required. Piston seal may be filled P.T.F.E. O-rings will have nitrile back-up washers when required.

Ethylene Propylene (E.P.R.) Seals (class 3)

Class 3 seals are intended for use with some Phosphate Ester Fluids between the temperatures of -10°F (-23°C) to +130°F (+54°C). Typical fluids compatible with E.P.R. seals are Skydrol 500 and 700. E.P.R. are Ethylene Propylene. Rod seal and piston seal will have a P.T.F.E. back-up washer when required. Piston seal may be filled P.T.F.E. O-rings will have EPR back-up washers when required. **Note:** E.P.R. seals are not compatible with mineral base hydraulic oil or greases. Even limited exposure to these fluids will cause severe swelling. P.T.F.E. back-up washer may not be suitable when used in a radiation environment.

Low Temperature Nitrile Seals (class 4)

Class 4 seals are intended for low temperature service with the same type of fluids as used with Class 1 seals within the temperature range of -50°F (-46°C) to +150°F (+66°C). Rod seal and piston seal will have leather, polymyte or P.T.F.E. back-up washers when required. Piston seal may be filled P.T.F.E. O-rings will have nitrile back-up washers when required. **Note:** Certain fluids may react adversely with Class 4 seals compared to Class 1 seals.

Fluorocarbon Seals (class 5)

Class 5 seals are intended for elevated temperature service or for some Phosphate Ester Fluids such as Houghto-Safe 1010, 1055, 1120; Fyrquel 150, 220, 300, 350; Mobile Pyrogard 42, 43, 53, and 55. **Note:** In addition, class 5 seals can be used with fluids listed on the next page under standard service. However, they are not compatible with Phosphate Ester Fluids such as Skydrols. Class 5 seals can operate with a temperature range of -10°F (-23°C) to +250°F (+121°C). Class 5 seals may be operated to +400°F (+204°C) with limited service life. For temperatures above +250°F (+120°C) the cylinder must be manufactured with non-studded piston rod and thread and a pinned piston to rod connection. Class 5 rod seal and piston seal will have P.T.F.E. back-up washers when required. Piston seal may be filled P.T.F.E. O-rings will have fluorocarbon back-up when required.

H.W.C.F. Seals (class 6)

Class 6 seals are intended for High Water Content Fluids (H.W.C.F.) such as Houghton, Hydrolubric 120B and Sonsel Lubrizol within the temperature range of +40°F (+4°C) to +120°F (+49°C). Class 6 seals are the same as Class 2 seals. Rod seal and piston seal will have P.T.F.E. and or polymyte back-up washers when required. Piston seal may be filled P.T.F.E. O-rings will have nitrile back-up washers when required.

Energized PTFE Seals (class 8)

Class 8 seals consist of PTFE rod seals, rod wiper seal and piston seal. All seals have o-ring energizers for sealing in static

Heavy Duty Hydraulic Roundline Cylinders Engineering Data

and dynamic applications. They are intended for high temperature applications, to 400° F (204° C), where longer seal life and improved high temperature sealing performance is required. End seal and energizer o-ring seals will be fluorocarbon. Fluid resistance is comparable to Class 5. Cylinders incorporating Class 8 Seals will not have studded piston rods.

Warning

The piston rod stud and the piston rod to piston threaded connections are secured with an anaerobic adhesive which is temperature sensitive. Cylinders are assembled with anaerobic adhesive having a maximum temperature rating of +250°F (+74°C). Cylinders specified with all other seal compounds (built before 1997) were assembled with anaerobic adhesive having a maximum operating temperature rating +165°F (+74°C). These temperature limitations are necessary to prevent the possible loosening of the threaded connections. Cylinders originally manufactured (before 1997) with class 1 seals (Nitrile) that will be exposed to ambient temperatures above +165°F (+74°C) must be modified for higher temperature service. Contact the factory immediately and arrange for the piston to rod and the stud to piston rod connections to be properly re-assembled to withstand the higher temperature service.

Hi-Load Seals

Hi-load seals consist of one PTFE dynamic piston seal with an energizer underneath. Hi-load piston arrangement includes a wear ring on the piston. The piston seal is virtually leak-free under static conditions and can tolerate high pressure. The wear ring on the piston can also tolerate high side loads. The dynamic portion of the seal is bronze filled PTFE and compatible with all conditions and fluids listed on this page. However, carbon filled PTFE will provide better seal life when used with class 6 fluids. A nitrile expander will be provided unless Class 3 or 5 seals are specified. In those cases the expander will be of E.P.R. or fluorocarbon respectively. **Note:** It may be necessary to cycle the piston seals 40 or 50 times before achieving leakage free performance.

Low Friction Hydraulic Seals

Low friction hydraulic seals are available as an option. They are sometimes used when a cylinder is controlled by a servo valve or proportional valve. The rod seals, rod wiper seal and piston seal are two-piece assemblies that include a filled PTFE dynamic seal with an o-ring energizer. The piston and head also include WearGard™ wear rings. The filled PTFE seals are compatible with the fluids listed on this page and provide virtually leak-free sealing. The energizers will be fluorocarbon unless E.P.R. seals are specified. In those cases the energizers will be E.P.R. **Note:** It may be necessary to cycle these seals 40 or 50 times before achieving leakage free performance.

Water Service

Series RDH cylinders can be modified to make them more suitable for use with water as the operating medium. The modifications include chrome-plated cylinder bore; electroless nickel-plated head, cap and piston; and a chrome plated 17-4 stainless steel piston rod.

When high water base fluids are the operating medium, hydraulic cylinders are usually supplied with high water base rod wiper and seals. Water and high water base fluid operated cylinders are best used on short stroke applications or where high pressure is applied only to clamp the load.

Warranty

Miller Fluid Power will warrant cylinders modified for water or high water content fluid service to be free of defects in materials or workmanship, but cannot accept responsibility of premature failure due to excessive wear from lack of lubricity or where failure is caused by corrosion, electrolysis or mineral deposits within the cylinder.

Fluids and Temperature Range

Class No.	Typical Fluids	Temperature Range
1 (Standard) (Nitrile, Polyurethane)	Air, Nitrogen Hydraulic Oil, Mil-H-5606 Oil	-10°F (-23°C) to +165°F (+74°C)
2 Water Base Fluid Seal	Water, Water-Glycol, Water-in-Oil Emulsion Houghto-Safe, 271, 620, 5040. Mobil Pyrogard D, Shell Iru 905. Ucon Hydrolube J-4	-10°F (-23°C) to +165°F (+74°C)
3 E.P.R.	Some Phosphate Ester Fluids Skydrol 500, 7000	-10°F (-23°C) to +130°F (+54°C)
Note: (E.P.R.) seals are not compatible with Hydraulic Oil		
4 Nitrile	Low Temperature Air or Hydraulic Oil	-50°F (-46°C) to +150°F (+66°C)
5 Fluorocarbon Seals	High Temperature Houghto-Safe 1010, 1055, 1120 Fyrquel 150, 220, 300, 550 Mobil Pyrogard 42,43,53,55	See paragraph on Fluorocarbon Seals on previous page for recommended temperature range.
Note: Fluorocarbon seals are not suitable for use with Skydrol fluid, but can be used with hydraulic oil if desired.		
6 HWCF (same seals as Class 2)	Houghton, Hydrolubric 120B Sonsol Lubrizol; for other HWCF — consult factory.	+40°F (+4°C) to +120°F (+49°C)
8 Energized PTFE	See Class 5 Seals	-15°F (-26°C) to +400°F (+204°C)

Seal Compounds by Seal Code

Seal Code	Description	Rod Wiper Seal	Rod Seal	Rod Seal Backup Ring	Piston Seal	Piston Seal Energizer	Piston Joint Seal	End Seal	End Seal Backup Ring	Wear Rings
(blank)	Standard (Class 1)	Urethane	Polyurethane	N/A	Polyurethane	Nitrile	Fluorocarbon	Nitrile	Nitrile	Composite
2	Water Base Fluid/HWCF (Classes 2 and 6)	Nitrile	Carboxilated Nitrile	PTFE	Bronze Filled PTFE	Nitrile	Fluorocarbon	Nitrile	Nitrile	Composite
X	EPR (Class 3)	EPR	EPR	PTFE	Bronze Filled PTFE	EPR	EPR	EPR	PTFE	Composite
4	Low Temperature (Class 4)	Urethane	Polyurethane	N/A	Polyurethane	Low Temperature Nitrile	Fluorocarbon	Low Temperature Nitrile	Low Temperature Nitrile	Composite
V	Fluorocarbon (Class 5)	Fluorocarbon	Fluorocarbon	PTFE	Bronze Filled PTFE	Fluorocarbon	Fluorocarbon	Fluorocarbon	Fluorocarbon	Composite
H	Extreme High Temperature (Class 8)	Bronze Filled PTFE with Fluorocarbon Energizer	Bronze Filled PTFE with Fluorocarbon Energizer	N/A	Bronze Filled PTFE	Fluorocarbon	Fluorocarbon	Fluorocarbon	Fluorocarbon	High Temperature Composite
K	Standard (with Bronze Filled PTFE Piston Seal)	Urethane	Polyurethane	N/A	Bronze Filled PTFE	Nitrile	Fluorocarbon	Nitrile	Nitrile	Composite
E	Fluorocarbon Rod Seals Only	Fluorocarbon	Fluorocarbon	PTFE	Polyurethane	Nitrile	Fluorocarbon	Nitrile	Nitrile	Composite
M	Metallic Rod Wiper, Standard Seals	Brass with Fluorocarbon Energizer	Polyurethane	N/A	Polyurethane	Nitrile	Fluorocarbon	Nitrile	Nitrile	Composite
D	Metallic Rod Wiper, Fluorocarbon Seals	Brass with Fluorocarbon Energizer	Fluorocarbon	PTFE	Bronze Filled PTFE	Fluorocarbon	Fluorocarbon	Fluorocarbon	Fluorocarbon	Composite

Ports

Ports

Series RDH cylinders can be supplied with many port styles, but SAE straight o-ring ports are standard. Extra ports are available for an additional charge.

Standard port location is position 1 as shown in the mounting drawings and Figure 1 below. Port locations other than position 1 can be specified for no additional charge if both ports are in the same new position. If either port is required to be at a different position than the other, additional charges would apply.

Figure 1

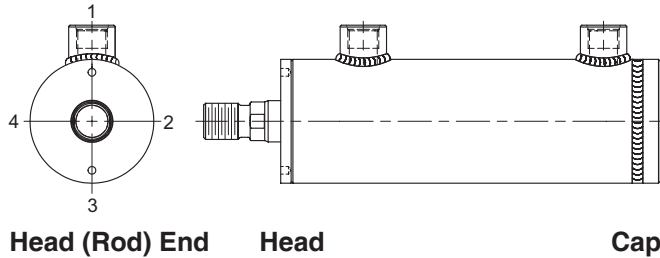

Straight Thread Ports

The SAE straight thread o-ring port is recommended for hydraulic applications. SAE port size numbers are listed next to the NPTF pipe thread counterparts for each bore size in the respective catalog pages. Size number, tube O.D., and port thread size for SAE ports are listed in Table A.

Table A

SAE Straight Thread O-Ring Ports

Size No.	Tube O.D. (in.)	Thread Size
2	0.13	5/16 - 24
3	0.19	3/8 - 24
4	0.25	7/16 - 20
5	0.31	1/2 - 20
6	0.38	9/16 - 18
8	0.50	3/4 - 16
10	0.63	7/8 - 14
12	0.75	1 1/16 - 12
16	1.00	1 5/16 - 12
20	1.25	1 5/8 - 12
24	1.50	1 7/8 - 12
32	2.00	2 1/2 - 12

Note: For the pressure ratings of individual connectors, contact your connector supplier. Hydraulic cylinders applied with meter out or deceleration circuits are subject to intensified pressure at the cylinder piston rod end. The rod end pressure is approximately equal to:

$$\frac{\text{Effective Cap End Piston Area}}{\text{Effective Rod End Piston Area}} \times \text{Operating Pressure}$$

International Ports

Other port configurations to meet international requirements are available for an additional charge. Series RDH cylinders can be supplied with British standard taper ports (BSPT). Such port has a taper of 1 in 16 measured on the diameter (1/16" per inch). The thread form is Whitworth System, and size and number of threads per inch are as follows:

Table B

British Standard Pipe Threads

Nominal Pipe Size	No. Threads Per Inch	Pipe O.D.
1/8	28	0.383
1/4	19	0.518
3/8	19	0.656
1/2	14	0.825
3/4	14	1.041
1	11	1.309
1 1/4	11	1.650
1 1/2	11	1.882
2	11	2.347

British standard parallel internal threads are designated as BSPP and have the same thread form and number of threads per inch as the BSPT type and can be supplied for an additional charge. Unless otherwise specified, the BSPP or BSPT port size supplied will be the same nominal pipe size as the NPTF port for a given bore size cylinder.

Metric ports can also be supplied to order for an additional charge. See table below for the standard port size for each bore.

Table C – Standard Port Sizes

Bore Ø	U NPTF	T SAE	R BSPP	B BSPT	G Metric
1.50	3/8	6	G3/8	Rc3/8	M18x1.5
2.00	1/2	8	G1/2	Rc1/2	M22x1.5
2.50	1/2	8	G1/2	Rc1/2	M22x1.5
3.25	3/4	12	G3/4	Rc3/4	M27x2
4.00	3/4	12	G3/4	Rc3/4	M27x2
5.00	3/4	12	G3/4	Rc3/4	M27x2
6.00	1	16	G1	Rc1	M33x2
7.00	1 1/4	20	G1-1/4	Rc1-1/4	M42x2
8.00	1 1/4	20	G1-1/4	Rc1-1/4	M42x2

Undersize and Oversize Ports

Undersize and oversize ports are available. Please consult factory.

Stroke Data

Series RDH cylinders are available in any practical stroke length.

Stroke Length Tolerance

Stroke length tolerances are required due to buildup of tolerances of the piston, head, cap and cylinder tube.

Standard stroke length tolerances are:

for strokes up to 43" = -0/+0.040"

for strokes greater than 43" = -0/+0.062"

For closer tolerances on stroke length, it is necessary to specify the required tolerance plus the pressure and temperature at which the cylinder will operate. Stroke tolerances smaller than .015" are not generally practical due to elasticity of cylinders. If machine design requires such close tolerances, use of a stroke adjuster or special endcap ties may achieve the desired result. Please consult factory.

Fatigue Life

Although each application is unique, all cylinders have a finite life. In general, welded cylinders have a limited fatigue life when used at the maximum pressure rating. Series RDH cylinders are rated for industrial-grade service but for the maximum possible fatigue life in severe duty applications, Miller Fluid Power cylinders with another construction style (tie-rod, mill-type or bolted) should be considered. If necessary, please consult the factory for assistance or review Bulletin HY08-1320-G-T1.

Note: User Responsibility. The user, through its own analysis and testing, is solely responsible for making the final selection of the system and Product and assuring that all performance, endurance, maintenance, safety and warning requirements of the application are met. The user must analyze all aspects of the application and follow applicable industry standards and Product information. If Seller provides Product or system options, the user is responsible for determining that such data and specifications are suitable and sufficient for all applications and reasonably foreseeable uses of the Products or systems.

Mounting Groups

Standard mountings for Series RDH cylinders fall into two basic groups. The groups can be summarized as follows:

Straight Line Force Transfer – fixed mounts which absorb force on the cylinder centerline

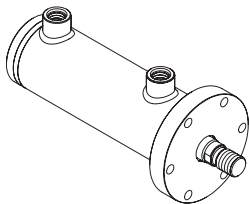

Style J

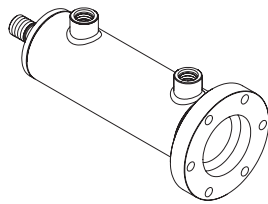

Style H

Pivot Force Transfer – mountings that permit a cylinder to change its alignment in one plane

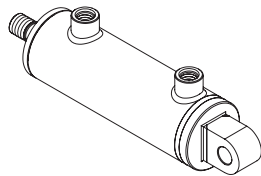

Style B

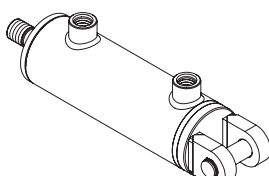

Style BB

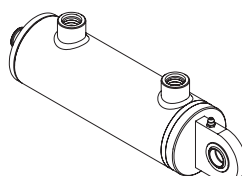

Style SB/SBM

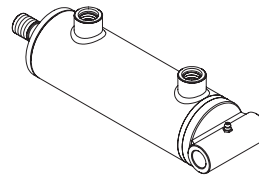

Style TT

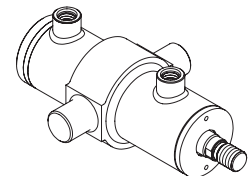

Style DD

The cylinder's mounting directly affects the maximum pressure at which the cylinder can be used. Stroke length, piston rod connection to load, extra piston rod length over standard, etc. should be considered for thrust loads. See Stop Tubing and Piston Rod Selection

Data on the following pages to first determine whether stop tubing is recommended and then determine the correct piston rod diameter for an application. Alloy steel mounting bolts are recommended for all mounting styles.

Stop Tubing

Stop tube is recommended to lengthen the distance between the rod bearing and piston bearing to reduce bearing loads on long push stroke cylinders when the cylinder is fully extended. This is especially true of horizontally mounted cylinders. As part of the piston assembly and positioned between the piston and head, a stop tube restricts the extended position of the rod using the increased distance to achieve additional stability.

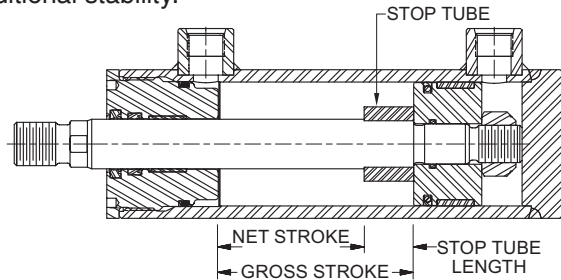

Use the following steps to determine the need for stop tube and, if required, how long it should be.

1. Examine the groups of cylinder illustrations below and determine which mounting and rod guiding group type match the required cylinder application.

2. Establish the Basic Length (L), with the piston rod fully extended, for the selected illustration by using the dimensional tables on previous pages of this catalog. For pivot mounted cylinders, the pin-to-pin dimension with the piston rod fully extended must be used. Regardless of mounting style, be sure to include any extended piston rod length beyond the catalog standard.
3. In the Stop Tube Table select the column for the appropriate mounting style and rod end guiding type. In the Basic Length (L) column, find the row with the range that includes the value calculated in Step 2. The next respective column to the right has the required length of stop tube.

Note: Mounting Styles B, BB, SB/SBM, TT and H that are mounted horizontally should also be checked for turning moments and loads between the rod bearing and piston to ensure they are not excessive. Weight of oil must be included in determining bearing loads.

When specifying cylinders with stop tube be sure to call out the net stroke and the length of the stop tube. Machine design can be continued without delay by laying in a cylinder equivalent in length to the NET STROKE PLUS STOP TUBE LENGTH, which is referred to as GROSS STROKE.

Stop Tube Table

Pivot Mounts (B, BB, SB/SBM, TT and DD)		Fixed Mounts (J and H)					
Pivoted and Rigidly Guided Rod End		Fixed and Rigidly Guided Rod End		Pivoted and Rigidly Guided Rod End		Unguided Rod End	
Basic Length (L)	Stop Tube Length	Basic Length (L)	Stop Tube Length	Basic Length (L)	Stop Tube Length	Basic Length (L)	Stop Tube Length
0 - 40	0	0 - 80	0	0 - 57	0	0 - 20	0
41 - 50	1	81 - 100	1	58 - 71	1	21 - 25	1
51 - 60	2	101 - 120	2	72 - 86	2	26 - 30	2
61 - 70	3	121 - 140	3	87 - 100	3	31 - 35	3
71 - 80	4	141 - 160	4	101 - 114	4	36 - 40	4
81 - 90	5	161 - 180	5	115 - 129	5	41 - 45	5
91 - 100	6	181 - 200	6	130 - 143	6	46 - 50	6
101 - 110	7	201 - 220	7	144 - 157	7	51 - 55	7
111 - 120	8	221 - 240	8	158 - 171	8	56 - 60	8
121 - 130	9	241 - 260	9	172 - 186	9	61 - 65	9
131 - 140	10	261 - 280	10	187 - 200	10	66 - 70	10
141 - 150	11	281 - 300	11	201 - 214	11	71 - 75	11
151 - 160	12	Consult Factory	Consult Factory	215 - 229	12	76 - 80	12
161 - 170	13			230 - 243	13	81 - 85	13
171 - 180	14			244 - 257	14	86 - 90	14
181 - 190	15			258 - 271	15	91 - 95	15
191 - 200	16			272 - 286	16	96 - 100	16
201 - 210	17			287 - 300	17	101 - 105	17
211 - 220	18			Consult Factory	Consult Factory	106 - 110	18
221 - 230	19					111 - 115	19
231 - 240	20					116 - 120	20
241 - 250	21					121 - 125	21
251 - 260	22					126 - 130	22
261 - 270	23					131 - 135	23
271 - 280	24					136 - 140	24
281 - 290	25					141 - 145	25
291 - 300	26					146 - 150	26
Consult Factory	Consult Factory					Consult Factory	Consult Factory

Cylinder Mounting and Rod Guiding Groups

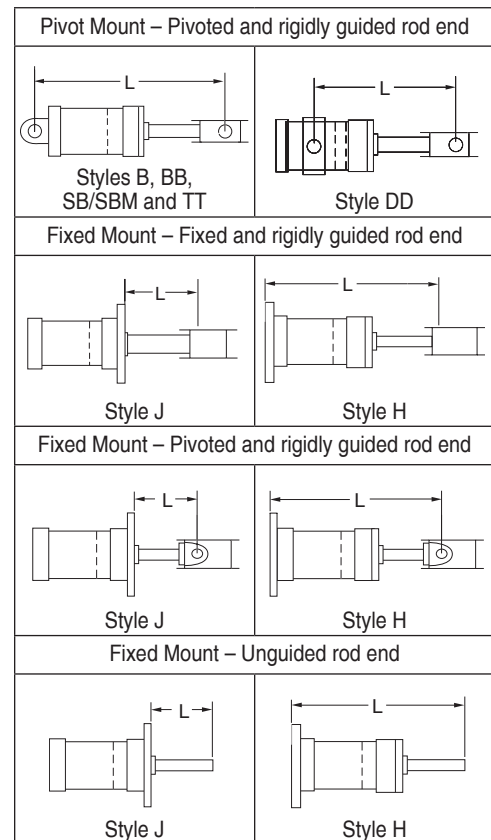

Piston Rod Diameter Selection

To determine the required rod diameter for a specific stroke, operating pressure, mounting style and rod end guiding condition, use the following steps.

1. First, determine whether stop tubing is required as described on the previous page.
2. Use the Basic Length (L) that was established for determining the stop tube length and then add the required stop tube length to the Basic Length to obtain an Adjusted Basic Length (L_A).
3. In the table below, for the mounting style and rod end guiding condition that will be used, find the row for the Bore and Rod combination that is required.

4. Follow the Bore and Rod row to the right and find the Operating Pressure column that is closest, but exceeds the system pressure. The intersection of the Bore and Rod row and Operating Pressure column displays the maximum allowable L_A.
5. If L_A in the table is less than the calculated Adjusted Basic Length move down the column to a rod diameter with an L_A that exceeds the requirement.
6. If the L_A specifies a rod diameter in a larger bore then restart the process of sizing the stop tube and re-check the rod diameter. Contact the factory if L_A exceeds 300 inches.

Note: Data in these tables assume standard rod extension (W dimension) and standard rod end accessories. If different, please consult factory.

Maximum Basic Lengths (L_A) (all dimensions in inches)

Bore Ø	Rod Ø	Rear Pivot Mounts (B, BB, SB ¹ , SBM and TT)						Front Fixed Mount (J)																	
		Pivoted and Rigidly Guided Rod End Max. Allowable Basic Length (L _A) at psi:						Fixed and Rigidly Guided Rod End Max. Allowable Basic Length (L _A) at psi:						Pivoted and Rigidly Guided Rod End Max. Allowable Basic Length (L _A) at psi:						Unguided Rod End Max. Allowable Basic Length (L _A) at psi:					
		500	1000	1500	2000	2500	3000	500	1000	1500	2000	2500	3000	500	1000	1500	2000	2500	3000	500	1000	1500	2000	2500	3000
1.50	0.625	35	25	20	18	16	14	50	35	29	25	22	20	36	25	21	18	16	15	13	9	7	6	6	5
	1.000	85	60	49	42	38	35	128	91	74	64	57	52	92	65	53	46	41	37	32	23	19	16	14	13
2.00	1.000	66	47	38	33	29	27	96	68	56	48	43	39	69	49	40	34	31	28	24	17	14	12	11	10
	1.375	116	82	67	58	52	47	182	129	105	91	81	74	130	92	75	65	58	53	45	32	26	23	20	19
2.50	1.000	54	38	31	27	24	22	77	54	44	38	34	31	55	39	32	27	25	22	19	14	11	10	9	8
	1.375	99	70	57	49	44	40	146	103	84	73	65	59	104	73	60	52	46	42	36	26	21	18	16	15
	1.750	151	106	87	75	67	61	236	167	136	118	105	96	168	119	97	84	75	69	59	42	34	29	26	24
3.25	1.375	78	55	45	39	35	32	112	79	65	56	50	46	80	57	46	40	36	33	28	20	16	14	13	11
	1.750	123	87	71	62	55	50	181	128	105	91	81	74	130	92	75	65	58	53	45	32	26	23	20	19
	2.000	157	111	90	78	70	64	237	167	137	118	106	97	169	120	98	85	76	69	59	42	34	30	26	24
4.00	1.750	102	72	59	51	45	41	147	104	85	74	66	60	105	74	61	53	47	43	37	26	21	18	16	15
	2.000	131	92	75	65	58	53	192	136	111	96	86	79	137	97	79	69	61	56	48	34	28	24	22	20
	2.500	194	137	112	97	87	79	300	213	174	150	134	123	215	152	124	107	96	88	75	53	43	38	34	31
5.00	2.000	107	76	62	53	48	44	154	109	89	77	69	63	110	78	63	55	49	45	38	27	22	19	17	16
	2.500	163	115	94	82	73	67	241	170	139	120	108	98	172	121	99	86	77	70	60	43	35	30	27	25
	3.000	226	160	130	113	101	92	300	245	200	173	155	141	247	175	143	124	111	101	87	61	50	43	39	35
	3.500	289	204	167	145	129	118	300	300	272	236	211	192	300	238	194	168	151	137	118	83	68	59	53	48
6.00	2.500	139	98	80	70	62	57	200	142	116	100	90	82	143	101	83	72	64	58	50	35	29	25	22	20
	3.000	197	139	114	98	88	80	289	204	167	144	129	118	206	146	119	103	92	84	72	51	42	36	32	29
	3.500	260	184	150	130	116	106	300	278	227	196	176	160	281	198	162	140	125	115	98	69	57	49	44	40
	4.000	300	231	188	163	146	133	300	300	296	257	229	209	300	259	212	183	164	150	128	91	74	64	57	52
7.00	3.000	171	121	99	85	76	70	247	175	143	124	111	101	177	125	102	88	79	72	62	44	36	31	28	25
	3.500	228	161	132	114	102	93	300	238	194	168	151	137	241	170	139	120	108	98	84	60	49	42	38	34
	4.000	289	204	167	145	129	118	300	300	254	220	197	180	300	222	181	157	140	128	110	78	63	55	49	45
	4.500	300	249	203	176	157	144	300	300	300	278	249	227	300	281	230	199	178	162	139	98	80	70	62	57
	5.000	300	293	239	207	185	169	300	300	300	300	300	281	300	300	283	245	220	200	172	121	99	86	77	70
8.00	3.500	203	144	117	102	91	83	295	208	170	147	132	120	210	149	122	105	94	86	74	52	43	37	33	30
	4.000	261	185	151	131	117	107	300	272	222	192	172	157	275	194	159	137	123	112	96	68	56	48	43	39
	4.500	300	229	187	162	145	132	300	300	281	244	218	199	300	246	201	174	156	142	122	86	70	61	54	50
	5.000	300	274	224	194	174	158	300	300	300	300	269	245	300	300	248	215	192	175	150	106	87	75	67	61
	5.500	300	300	261	226	202	185	300	300	300	300	300	297	300	300	300	260	232	212	182	129	105	91	81	74

¹ Maximum operating pressure is limited for the SB Mount. Please refer to maximum operating pressure per bore in SB Pressure Ratings table on page 14.

Maximum Basic Lengths (L_A) (all dimensions in inches)

Bore Ø	Rod Ø	Intermediate Pivot Mount (DD)						Rear Fixed Mount (H)																	
		Pivoted and Rigidly Guided Rod End						Fixed and Rigidly Guided Rod End						Pivoted and Rigidly Guided Rod End						Unguided Rod End					
		Max. Allowable Basic Length (L _A) at psi:						Max. Allowable Basic Length (L _A) at psi:						Max. Allowable Basic Length (L _A) at psi:						Max. Allowable Basic Length (L _A) at psi:					
		500	1000	1500	2000	2500	3000	500	1000	1500	2000	2500	3000	500	1000	1500	2000	2500	3000	500	1000	1500	2000	2500	3000
1.50	0.625	25	18	14	12	11	10	70	50	40	35	31	29	50	35	29	25	22	20	18	12	10	9	8	7
	1.000	63	44	36	31	28	25	170	120	98	85	76	69	121	86	70	61	54	50	42	30	25	21	19	17
2.00	1.000	47	33	27	23	21	19	132	93	76	66	59	54	94	67	54	47	42	38	33	23	19	16	15	13
	1.375	90	63	52	44	40	36	232	164	134	116	104	95	166	117	96	83	74	68	58	41	33	29	26	24
2.50	1.000	38	26	21	18	16	15	107	76	62	54	48	44	77	54	44	38	34	31	27	19	16	13	12	11
	1.375	72	50	41	35	32	29	197	140	114	99	88	81	141	100	81	70	63	58	49	35	28	25	22	20
	1.750	117	82	67	58	51	47	300	213	174	151	135	123	215	152	124	108	96	88	75	53	43	38	34	31
3.25	1.375	55	39	31	27	24	22	156	110	90	78	70	64	111	79	64	56	50	45	39	28	22	19	17	16
	1.750	90	63	51	44	39	36	246	174	142	123	110	100	176	124	102	88	79	72	62	44	36	31	28	25
	2.000	117	82	67	58	52	47	300	221	181	157	140	128	224	158	129	112	100	91	78	55	45	39	35	32
4.00	1.750	73	51	42	36	32	29	203	144	117	102	91	83	145	103	84	73	65	59	51	36	29	25	23	21
	2.000	95	67	54	47	42	38	261	185	151	131	117	107	187	132	108	93	83	76	65	46	38	33	29	27
	2.500	149	105	85	74	66	60	300	274	224	194	173	158	277	196	160	138	124	113	97	69	56	48	43	40
5.00	2.000	76	53	43	37	33	30	214	151	123	107	96	87	153	108	88	76	68	62	53	38	31	27	24	22
	2.500	119	84	68	59	52	48	300	231	188	163	146	133	233	165	135	117	104	95	82	58	47	41	36	33
	3.000	172	121	99	85	76	69	300	300	261	226	202	184	300	228	186	161	144	132	113	80	65	56	50	46
	3.500	234	165	135	116	104	95	300	300	300	289	259	236	300	292	239	207	185	169	145	102	83	72	65	59
6.00	2.500	99	70	57	49	44	40	278	197	161	139	124	114	199	141	115	99	89	81	70	49	40	35	31	28
	3.000	143	101	82	71	63	58	300	278	227	197	176	161	281	199	162	140	126	115	98	70	57	49	44	40
	3.500	195	138	112	97	87	79	300	300	300	260	233	212	300	263	215	186	166	152	130	92	75	65	58	53
	4.000	255	180	147	127	113	103	300	300	300	300	292	266	300	300	269	233	208	190	163	115	94	82	73	67
7.00	3.000	121	85	69	60	53	48	300	241	197	171	153	139	244	172	141	122	109	100	85	60	49	43	38	35
	3.500	166	117	95	82	73	66	300	300	263	228	204	186	300	230	188	163	146	133	114	81	66	57	51	46
	4.000	218	153	125	108	96	88	300	300	300	289	259	236	300	292	239	207	185	169	145	102	83	72	65	59
	4.500	276	195	158	137	122	111	300	300	300	300	300	288	300	300	290	252	225	205	176	124	102	88	79	72
	5.000	300	241	196	170	151	138	300	300	300	300	300	300	300	300	300	296	264	241	207	146	119	103	93	84
8.00	3.500	145	102	83	71	64	58	300	288	235	203	182	166	291	205	168	145	130	119	102	72	59	51	45	42
	4.000	190	134	109	94	84	76	300	300	300	261	234	213	300	264	216	187	167	152	131	92	75	65	58	53
	4.500	241	170	138	120	107	97	300	300	300	300	290	264	300	300	267	231	207	189	162	114	93	81	72	66
	5.000	298	210	171	148	132	120	300	300	300	300	300	300	300	300	300	277	248	226	194	137	112	97	87	79
	5.500	300	255	208	180	160	146	300	300	300	300	300	300	300	300	300	300	289	264	226	160	131	113	101	92



Safety Guide for Selecting and Using Hydraulic, Pneumatic Cylinders and Their Accessories

WARNING: ⚠ **FAILURE OF THE CYLINDER, ITS PARTS, ITS MOUNTING, ITS CONNECTIONS TO OTHER OBJECTS, OR ITS CONTROLS CAN RESULT IN:**

- Unanticipated or uncontrolled movement of the cylinder or objects connected to it.
- Falling of the cylinder or objects held up by it.
- Fluid escaping from the cylinder, potentially at high velocity.

THESE EVENTS COULD CAUSE DEATH OR PERSONAL INJURY BY, FOR EXAMPLE, PERSONS FALLING FROM HIGH LOCATIONS, BEING CRUSHED OR STRUCK BY HEAVY OR FAST MOVING OBJECTS, BEING PUSHED INTO DANGEROUS EQUIPMENT OR SITUATIONS, OR SLIPPING ON ESCAPED FLUID.

Before selecting or using Parker Hannifin Corporation (the Company) cylinders or related accessories, it is important that you read, understand and follow the following safety information. Training is advised before selecting and using the Company's products.

1.0 General Instructions

1.1 Scope – This safety guide provides instructions for selecting and using (including assembling, installing, and maintaining) cylinder products. This safety guide is a supplement to and is to be used with the specific Company publications for the specific cylinder products that are being considered for use.

1.2 Fail Safe – Cylinder products can and do fail without warning for many reasons. All systems and equipment should be designed in a fail-safe mode so that if the failure of a cylinder product occurs people and property won't be endangered.

1.3 Distribution – Provide a free copy of this safety guide to each person responsible for selecting or using cylinder products. Do not select or use the Company's cylinders without thoroughly reading and understanding this safety guide as well as the specific Company publications for the products considered or selected.

1.4 User Responsibility – Due to very wide variety of cylinder applications and cylinder operating conditions, the Company does not warrant that any particular cylinder is suitable for any specific application. This safety guide does not analyze all technical parameters that must be considered in selecting a product. The hydraulic and pneumatic cylinders outlined in this catalog are designed to the Company's design guidelines and do not necessarily meet the design guideline of other agencies such as American Bureau of Shipping, ASME Pressure Vessel Code etc. The user, through its own analysis and testing, is solely responsible for:

- Making the final selection of the cylinders and related accessories.
- Determining if the cylinders are required to meet specific design requirements as required by the Agency(s) or industry standards covering the design of the user's equipment.
- Assuring that the user's requirements are met, OSHA requirements are met, and safety guidelines from the applicable agencies such as but not limited to ANSI are followed and that the use presents no health or safety hazards.
- Providing all appropriate health and safety warnings on the equipment on which the cylinders are used.

1.5 Additional Questions – Call the appropriate Company technical service department if you have any questions or require any additional information. See the Company publication for the product being considered or used, or call 1-847-298-2400, or go to www.parker.com, for telephone numbers of the appropriate technical service department.

2.0 Cylinder and Accessories Selection

2.1 Seals – Part of the process of selecting a cylinder is the selection of seal compounds. Before making this selection, consult the "seal information page(s)" of the publication for the series of cylinders of interest.

The application of cylinders may allow fluids such as cutting fluids, wash down fluids etc. to come in contact with the external area of the cylinder. These fluids may attack the piston rod wiper and or the primary seal and must be taken into account when selecting and specifying seal compounds.

Dynamic seals will wear. The rate of wear will depend on many operating factors. Wear can be rapid if a cylinder is mis-aligned or if the cylinder has been improperly serviced. The user must take seal wear into consideration in the application of cylinders.

2.2 Piston Rods – Possible consequences of piston rod failure or separation of the piston rod from the piston include, but are not limited to are:

- Piston rod and or attached load thrown off at high speed.
- High velocity fluid discharge.
- Piston rod extending when pressure is applied in the piston retract mode.

Piston rods or machine members attached to the piston rod may move suddenly and without warning as a consequence of other conditions occurring to the machine such as, but not limited to:

- Unexpected detachment of the machine member from the piston rod.

- Failure of the pressurized fluid delivery system (hoses, fittings, valves, pumps, compressors) which maintain cylinder position.
- Catastrophic cylinder seal failure leading to sudden loss of pressurized fluid.
- Failure of the machine control system.

Follow the recommendations of the "Piston Rod Selection Chart and Data" in the publication for the series of cylinders of interest. The suggested piston rod diameter in these charts must be followed in order to avoid piston rod buckling.

Piston rods are not normally designed to absorb bending moments or loads which are perpendicular to the axis of piston rod motion. These additional loads can cause the piston rod to fail. If these types of additional loads are expected to be imposed on the piston rod, their magnitude should be made known to our engineering department.

The cylinder user should always make sure that the piston rod is securely attached to the machine member.

On occasion cylinders are ordered with double rods (a piston rod extended from both ends of the cylinder). In some cases a stop is threaded on to one of the piston rods and used as an external stroke adjuster. On occasions spacers are attached to the machine member connected to the piston rod and also used as a stroke adjuster. In both cases the stops will create a pinch point and the user should consider appropriate use of guards. If these external stops are not perpendicular to the mating contact surface, or if debris is trapped between the contact surfaces, a bending moment will be placed on the piston rod, which can lead to piston rod failure. An external stop will also negate the effect of cushioning and will subject the piston rod to impact loading. Those two (2) conditions can cause piston rod failure. Internal stroke adjusters are available with and without cushions. The use of external stroke adjusters should be reviewed with our engineering department.

The piston rod to piston and the stud to piston rod threaded connections are secured with an anaerobic adhesive. The strength of the adhesive decreases with increasing temperature. Cylinders which can be exposed to temperatures above +250°F (+121°C) are to be ordered with a non studded piston rod and a pinned piston to rod joint.

2.3 Cushions – Cushions should be considered for cylinder applications when the piston velocity is expected to be over 4 inches/second.

Cylinder cushions are normally designed to absorb the energy of a linear applied load. A rotating mass has considerably more energy than the same mass moving in a linear mode. Cushioning for a rotating mass application should be reviewed by our engineering department.

2.4 Cylinder Mountings – Some cylinder mounting configurations may have certain limitations such as but not limited to minimum stroke for side or foot mounting cylinders or pressure de-ratings for certain mounts. Carefully review the catalog for these types of restrictions.

Always mount cylinders using the largest possible high tensile alloy steel socket head cap screws that can fit in the cylinder mounting holes and torque them to the manufacturer's recommendations for their size.

2.5 Port Fittings – Hydraulic cylinders applied with meter out or deceleration circuits are subject to intensified pressure at piston rod end.

The rod end pressure is approximately equal to:

$$\frac{\text{operating pressure} \times \text{effective cap end area}}{\text{effective rod end piston area}}$$

Contact your connector supplier for the pressure rating of individual connectors.

3.0 Cylinder and Accessories Installation and Mounting

3.1 Installation

3.1.1 – Cleanliness is an important consideration, and cylinders are shipped with the ports plugged to protect them from contaminants entering the ports. These plugs should not be removed until the piping is to be installed. Before making the connection to the cylinder ports, piping should be thoroughly cleaned to remove all chips or burrs which might have resulted from threading or flaring operations.

3.1.2 – Cylinders operating in an environment where air drying materials are present such as fast-drying chemicals, paint, or weld splatter, or other hazardous conditions such as excessive heat, should have shields installed to prevent damage to the piston rod and piston rod seals.

3.1.3 – Proper alignment of the cylinder piston rod and its mating component on the machine should be checked in both the extended and retracted positions. Improper alignment will result in excessive rod gland and/or cylinder bore wear. On fixed mounting cylinders attaching the piston rod while the rod is retracted will help in achieving proper alignment.

3.1.4 – Sometimes it may be necessary to rotate the piston rod in order to thread the piston rod into the machine member. This operation must always be done with zero pressure being applied to either side of the piston. Failure to follow this procedure may result in loosening the piston to rod-threaded connection. In some rare cases the turning of the piston rod may rotate a threaded head and loosen it from the cylinder body. Confirm that this condition is not occurring. If it does, re-tighten the head firmly against the cylinder body.

For double rod cylinders it is also important that when attaching or detaching the piston rod from the machine member that the torque be applied to the piston rod end of the cylinder that is directly attaching to the machine member with the opposite end unrestrained. If the design of the machine is such that only the rod end of the cylinder opposite to where the rod attaches to the machine member can be rotated, consult the factory for further instructions.

3.2 Mounting Recommendations

3.2.1 – Always mount cylinders using the largest possible high tensile alloy steel socket head screws that can fit in the cylinder mounting holes and torque them to the manufacturer's recommendations for their size.

3.2.2 – Side-Mounted Cylinders – In addition to the mounting bolts, cylinders of this type should be equipped with thrust keys or dowel pins located so as to resist the major load.

3.2.3 – Tie Rod Mounting – Cylinders with tie rod mountings are recommended for applications where mounting space is limited. Nuts used for this mounting style should be torqued to the same value as the tie rods for that bore size.

3.2.4 – Flange Mount Cylinders – The controlled diameter of the rod gland extension on head end flange mount cylinders can be used as a pilot to locate the cylinders in relation to the machine. After alignment has been obtained, the flanges may be drilled for pins or dowels to prevent shifting.

3.2.5 – Trunnion Mountings – Cylinders require lubricated bearing blocks with minimum bearing clearances. Bearing blocks should be carefully aligned and rigidly mounted so the trunnions will not be subjected to bending moments. The rod end should also be pivoted with the pivot pin in line and parallel to axis of the trunnion pins.

3.2.6 – Clevis Mountings – Cylinders should be pivoted at both ends with centerline of pins parallel to each other. After cylinder is mounted, be sure to check to assure that the cylinder is free to swing through its working arc without interference from other machine parts.

4.0 Cylinder and Accessories Maintenance, Troubleshooting and Replacement

4.1 Storage – At times cylinders are delivered before a customer is ready to install them and must be stored for a period of time. When storage is required the following procedures are recommended.

4.1.1 – Store the cylinders in an indoor area which has a dry, clean and noncorrosive atmosphere. Take care to protect the cylinder from both internal corrosion and external damage.

4.1.2 – Whenever possible cylinders should be stored in a vertical position (piston rod up). This will minimize corrosion due to possible condensation which could occur inside the cylinder. This will also minimize seal damage.

4.1.3 – Port protector plugs should be left in the cylinder until the time of installation.

4.1.4 – If a cylinder is stored full of hydraulic fluid, expansion of the fluid due to temperature changes must be considered. Installing a check valve with free flow out of the cylinder is one method.

4.1.5 – When cylinders are mounted on equipment that is stored outside for extended periods, exposed unpainted surfaces, e.g. piston rod, must be coated with a rust-inhibiting compound to prevent corrosion.

4.2 Cylinder Trouble Shooting

4.2.1 – External Leakage

4.2.1.1 – Rod seal leakage can generally be traced to worn or damaged seals. Examine the piston rod for dents, gouges or score marks, and replace piston rod if surface is rough.

Rod seal leakage could also be traced to bearing wear. If clearance is excessive, replace rod bearing and seal. Rod seal leakage can also be traced to seal deterioration. If seals are soft or gummy or brittle, check compatibility of seal material with lubricant used if air cylinder, or operating fluid if hydraulic cylinder. Replace with seal material, which is compatible with these fluids. If the seals are hard or have lost elasticity, it is usually due to exposure to temperatures in excess of 165°F. (+74°C). Shield the cylinder from the heat source to limit temperature to 350°F. (+177°C.) and replace with fluorocarbon seals.

4.2.1.2 – Cylinder body seal leak can generally be traced to a loose head. Torque the head to manufacturer's recommendation for that bore size.

Excessive pressure can also result in cylinder body seal leak. Determine maximum pressure to rated limits. Replace seals and retorque head as in paragraph above. Excessive pressure can also result in cylinder body seal leak. Determine if the pressure rating of the cylinder has been exceeded. If so, bring the operating pressure down to the rating of the cylinder and have the head replaced.

Pinched or extruded cylinder body seal will also result in a leak. Replace cylinder body seal and retorque as in paragraph above.

Cylinder body seal leakage due to loss of radial squeeze which shows up in the form of flat spots or due to wear on the O.D. or I.D. – Either of these are symptoms of normal wear due to high cycle rate or length of service. Replace seals as per paragraph above.

4.2.2 – Internal Leakage

4.2.2.1 – Piston seal leak (by-pass) 1 to 3 cubic inches per minute leakage is considered normal for piston ring construction. Virtually no static leak with lipseal type seals on piston should be expected. Piston seal wear is a usual cause of piston seal leakage. Replace seals as required.

4.2.2.2 – With lipseal type piston seals excessive back pressure due to over-adjustment of speed control valves could be a direct cause of rapid seal wear. Contamination in a hydraulic system can result in a scored cylinder bore, resulting in rapid seal wear. In either case, replace piston seals as required.

4.2.2.3 – What appears to be piston seal leak, evidenced by the fact that the cylinder drifts, is not always traceable to the piston. To make sure, it is suggested that one side of the cylinder piston be pressurized and the fluid line at the opposite port be disconnected. Observe leakage. If none is evident, seek the cause of cylinder drift in other component parts in the circuit.

4.2.3 – Cylinder Fails to Move the Load

4.2.3.1 – Pneumatic or hydraulic pressure is too low. Check the pressure at the cylinder to make sure it is to circuit requirements.

4.2.3.2 – Piston Seal Leak – Operate the valve to cycle the cylinder and observe fluid flow at valve exhaust ports at end of cylinder stroke. Replace piston seals if flow is excessive.

4.2.3.3 – Cylinder is undersized for the load – Replace cylinder with one of a larger bore size.

4.3 Erratic or Chatter Operation

4.3.1 – Excessive friction at rod bearing or piston bearing due to load misalignment – Correct cylinder-to-load alignment.

4.3.2 – Cylinder sized too close to load requirements – Reduce load or install larger cylinder.

4.3.3 – Erratic operation could be traced to the difference between static and kinetic friction. Install speed control valves to provide a back pressure to control the stroke.

4.4 Cylinder Modifications, Repairs, or Failed Component

Cylinders as shipped from the factory are not to be disassembled and or modified. If cylinders require modifications, these modifications must be done at company locations or by the Company's certified facilities. The Industrial Cylinder Division Engineering Department must be notified in the event of a mechanical fracture or permanent deformation of any cylinder component (excluding seals). This includes a broken piston rod, head, mounting accessory or any other cylinder component. The notification should include all operation and application details. This information will be used to provide an engineered repair that will prevent recurrence of the failure.

It is allowed to disassemble cylinders for the purpose of replacing seals or seal assemblies. However, this work must be done by strictly following all the instructions provided with the seal kits.

Offer of Sale

The items described in this document and other documents and descriptions provided by Parker Hannifin Corporation, Hydraulics Group, and its authorized distributors ("Seller") are hereby offered for sale at prices to be established by Seller. This offer and its acceptance by any customer ("Buyer") shall be governed by all of the following Terms and Conditions. Buyer's order for any item described in its document, when communicated to Seller verbally, or in writing, shall constitute acceptance of this offer. All goods or work described will be referred to as "Products".

1. Terms and Conditions. Seller's willingness to offer Products, or accept an order for Products, to or from Buyer is expressly conditioned on Buyer's assent to these Terms and Conditions and to the terms and conditions found on-line at www.parker.com/saleterms/. Seller objects to any contrary or additional term or condition of Buyer's order or any other document issued by Buyer.

2. Price Adjustments; Payments. Prices stated on the reverse side or preceding pages of this document are valid for 30 days. After 30 days, Seller may change prices to reflect any increase in its costs resulting from state, federal or local legislation, price increases from its suppliers, or any change in the rate, charge, or classification of any carrier. The prices stated on the reverse or preceding pages of this document do not include any sales, use, or other taxes unless so stated specifically. Unless otherwise specified by Seller, all prices are F.O.B. Seller's facility, and payment is due 30 days from the date of invoice. After 30 days, Buyer shall pay interest on any unpaid invoices at the rate of 1.5% per month or the maximum allowable rate under applicable law.

3. Delivery Dates; Title and Risk; Shipment. All delivery dates are approximate and Seller shall not be responsible for any damages resulting from any delay. Regardless of the manner of shipment, title to any products and risk of loss or damage shall pass to Buyer upon tender to the carrier at Seller's facility (i.e., when it's on the truck, it's yours). Unless otherwise stated, Seller may exercise its judgment in choosing the carrier and means of delivery. No deferment of shipment at Buyers' request beyond the respective dates indicated will be made except on terms that will indemnify, defend and hold Seller harmless against all loss and additional expense. Buyer shall be responsible for any additional shipping charges incurred by Seller due to Buyer's changes in shipping, product specifications or in accordance with Section 13, herein.

4. Warranty. Seller warrants that the Products sold hereunder shall be free from defects in material or workmanship for a period of eighteen months from the date of delivery to Buyer. The prices charged for Seller's products are based upon the exclusive limited warranty stated above, and upon the following disclaimer: **DISCLAIMER OF WARRANTY: THIS WARRANTY COMPRISES THE SOLE AND ENTIRE WARRANTY PERTAINING TO PRODUCTS PROVIDED HEREUNDER. SELLER DISCLAIMS ALL OTHER WARRANTIES, EXPRESS AND IMPLIED, INCLUDING MERCHANTABILITY AND FITNESS FOR A PARTICULAR PURPOSE.**

5. Claims; Commencement of Actions. Buyer shall promptly inspect all Products upon delivery. No claims for shortages will be allowed unless reported to the Seller within 10 days of delivery. No other claims against Seller will be allowed unless asserted in writing within 60 days after delivery or, in the case of an alleged breach of warranty, within 30 days after the date within the warranty period on which the defect is or should have been discovered by Buyer. Any action based upon breach of this agreement or upon any other claim arising out of this sale (other than an action by Seller for any amount due to Seller from Buyer) must be commenced within thirteen months from the date of tender of delivery by Seller or, for a cause of action based upon an alleged breach of warranty, within thirteen months from the date within the warranty period on which the defect is or should have been discovered by Buyer.

6. LIMITATION OF LIABILITY. UPON NOTIFICATION, SELLER WILL, AT ITS OPTION, REPAIR OR REPLACE A DEFECTIVE PRODUCT, OR REFUND THE PURCHASE PRICE. IN NO EVENT SHALL SELLER BE LIABLE TO BUYER FOR ANY SPECIAL, INDIRECT, INCIDENTAL OR CONSEQUENTIAL DAMAGES ARISING OUT OF, OR AS THE RESULT OF, THE SALE, DELIVERY, NON-DELIVERY, SERVICING, USE OR LOSS OF USE OF THE PRODUCTS OR ANY PART THEREOF, OR FOR ANY CHARGES OR EXPENSES OF ANY NATURE INCURRED WITHOUT SELLER'S WRITTEN CONSENT, EVEN IF SELLER HAS BEEN NEGLIGENT, WHETHER IN CONTRACT, TORT OR OTHER LEGAL THEORY. IN NO EVENT SHALL SELLER'S LIABILITY UNDER ANY CLAIM MADE BY BUYER EXCEED THE PURCHASE PRICE OF THE PRODUCTS.

7. Contingencies. Seller shall not be liable for any default or delay in performance if caused by circumstances beyond the reasonable control of Seller.

8. User Responsibility. The user, through its own analysis and testing, is solely responsible for making the final selection of the system and Product and assuring that all performance, endurance, maintenance, safety and warning requirements of the application are met. The user must analyze all aspects of the application and follow applicable industry standards and Product information. If Seller provides Product or system options, the user is responsible for determining that such data and specifications are suitable and sufficient for all applications and reasonably foreseeable uses of the Products or systems.

9. Loss to Buyer's Property. Any designs, tools, patterns, materials, drawings, confidential information or equipment furnished by Buyer or any other items which become Buyer's property, may be considered obsolete and may be destroyed by Seller after two consecutive years have elapsed without Buyer placing an order for the items which are manufactured using such property. Seller shall not be responsible for any loss or damage to such property while it is in Seller's possession or control.

10. Special Tooling. A tooling charge may be imposed for any special tooling, including without limitation, dies, fixtures, molds and patterns, acquired to manufacture Products. Such special tooling shall be and remain Seller's property notwithstanding payment of any charges by Buyer. In no event will Buyer acquire any interest in apparatus belonging to Seller which is utilized in the manufacture of the Products, even if such apparatus has been specially converted or adapted for such manufacture and notwithstanding any charges paid by Buyer. Unless otherwise agreed, Seller shall have the right to alter, discard or otherwise dispose of any special tooling or other property in its sole discretion at any time.

11. Buyer's Obligation; Rights of Seller. To secure payment of all sums due or otherwise, Seller shall retain a security interest in the goods delivered and this agreement shall be deemed a Security Agreement under the Uniform Commercial Code. Buyer authorizes Seller as its attorney to execute and file on Buyer's behalf all documents Seller deems necessary to perfect its security interest. Seller shall have a security interest in, and lien upon, any property of Buyer in Seller's possession as security for the payment of any amounts owed to Seller by Buyer.

12. Improper Use and Indemnity. Buyer shall indemnify, defend, and hold Seller harmless from any claim, liability, damages, lawsuits, and costs (including attorney fees), whether for personal injury, property damage, patent, trademark or copyright infringement or any other claim, brought by or incurred by Buyer, Buyer's employees, or any other person, arising out of: (a) improper selection, improper application or other misuse of Products purchased by Buyer from Seller; (b) any act or omission, negligent or otherwise, of Buyer; (c) Seller's use of patterns, plans, drawings, or specifications furnished by Buyer to manufacture Product; or (d) Buyer's failure to comply with these terms and conditions. Seller shall not indemnify Buyer under any circumstance except as otherwise provided.

13. Cancellations and Changes. Orders shall not be subject to cancellation or change by Buyer for any reason, except with Seller's written consent and upon terms that will indemnify, defend and hold Seller harmless against all direct, incidental and consequential loss or damage. Seller may change product features, specifications, designs and availability with notice to Buyer.

14. Limitation on Assignment. Buyer may not assign its rights or obligations under this agreement without the prior written consent of Seller.

15. Entire Agreement. This agreement contains the entire agreement between the Buyer and Seller and constitutes the final, complete and exclusive expression of the terms of the agreement. All prior or contemporaneous written or oral agreements or negotiations with respect to the subject matter are herein merged.

16. Waiver and Severability. Failure to enforce any provision of this agreement will not waive that provision nor will any such failure prejudice Seller's right to enforce that provision in the future. Invalidation of any provision of this agreement by legislation or other rule of law shall not invalidate any other provision herein. The remaining provisions of this agreement will remain in full force and effect.

17. Termination. This agreement may be terminated by Seller for any reason and at any time by giving Buyer thirty (30) days written notice of termination. In addition, Seller may by written notice immediately terminate this agreement for the following: (a) Buyer commits a breach of any provision of this agreement (b) the appointment of a trustee, receiver or custodian for all or any part of Buyer's property (c) the filing of a petition for relief in bankruptcy of the other Party on its own behalf, or by a third party (d) an assignment for the benefit of creditors, or (e) the dissolution or liquidation of the Buyer.

18. Governing Law. This agreement and the sale and delivery of all Products hereunder shall be deemed to have taken place in and shall be governed and construed in accordance with the laws of the State of Ohio, as applicable to contracts executed and wholly performed therein and without regard to conflicts of laws principles. Buyer irrevocably agrees and consents to the exclusive jurisdiction and venue of the courts of Cuyahoga County, Ohio with respect to any dispute, controversy or claim arising out of or relating to this agreement. Disputes between the parties shall not be settled by arbitration unless, after a dispute has arisen, both parties expressly agree in writing to arbitrate the dispute.

19. Indemnity for Infringement of Intellectual Property Rights. Seller shall have no liability for infringement of any patents, trademarks, copyrights, trade dress, trade secrets or similar rights except as provided in this Section. Seller will defend and indemnify Buyer against allegations of infringement of U.S. patents, U.S. trademarks, copyrights, trade dress and trade secrets ("Intellectual Property Rights"). Seller will defend at its expense and will pay the cost of any settlement or damages awarded in an action brought against Buyer based on an allegation that a Product sold pursuant to this Agreement infringes the Intellectual Property Rights of a third party. Seller's obligation to defend and indemnify Buyer is contingent on Buyer notifying Seller within ten (10) days after Buyer becomes aware of such allegations of infringement, and Seller having sole control over the defense of any allegations or actions including all negotiations for settlement or compromise. If a Product is subject to a claim that it infringes the Intellectual Property Rights of a third party, Seller may, at its sole expense and option, procure for Buyer the right to continue using the Product, replace or modify the Product so as to make it noninfringing, or offer to accept return of the Product and return the purchase price less a reasonable allowance for depreciation. Notwithstanding the foregoing, Seller shall have no liability for claims of infringement based on information provided by Buyer, or directed to Products delivered hereunder for which the designs are specified in whole or part by Buyer, or infringements resulting from the modification, combination or use in a system of any Product sold hereunder. The foregoing provisions of this Section shall constitute Seller's sole and exclusive liability and Buyer's sole and exclusive remedy for infringement of Intellectual Property Rights.

20. Taxes. Unless otherwise indicated, all prices and charges are exclusive of excise, sales, use, property, occupational or like taxes which may be imposed by any taxing authority upon the manufacture, sale or delivery of Products.

21. Equal Opportunity Clause. For the performance of government contracts and where dollar value of the Products exceed \$10,000, the equal employment opportunity clauses in Executive Order 11246, VEVRAA, and 41 C.F.R. §§ 60-1.4(a), 60-741.5(a), and 60-250.4, are hereby incorporated.

Parker Hannifin Corporation
Miller Fluid Power
500 South Wolf Road
Des Plaines, IL 60016 USA
phone (847) 298-2400
fax (800) 892-1008
www.millerfluidpower.com

Parker Hannifin Corporation
Motion and Control Division
160 Chisholm Drive
Milton, ON Canada L9T 3G9
direct (905) 693-3000
fax (905) 876-1958
www.parker.com

