



aerospace
climate control
electromechanical
filtration
fluid & gas handling
hydraulics
pneumatics
process control
sealing & shielding



Pneumatic ISO Cylinders

Series P1D-B
According to ISO 15552

PDE2659TCUK September 2012



ENGINEERING YOUR SUCCESS.

Contents	page
P1D-B – ISO 15552 Cylinder Range	4 - 5
Cylinder forces, double acting variants	6
Main data: P1D-B	6
Total mass including moving parts	6
General technical data	7
Operating and environmental data	7
Material specification	7
Standard strokes	8
Cushioning characteristics	8
Guide for selecting suitable tubing	9
Valve series with respective flows in NI/minute	10
Order code standard strokes P1D-B	11 - 12
Dimensions	13
Cylinder mountings	14 - 18
Piston rod mountings	19 - 20
Accessories	21
Sensors	22 - 24
P1D-B Seal kits	25
Grease for P1D-B	25
Seal kit	25
Air quality	26



Important

Before attempting any external or internal work on the cylinder or any connected components, make sure the cylinder is vented and disconnect the air supply in order to ensure isolation of the air supply.



Note

All technical data in this catalogue are typical data only.
Air quality is essential for maximum cylinder service life (see ISO 8573).



WARNING

FAILURE OR IMPROPER SELECTION OR IMPROPER USE OF THE PRODUCTS AND/OR SYSTEMS DESCRIBED HEREIN OR RELATED ITEMS CAN CAUSE DEATH, PERSONAL INJURY AND PROPERTY DAMAGE.

This document and other information from Parker Hannifin Corporation, its subsidiaries and authorized distributors provide product and/or system options for further investigation by users having technical expertise. It is important that you analyze all aspects of your application and review the information concerning the product or system in the current product catalog. Due to the variety of operating conditions and applications for these products or systems, the user, through its own analysis and testing, is solely responsible for making the final selection of the products and systems and assuring that all performance, safety and warning requirements of the application are met. The products described herein, including without limitation, product features, specifications, designs, availability and pricing, are subject to change by Parker Hannifin Corporation and its subsidiaries at any time without notice.

SALE CONDITIONS

The items described in this document are available for sale by Parker Hannifin Corporation, its subsidiaries or its authorized distributors. Any sale contract entered into by Parker will be governed by the provisions stated in Parker's standard terms and conditions of sale (copy available upon request).

P1D-B Pneumatic ISO Cylinders

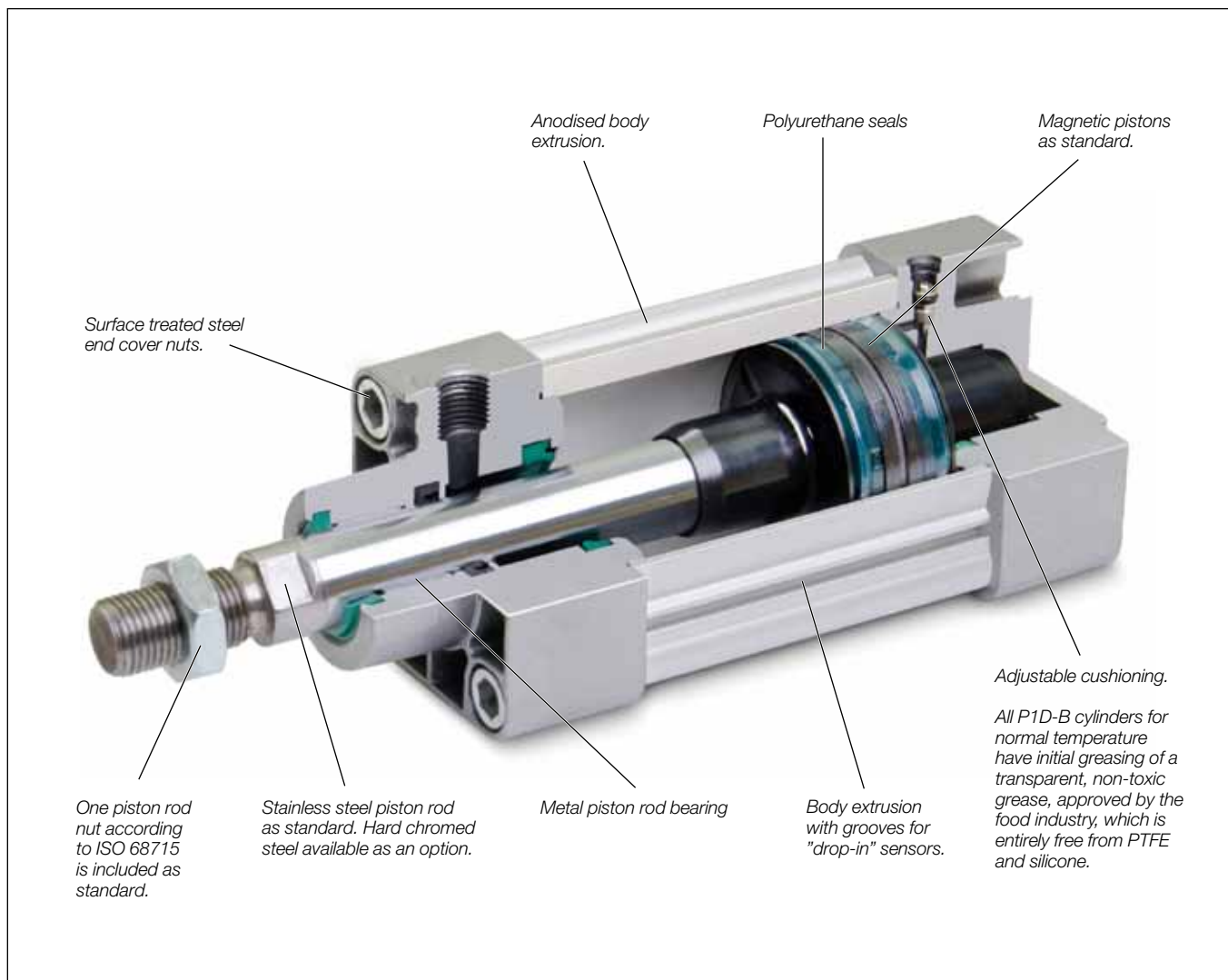

Standard cylinders P1D-B, ISO 15552

Global product range

The P1D-B Series meets the specifications in the ISO 15552 standard. This means full interchangeability to any ISO 15552 cylinder anywhere around the globe. P1D-B will be available throughout the extensive worldwide Parker Hannifin organization – for the benefit to you and your customers.

Features

- ISO 15552 conformity.
- Bore sizes 32-125 mm.
- Corrosion resistant design with barrel in anodized aluminium and stainless steel piston rod.
- Polyurethane seal technology.
- Adjustable air cushioning.
- Range of mountings available.
- Drop in global P8S-G sensors.
- Metal piston rod bearing.

P1D-B Pneumatic ISO Cylinders

Cylinder forces, double acting variants

Cyl. bore/ pist. rod mm	Stroke	Piston cm ²	Max theoretical force in N (bar)									
			1,0	2,0	3,0	4,0	5,0	6,0	7,0	8,0	9,0	10,0
32/12	+	8,0	80	161	241	322	402	483	563	643	724	804
	-	6,9	69	138	207	276	346	415	484	553	622	691
40/16	+	12,6	126	251	377	503	628	754	880	1005	1131	1257
	-	10,6	106	212	318	424	530	636	742	848	954	1060
50/20	+	19,6	196	393	589	785	982	1178	1374	1571	1767	1963
	-	16,5	165	330	495	660	825	990	1155	1319	1484	1649
63/20	+	31,2	312	623	935	1247	1559	1870	2182	2494	2806	3117
	-	28,0	280	561	841	1121	1402	1682	1962	2242	2523	2803
80/25	+	50,3	503	1005	1508	2011	2513	3016	3519	4021	4524	5027
	-	45,4	454	907	1361	1814	2268	2721	3175	3629	4082	4536
100/25	+	78,5	785	1571	2356	3142	3927	4712	5498	6283	7069	7854
	-	73,6	736	1473	2209	2945	3682	4418	5154	5890	6627	7363
125/32	+	122,7	1227	2454	3682	4909	6136	7363	8590	9817	11045	12272
	-	114,7	1147	2294	3440	4587	5734	6881	8027	9174	10321	11468

+ = Outward stroke
- = Return stroke

Note!

Select a theoretical force 50-100% larger than the force required

Main data: P1D-B

Cylinder designation	Cylinder		Piston rod		Piston rod thread	Cushioning length	Connection	
	bore	area	dia.	area			sump- tion ²⁾	thread
	mm	cm ²	mm	cm ²		mm	litre	
P1D-B032••XXXX ¹⁾	32	8,0	12	1,1	M10x1,25	17	0,105	G1/8
P1D-B040••XXXX ¹⁾	40	12,6	16	2,0	M12x1,25	19	0,162	G1/4
P1D-B050••XXXX ¹⁾	50	19,6	20	3,1	M16x1,5	20	0,253	G1/4
P1D-B063••XXXX ¹⁾	63	31,2	20	3,1	M16x1,5	23	0,414	G3/8
P1D-B080••XXXX ¹⁾	80	50,3	25	4,9	M20x1,5	23	0,669	G3/8
P1D-B100••XXXX ¹⁾	100	78,5	25	4,9	M20x1,5	27	1,043	G1/2
P1D-B125••XXXX ¹⁾	125	122,7	32	8,0	M27x2	30	1,662	G1/2

Total mass including moving parts

Cylinder designation	Total mass (kg)	
	at 0 mm stroke	Supplement per 10 mm stroke
P1D-B032••XXXX ¹⁾	0,55	0,023
P1D-B040••XXXX ¹⁾	0,80	0,033
P1D-B050••XXXX ¹⁾	1,20	0,048
P1D-B063••XXXX ¹⁾	1,73	0,051
P1D-B080••XXXX ¹⁾	2,45	0,075
P1D-B100••XXXX ¹⁾	4,00	0,084
P1D-B125••XXXX ¹⁾	6,87	0,138

Mass moving parts only (for cushioning calculation)

Cylinder designation	Mass moving parts (kg)	
	at 0 mm stroke	Supplement per 10 mm stroke
P1D-B032••XXXX ¹⁾	0,13	0,009
P1D-B040••XXXX ¹⁾	0,24	0,016
P1D-B050••XXXX ¹⁾	0,42	0,025
P1D-B063••XXXX ¹⁾	0,50	0,025
P1D-B080••XXXX ¹⁾	0,90	0,039
P1D-B100••XXXX ¹⁾	1,10	0,039
P1D-B125••XXXX ¹⁾	2,34	0,063

1) XXXX = stroke

2) Free air consumption per 10 mm stroke for a double stroke at 6 bar

P1D-B Pneumatic ISO Cylinders

General technical data

Product type	Standard cylinder according to ISO 15552	
Bore size	32 - 125 mm	
Stroke length	5-2800 mm	
Versions	P1D-B...MS	Double acting
Cushioning	Adjustable air cushioning	
Position sensing	Proximity sensor	
Installation	P1D cylinder and piston rod mountings	
Mounting position	Any	

Operating and environmental data

Operating medium	For best possible service life and trouble-free operation dry, filtered compressed air to ISO 8573-1:2010 quality class 3.4.3 should be used. This specifies a dew point of +3°C for indoor operation (a lower dew point should be selected for outdoor operation) and is in line with the air quality from most standard compressors with a standard filter.
Operating pressure	0,5 bar to 10 bar
Ambient temperature	
Standard version	-20°C to +80°C
Pre-lubricated	Further lubrication is normally not necessary. If additional lubrication is introduced it must be continued.
Corrosion resistance	Resistance to corrosion and chemicals.

Material specification

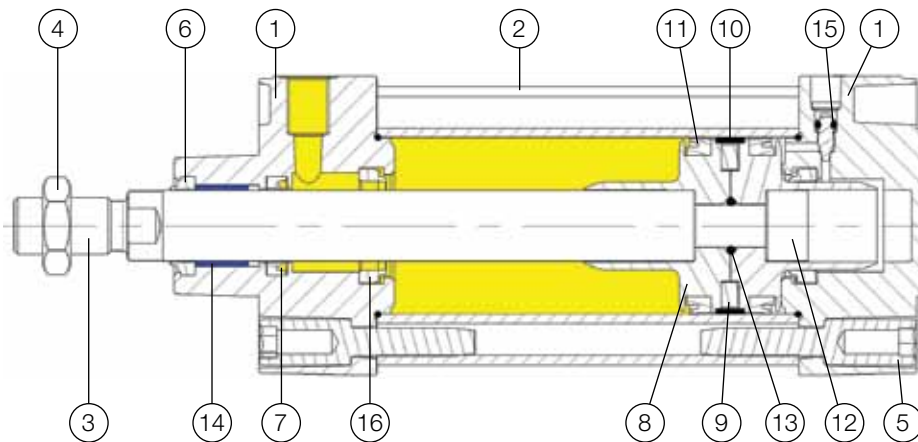

Pos	Part	Specification	
1	End covers	Aluminium	
2	Cylinder barrel	Anodised aluminium	
3	Piston rod	Standard	Stainless steel, DIN X 10 CrNiS 18 9
		Option	Hard chromium plated Fe 490-2 FN
4	Piston rod nut	Zinc plated steel	
5	End cover screws	Zinc plated steel	
6	Scraper ring	Polyurethane	
7	Piston rod seal	Polyurethane	
8	Piston	POM high tech polymer	
9	Magnet	Plastic coated magnetic material	
10	Piston bearing	POM high tech polymer	
11	Piston seals	Polyurethane	
12	Piston bolt	Zinc plated steel	
13	O-rings	Nitrile rubber	
14	Piston rod bearing	Multilayer PTFE/steel	
15	Cushioning screws	Stainless steel, DIN X 10 CrNiS 18 n9	
16	Cushioning seals		Polyurethane
		Note on materials	RoHS compliant

P1D-B Pneumatic ISO Cylinders

Cushioning characteristics

The diagram below is used for dimensioning of cylinders related to the cushioning capacity. The maximum cushioning capacity shown in the diagram assumes the following:

- Low load, i.e. low pressure drop across the piston
- Equilibrium speed
- Correctly adjusted cushioning screw
- 6 bar at cylinder port

The load is the sum of internal and external friction, plus any gravitational forces. At high relative load (pressure drop exceeding 1 bar), we recommend that for any given speed, the mass should be reduced by a factor of 2.5, or for a given mass, the speed should be reduced by a factor of 1.5. This is in relation to the maximum performance given in the diagram

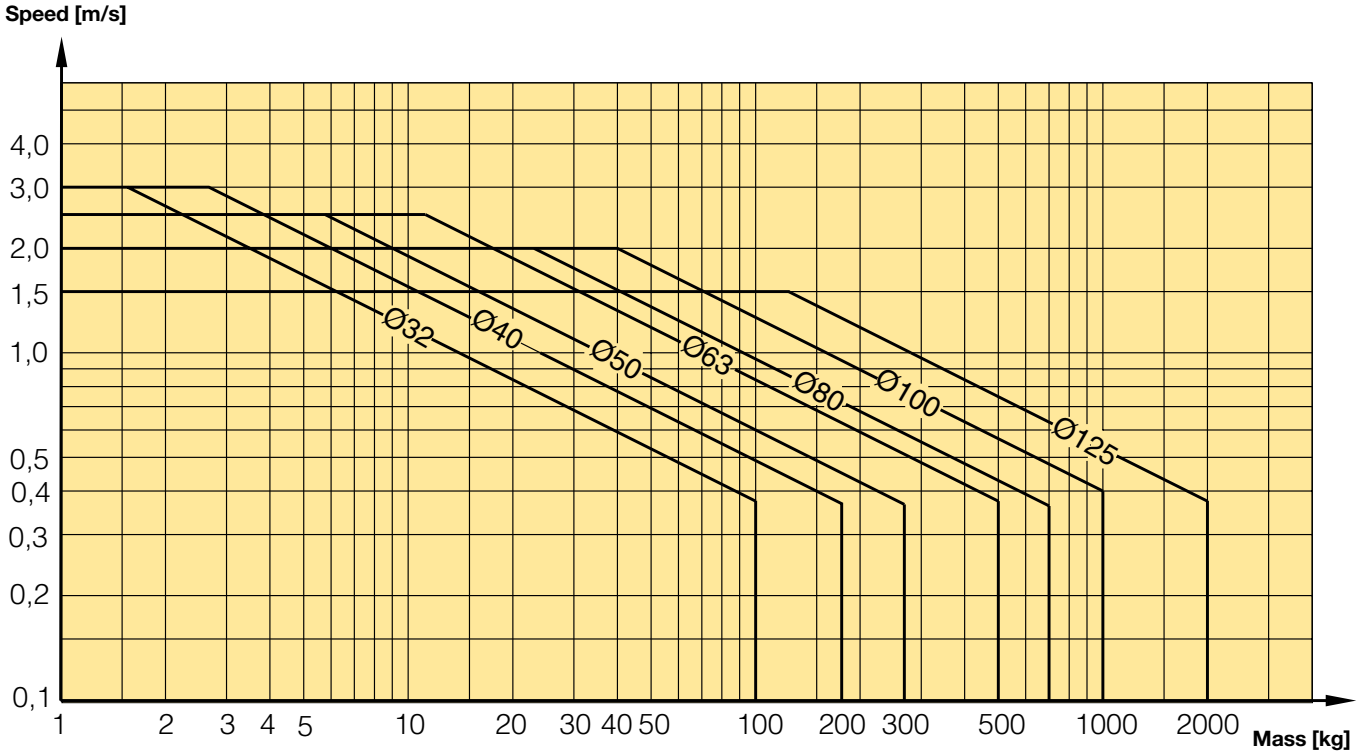

P1D-B Pneumatic ISO Cylinders

Guide for selecting suitable tubing

The selection of the correct size of tubing is often based on experience, with no great thought to optimizing energy efficiency and cylinder velocity. This is usually acceptable, but making a rough calculation can result in worthwhile economic gains.

The following is the basic principle:

1. The primary line to the working valve could be over sized (this does not cause any extra air consumption and consequently does not create any extra costs in operation).
2. The tubes between the valve and the cylinder should, however, be optimized according to the principle that an insufficient bore throttles the flow and thus limits the cylinder speed, while an oversized pipe creates a dead volume which increases the air consumption and filling time.

The chart below is intended to help when selecting the correct size of tube to use between the valve and the cylinder.

The following prerequisites apply:

The cylinder load should be about 50% of the theoretical force (= normal load). A lower load gives a higher velocity and vice versa. The tube size is selected as a function of the cylinder bore, the desired cylinder velocity and the tube length between the valve and the cylinder.

If you want to use the capacity of the valve to its maximum, and obtain maximum speed, the tubing should be chosen so that they at least correspond with the equivalent restriction diameter (see description below), so that the tubing does not restrict the total flow. This means that a short tubing must have at least the equivalent restriction diameter. If the tubing is longer, choose it from the table below. Straight fittings should be chosen for highest flow rates. (Elbow and banjo fittings cause restriction.)

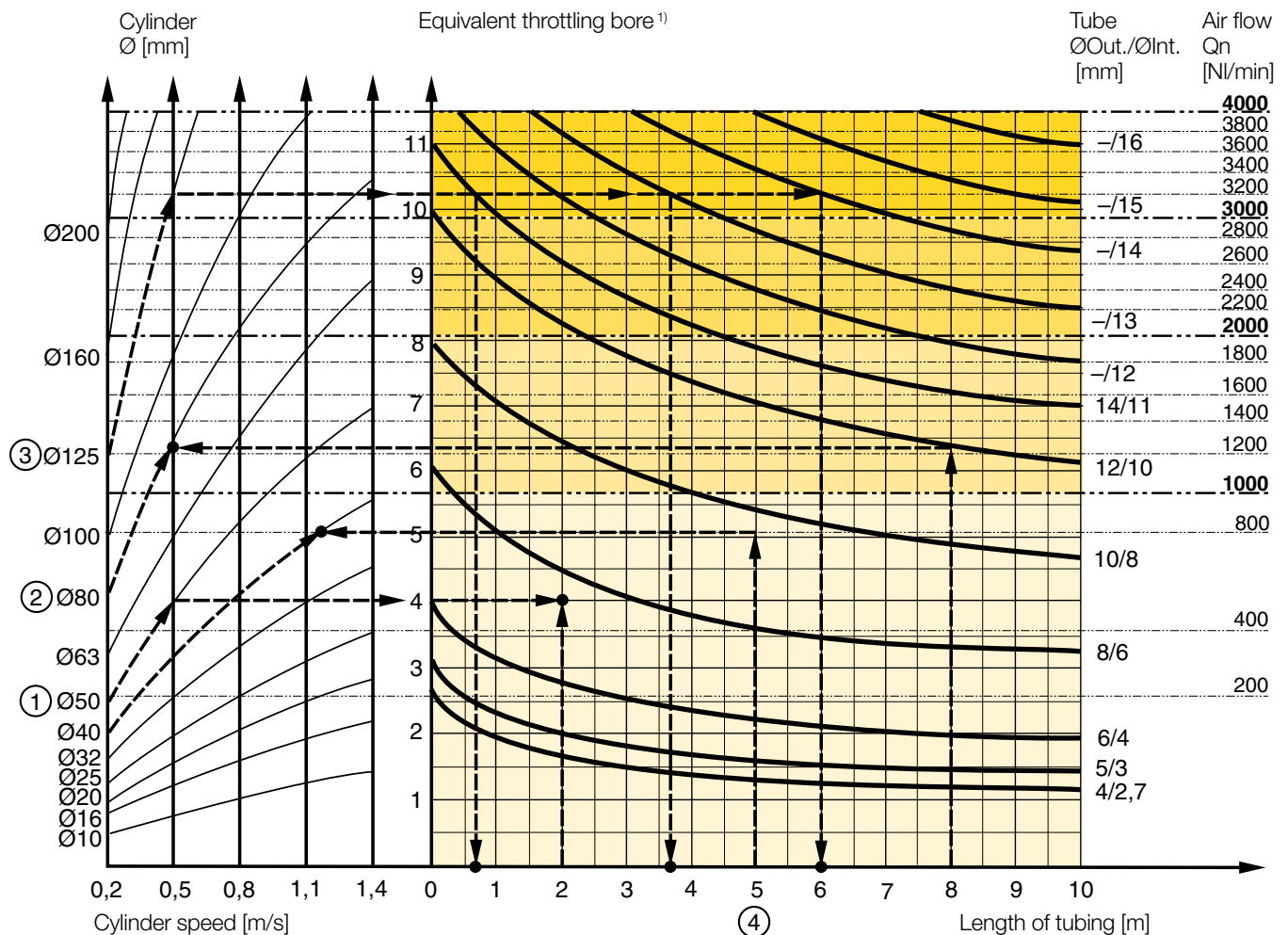

- 1) The "equivalent throttling bore" is a long throttle (for example a tube) or a series of throttles (for example, through a valve) converted to a short throttle which gives a corresponding flow rate. This should not be confused with the "orifice" which is sometimes specified for valves. The value for the orifice does not normally take account of the fact that the valve contains a number of throttles.
- 2) Qn is a measure of the valve flow capacity, with flow measured in litre per minute (l/min) at 6 bar(e) supply pressure and 1 bar pressure drop across the valve.

P1D-B Pneumatic ISO Cylinders

Example ① : Which tube diameter should be used?

A 50 mm bore cylinder is to be operated at 0.5 m/s. The tube length between the valve and cylinder is 2 m. In the diagram we follow the line from 50 mm bore to 0.5 m/s and get an “equivalent throttling bore” of approximately 4 mm. We continue out to the right in the chart and intersect the line for a 2 m tube between the curves for 4 mm (6/4 tube) and 6 mm(8/6 tube). This means that a 6/4 tube throttles the velocity somewhat, while an 8/6 tube is a little too large. We select the 8/6 tube to obtain full cylinder velocity.

Example ② : What cylinder velocity will be obtained?

A 80 mm bore cylinder will be used, connected by 8 m 12/10 tube to a valve with Qn 1200 NI/min. What cylinder velocity will we get? We refer to the diagram and follow the line from 8 mm tube length up to the curve for 12/10 tube. From there, we go horizontally to the curve for the Ø80 cylinder. We find that the velocity will be about 0.5 m/s.

Example ③ : What is the minimum inner diameter and maximum length of tube?

For an application a 125 mm bore cylinder will be used. Maximum velocity of piston rod is 0.5 m/s. The cylinder will be controlled by a valve with Qn 3200 NI/min. What diameter of tube can be used and what is maximum length of tube.

We refer to the diagram. We start at the left side of the diagram cylinder Ø125. We follow the line until the intersection with the velocity line of 0.5 m/s. From here we draw a horizontal line in the diagram. This line shows us we need an equivalent throttling bore of approximately 10 mm. Following this line horizontally we cross a few intersections. These intersections shows us the minimum inner diameter (rightside diagram) in combination with the maximum length of tube (bottomside diagram).

For example:

Intersection one: When a tube (14/11) will be used, the maximum length of tube is 0.7 meter.

Intersection two: When a tube (—/13) will be used, the maximum length of tube is 3.7 meter.

Intersection three: When a tube (—/14) will be used, the maximum length of tube is 6 meter.

Example ④ : Determining tube size and cylinder velocity with a particular cylinder and valve?

For an application using a 40 mm bore cylinder with a valve with Qn=800 NI/min. The distance between the cylinder and valve has been set to 5 m.

Tube dimension: What tube bore should be selected to obtain the maximum cylinder velocity? Start at pipe length 5 m, follow the line up to the intersection with 800 NI/min. Select the next largest tube diameter, in this case Ø10/8 mm.

Cylinder velocity: What maximum cylinder velocity will be obtained? Follow the line for 800 NI/min to the left until it intersects with the line for the Ø40 mm cylinder. In this example, the speed is just above 1.1 m/s.

Valve series with respective flows in NI/minute

Valve series	Qn in NI/Min
Interface PS1	120
Moduflex Size 1 - Double 4/2 single solenoid	165
Adex A05	173
Isys Micro - Single 5/3 APB	228
Moduflex Size 1 - Single or Double 3/2	235
Isys Micro - Double 3/2	276
Isys Micro - Single 5/2	282
Moduflex Size 1 - Single 4/2	310
ISOMAX DX02	378
ISYS ISO HB	390
Moduflex Size 2 - Single or Double 3/2	440
PVL-B stackable inline valve	540
Adex A12	560
ISOMAX DX01	588
Viking Xtrem P2LAX - G1/8"	660
Moduflex Size 2 - Single 4/2	800
ISYS ISO HA	918
ISOMAX DX1 & DX Rail	1032
PVL-C stackable inline valve	1100
ISYS ISO H1	1248
Viking Xtrem P2LBX - G1/4"	1290
ISOMAX DX2 & DX Rail	2298
Viking Xtrem P2LCX - G3/8"	2460
ISYS ISO H2	2520
Viking Xtrem P2LDX - G1/2"	2658
ISOMAX DX3 & DX Rail	3840
ISYS ISO H3	5022

Order Key Code

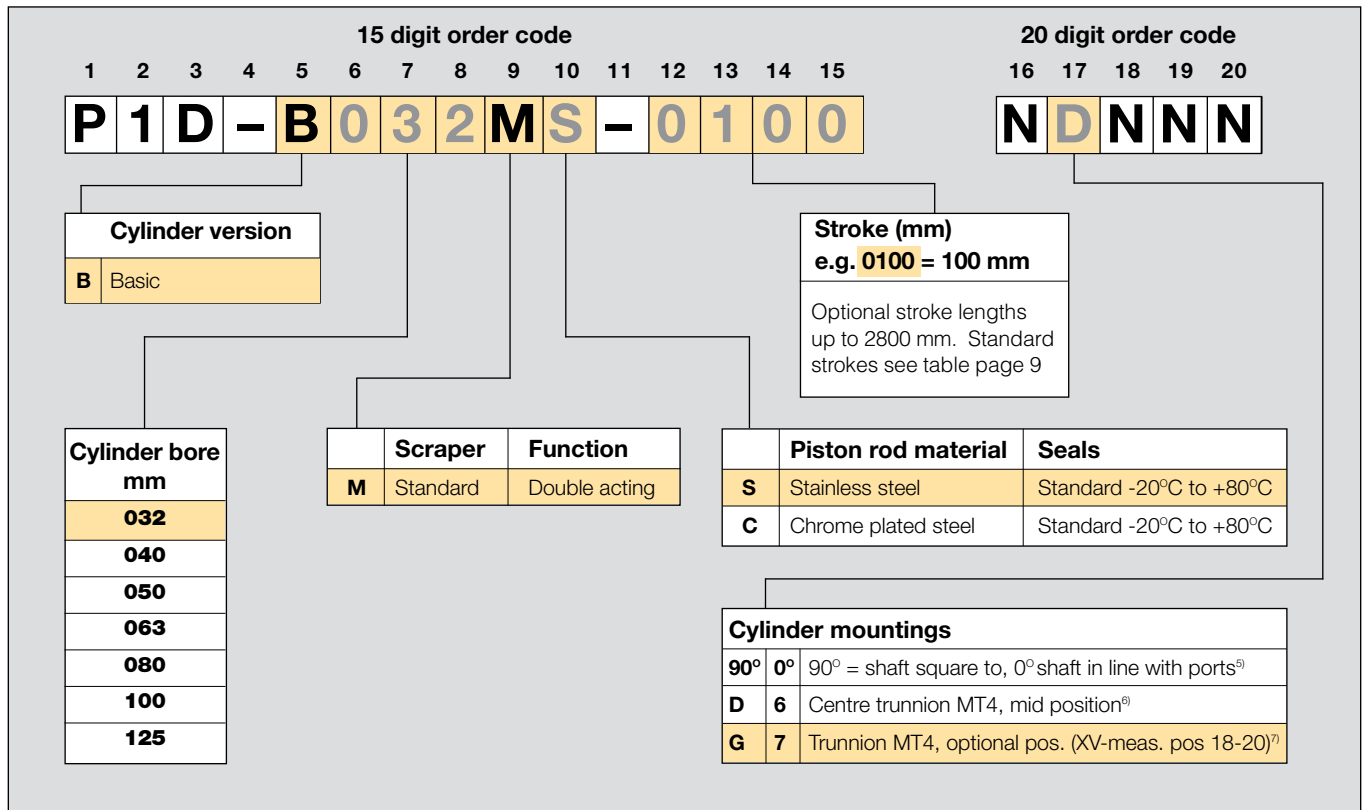

Standard strokes

Standard strokes for all P1D-B cylinders comply with ISO 4393 (with the exception of stroke 40 mm).
 Special strokes up to 2800 mm.

Order no	Cylinder bore (mm)	● = Standard stroke (mm)	■ = Stroke to special order
XXXX = Stroke		25 40 50 80 100 125 160 200 250 320 400 500 600 700 800 2800	
P1D-B			
P1D-B032MS-XXXX	32	●	■
P1D-B040MS-XXXX	40	●	■
P1D-B050MS-XXXX	50	●	■
P1D-B063MS-XXXX	63	●	■
P1D-B080MS-XXXX	80	●	■
P1D-B100MS-XXXX	100	●	■
P1D-B125MS-XXXX	125	●	■

P1D-B Pneumatic ISO Cylinders

Double acting with stainless steel piston rod

- Conforms to ISO 15552.
- Bore 32-125 mm.
- Double acting.
- Stainless steel piston rod.
- Robust design.
- Adjustable air cushioning.
- Retained stainless steel cushioning screws.
- Wide range of mountings and drop-in sensors

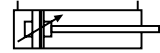

P1D-B Double-acting

Cyl. bore mm	Stroke mm	Order code
32 Conn. G1/8	25	P1D-B032MS-0025
	40	P1D-B032MS-0040
	50	P1D-B032MS-0050
	80	P1D-B032MS-0080
	100	P1D-B032MS-0100
	125	P1D-B032MS-0125
	160	P1D-B032MS-0160
	200	P1D-B032MS-0200
	250	P1D-B032MS-0250
	320	P1D-B032MS-0320
40 Conn. G1/4	25	P1D-B040MS-0025
	40	P1D-B040MS-0040
	50	P1D-B040MS-0050
	80	P1D-B040MS-0080
	100	P1D-B040MS-0100
	125	P1D-B040MS-0125
	160	P1D-B040MS-0160
	200	P1D-B040MS-0200
	250	P1D-B040MS-0250
	320	P1D-B040MS-0320
50 Conn. G1/4	25	P1D-B050MS-0025
	40	P1D-B050MS-0040
	50	P1D-B050MS-0050
	80	P1D-B050MS-0080
	100	P1D-B050MS-0100
	125	P1D-B050MS-0125
	160	P1D-B050MS-0160
	200	P1D-B050MS-0200
	250	P1D-B050MS-0250
	320	P1D-B050MS-0320
63 Conn. G3/8	25	P1D-B063MS-0025
	40	P1D-B063MS-0040
	50	P1D-B063MS-0050
	80	P1D-B063MS-0080
	100	P1D-B063MS-0100
	125	P1D-B063MS-0125
	160	P1D-B063MS-0160
	200	P1D-B063MS-0200
	250	P1D-B063MS-0250
	320	P1D-B063MS-0320

Cyl. bore mm	Stroke mm	Order code
80 Conn. G3/8	25	P1D-B080MS-0025
	40	P1D-B080MS-0040
	50	P1D-B080MS-0050
	80	P1D-B080MS-0080
	100	P1D-B080MS-0100
	125	P1D-B080MS-0125
	160	P1D-B080MS-0160
	200	P1D-B080MS-0200
	250	P1D-B080MS-0250
	320	P1D-B080MS-0320
100 Conn. G1/2	25	P1D-B100MS-0025
	40	P1D-B100MS-0040
	50	P1D-B100MS-0050
	80	P1D-B100MS-0080
	100	P1D-B100MS-0100
	125	P1D-B100MS-0125
	160	P1D-B100MS-0160
	200	P1D-B100MS-0200
	250	P1D-B100MS-0250
	320	P1D-B100MS-0320
125 Conn. G1/2	25	P1D-B125MS-0025
	40	P1D-B125MS-0040
	50	P1D-B125MS-0050
	80	P1D-B125MS-0080
	100	P1D-B125MS-0100
	125	P1D-B125MS-0125
	160	P1D-B125MS-0160
	200	P1D-B125MS-0200
	250	P1D-B125MS-0250
	320	P1D-B125MS-0320

P1D-B Pneumatic ISO Cylinders

P1D-B Basic

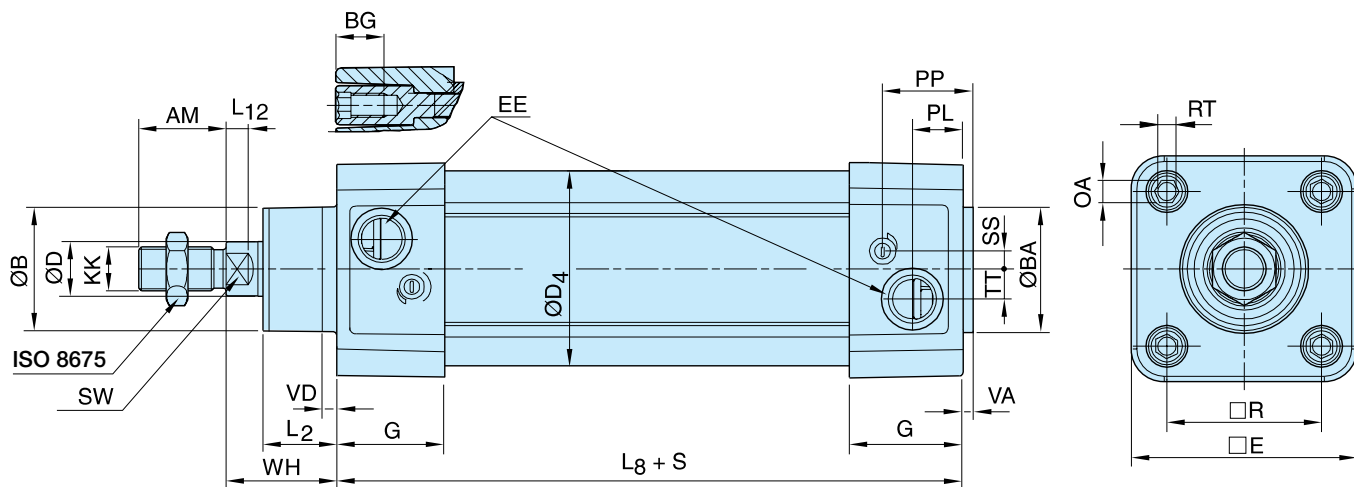

Dimensions

Cylinder bore mm	AM mm	B mm	BA mm	BG mm	D mm	D4 mm	E mm	EE mm	G mm	KK	L2 mm	L8 mm	L12 mm
32	22	30	30	16	12	45,0	48,0	G1/8	28,5	M10x1,25	16,8	94	6,0
40	24	35	35	16	16	52,0	53,5	G1/4	33,0	M12x1,25	19,0	105	6,5
50	32	40	40	16	20	60,7	65,2	G1/4	33,5	M16x1,5	24,0	106	8,0
63	32	45	45	16	20	71,5	75,5	G3/8	39,5	M16x1,5	24,3	121	8,0
80	40	45	45	17	25	86,7	95,0	G3/8	39,5	M20x1,5	30,0	128	10,0
100	40	55	55	17	25	106,7	114,0	G1/2	44,5	M20x1,5	34,0	138	14,0
125	54	60	60	20	32	134,0	139,0	G1/2	51,0	M27x2	45,0	160	18,0

Cylinder bore mm	OA mm	PL mm	PP mm	R mm	RT mm	SS mm	SW mm	TT mm	VA mm	VD mm	WH mm
32	6,0	14,0	24,2	32,5	M6	5,5	10	4,2	3,5	4,5	26
40	6,0	16,0	27,5	38,0	M6	8,0	13	5,5	3,5	4,5	30
50	8,0	14,0	29,3	46,5	M8	9,0	17	7,5	3,5	4,5	37
63	8,0	16,6	30,8	56,5	M8	6,5	17	10,0	3,5	4,5	37
80	6,0	16,8	33,5	72,0	M10	0	22	11,5	3,5	4,5	46
100	6,0	20,5	37,5	89,0	M10	0	22	14,5	3,5	4,5	51
125	8,0	23,3	45,8	110,0	M12	0	27	15,0	5,5	6,5	65

S=Stroke

Tolerances

Cylinder bore mm	B	BA	L ₈ mm	L ₉ mm	R mm	Stroke tolerance up to stroke 500 mm	Stroke tolerance for stroke over 500 mm
32	d11	d11	±0,4	±2	±0,5	+0,3/+2,0	+0,3/+3,0
40	d11	d11	±0,7	±2	±0,5	+0,3/+2,0	+0,3/+3,0
50	d11	d11	±0,7	±2	±0,6	+0,3/+2,0	+0,3/+3,0
63	d11	d11	±0,8	±2	±0,7	+0,3/+2,0	+0,3/+3,0
80	d11	d11	±0,8	±3	±0,7	+0,3/+2,0	+0,3/+3,0
100	d11	d11	±1,0	±3	±0,7	+0,3/+2,0	+0,3/+3,0
125	d11	d11	±1,0	±3	±1,1	+0,3/+2,0	+0,3/+3,0

Cylinder mountings

Flange MF1/MF2



Intended for fixed mounting of cylinder. Flange can be fitted to front or rear end cover of cylinder.

Materials
Flange: Surface-treated steel
Mounting screws acc. to DIN 6912: Zinc-plated steel 8.8

Supplied complete with mounting screws for attachment to cylinder.

According to ISO MF1/MF2, VDMA 24 562, AFNOR

Cyl. bore mm	d1 mm	FB mm	TG1 mm	E mm	R mm	MF mm	TF mm	UF mm	I1 mm	W mm	ZF mm	ZB mm
	H11	H13			JS14	JS14	JS14		-0,5			
32	30	7	32,5	45	32	10	64	80	5,0	16	130	123,5
40	35	9	38,0	52	36	10	72	90	5,0	20	145	138,5
50	40	9	46,5	65	45	12	90	110	6,5	25	155	146,5
63	45	9	56,5	75	50	12	100	120	6,5	25	170	161,5
80	45	12	72,0	95	63	16	126	150	8,0	30	190	177,5
100	55	14	89,0	115	75	16	150	170	8,0	35	205	192,5
125	60	16	110,0	140	90	20	180	205	10,5	45	245	230,5

S = Stroke length

Cyl. bore Ø mm	Weight kg	Order code
32	0,23	P1C-4KMB
40	0,28	P1C-4LMB
50	0,53	P1C-4MMB
63	0,71	P1C-4NMB
80	1,59	P1C-4PMB
100	2,19	P1C-4QMB
125	3,78	P1C-4RMB

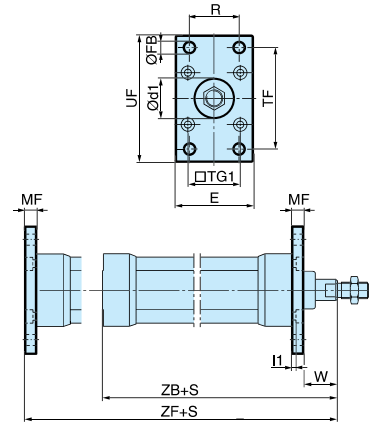

Foot bracket MS1



Intended for fixed mounting of cylinder. Foot bracket can be fitted to front and rear end covers of cylinder.

Material:
Foot bracket: Surface treated steel
Mounting screws acc. to DIN 912: Zinc-plated steel 8.8

Supplied in pairs with mounting screws for attachment to cylinder.

According to ISO MS1, VDMA 24 562, AFNOR

Cyl. bore mm	AB mm	TG1 mm	E mm	TR mm	AO mm	AU mm	AH mm	I7 mm	AT mm	I9 mm	SA mm
	H14			JS14			JS15			JS14	
32	7	32,5	47	32	8	24	32	30	4,5	17,0	142
40	9	38,0	53	36	10	28	36	30	4,5	18,5	161
50	9	46,5	65	45	10	32	45	36	5,5	25,0	170
63	9	56,5	75	50	10	32	50	35	5,5	27,5	185
80	12	72,0	95	63	14	41	63	49	6,5	40,5	210
100	14	89,0	115	75	15	41	71	54	6,5	43,5	220
125	16	110,0	140	90	20	45	90	71	8,0	60,0	250

S = Stroke length

Cyl. bore Ø mm	Weight kg	Order code
32	0,06**	P1C-4KMF
40	0,08**	P1C-4LMF
50	0,16**	P1C-4MMF
63	0,25**	P1C-4NMF
80	0,50**	P1C-4PMF
100	0,85**	P1C-4QMF
125	1,48**	P1C-4RMF

** Weight per item

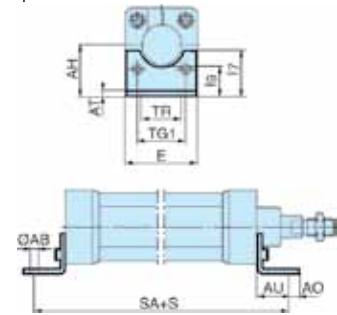

Pivot bracket with rigid bearing



Intended for flexible mounting of cylinder. The pivot bracket can be combined with clevis bracket MP2.

Material:
Pivot bracket: Aluminium
Bearing: Sintered oil-bronze bushing

According to CETOP RP 107 P, VDMA 24 562, AFNOR

Cyl. bore mm	CK mm	S5 mm	K1 mm	K2 mm	G1 mm	G2 mm	EM mm	G3 mm	CA mm	H6 mm	R1 mm
	H9	H13	JS14		JS14	JS14			JS15		
32	10	6,6	38	51	21	18	25,5	31	32	8	10,0
40	12	6,6	41	54	24	22	27,0	35	36	10	11,0
50	12	9,0	50	65	33	30	31,0	45	45	12	13,0
63	16	9,0	52	67	37	35	39,0	50	50	12	15,0
80	16	11,0	66	86	47	40	49,0	60	63	14	15,0
100	20	11,0	76	96	55	50	59,0	70	71	15	19,0
125	25	14,0	94	124	70	60	69,0	90	90	20	22,5

Cyl. bore Ø mm	Weight kg	Order code
32	0,06	P1C-4KMDB
40	0,08	P1C-4LMDB
50	0,15	P1C-4MMDB
63	0,20	P1C-4NMDB
80	0,33	P1C-4PMDB
100	0,49	P1C-4QMDB
125	1,02	P1C-4RMDB

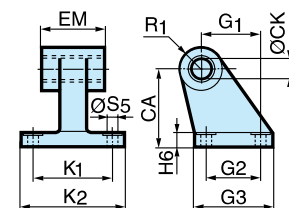

Cylinder mountings

Swivel eye bracket

Intended for use together with clevis bracket GA

Material:
Bracket: Aluminium
Swivel bearing acc. to DIN 648K: Hardened steel

Supplied complete with mounting screws for attachment to cylinder.



Cyl. bore Ø mm	Weight kg	Order code
32	0,08	PD23843
40	0,11	PD23844
50	0,20	PD23845
63	0,27	PD23846
80	0,52	PD23847
100	0,72	PD23848
125	1,53	PD23849

According to VDMA 24 562, AFNOR

Cyl. bore mm	E mm	B1 mm	B2 mm	EN mm	R1 mm	R2 mm	FL mm	I2 mm	L mm	CN H7 mm	XD mm	Z °
32	47	10,5	-	14	16	12	22	6.0	12	10	142	4°
40	55	12,0	-	16	21	14	25	6.0	15	12	160	4°
50	65	12,0	51	16	23	16	27	7.0	15	12	170	4°
63	78	15,0	-	21	27	19	32	7.0	20	16	190	4°
80	95	15,0	-	21	29	21	36	10.0	20	16	210	4°
100	115	18,0	-	25	34	24	41	10.0	25	20	230	4°
125	140	22,0	-	31	40	30	50	10.5	30	25	275	4°

S = Stroke length

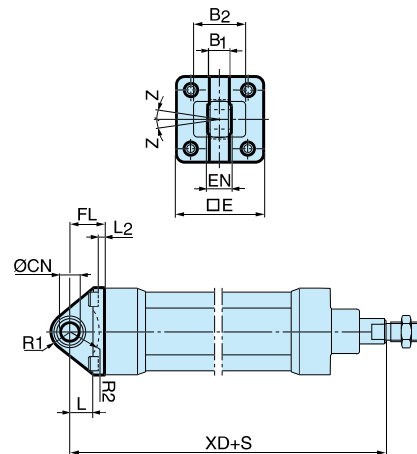

Clevis bracket MP2

Intended for flexible mounting of cylinder. Clevis bracket MP2 can be combined with clevis bracket MP4.

Material:
Clevis bracket: Aluminium
Pin: Surface hardened steel
Circlips according to DIN 471: Spring steel
Mounting screws acc. to DIN 912: Zinc-plated steel 8.8

Supplied complete with mounting screws for attachment to cylinder.



Cyl. bore Ø mm	Weight kg	Order code
32	0,08	P1C-4KMTB
40	0,11	P1C-4LMTB
50	0,14	P1C-4MMTB
63	0,29	P1C-4NMTB
80	0,36	P1C-4PMTB
100	0,64	P1C-4QMTB
125	1,17	P1C-4RMTB

According to ISO MP2, VDMA 24 562, AFNOR

Cyl. bore mm	C mm	E mm	UB h14 mm	CB H14 mm	FL ±0,2 mm	L mm	I2 mm	CD H9 mm	MR mm	XD mm
32	53	47	45	26	22	13	6,0	10	10	142
40	60	55	52	28	25	16	6,0	12	12	160
50	68	65	60	32	27	16	7,0	12	12	170
63	78	78	70	40	32	21	7,0	16	16	190
80	98	95	90	50	36	22	10,0	16	16	210
100	118	115	110	60	41	27	10,5	20	20	230
125	139	140	130	70	50	30	10,5	25	25	275

S = Stroke length

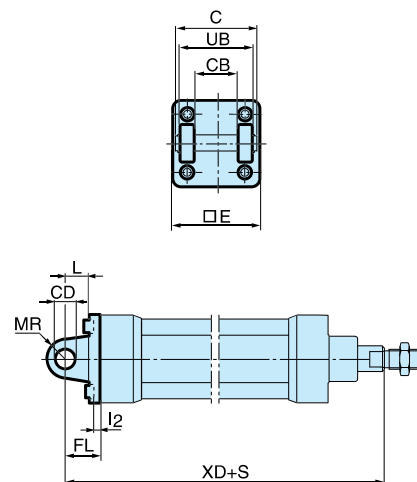

Cylinder mountings

Clevis bracket MP4



Intended for flexible mounting of cylinder. Clevis bracket MP4 can be combined with clevis bracket MP2.

Material:
 Clevis bracket: Aluminium
 Mounting screws acc. to DIN 912: Zinc-plated steel 8.8

Supplied complete with mounting screws for attachment to cylinder.

Cyl. bore Ø mm	Weight kg	Order code
32	0,09	PD23412
40	0,13	PD23413
50	0,17	PD23414
63	0,36	PD23415
80	0,46	PD23416
100	0,83	PD23417
125	1,53	PD23418

According to ISO MP4, VDMA 24 562, AFNOR

Cyl. bore mm	E mm	EW mm	FL mm	L ±0,2 mm	I2 mm	CD mm	MR H9 mm	XD mm
32	47	26	22	13	6,0	10	10	142
40	55	28	25	16	6,0	12	12	160
50	65	32	27	16	7,0	12	12	170
63	78	40	32	21	7,0	16	16	190
80	95	50	36	22	10,0	16	16	210
100	115	60	41	27	10,5	20	20	230
125	140	70	50	30	10,5	25	25	275

S = Stroke length

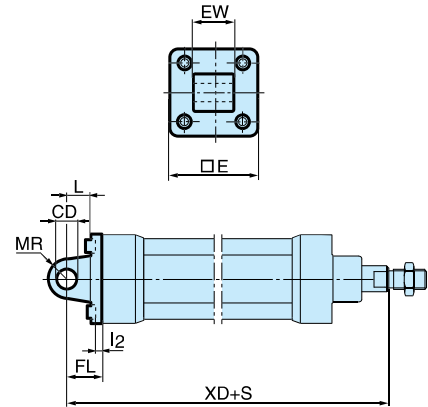

Clevis bracket GA



Intended for flexible mounting of cylinder. Clevis bracket GA can be combined with pivot bracket with swivel bearing, swivel eye bracket and swivel rod eye.

Material:
 Clevis bracket: Surface-treated aluminium
 Pin: Surface hardened steel
 Locking pin: Spring steel
 Circlips according to DIN 471: Spring steel
 Mounting screws acc. to DIN 912: Zinc-plated steel 8.8

Supplied complete with mounting screws for attachment to cylinder.

Cyl. bore Ø mm	Weight kg	Order code
32	0,09	P1C-4KMCB
40	0,13	P1C-4LMCB
50	0,17	P1C-4MMCB
63	0,36	P1C-4NMCB
80	0,58	P1C-4PMCB
100	0,89	P1C-4QMCB
125	1,75	P1C-4RMCB

According to VDMA 24 562, AFNOR

Cyl. bore mm	C mm	E mm	B2 d12 mm	B1 H14 mm	T mm	B3 mm	R2 mm	L1 mm	FL ±0,2 mm	I2 mm	L mm	CN F7 mm	R1 mm	XD mm
32	41	45	34	14	3	3,3	17	11,5	22	5,5	12	10	11	142
40	48	55	40	16	4	4,3	20	12,0	25	5,5	15	12	13	160
50	54	65	45	21	4	4,3	22	14,0	27	6,5	17	16	18	170
63	60	75	51	21	4	4,3	25	14,0	32	6,5	20	16	18	190
80	75	95	65	25	4	4,3	30	16,0	36	10,0	20	20	22	210
100	85	115	75	25	4	4,3	32	16,0	41	10,0	25	20	22	230
125	110	140	97	37	6	6,3	42	24,0	50	10,0	30	30	30	275

S = Stroke length

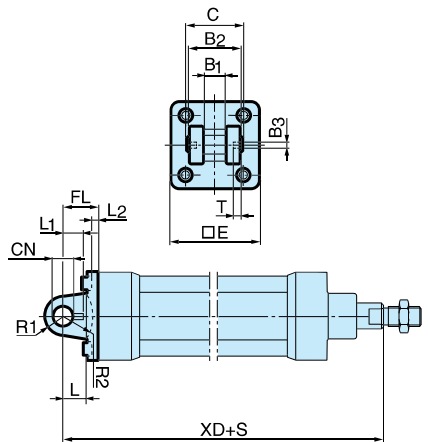

Cylinder mountings

Pivot bracket with swivel bearing

Intended for use together with clevis bracket GA.

Material:
Pivot bracket: Surface-treated steel
Swivel bearing acc. to DIN 648K: Hardened steel



According to VDMA 24 562, AFNOR

Cyl. bore mm	CN H7 mm	S5 H13 mm	K1 JS14 mm	K2 mm	EU mm	G1 JS14 mm	G2 JS14 mm	EN mm	G3 mm	CH JS15 mm	H6 mm	ER mm	Z
32	10	6,6	38	51	10,5	21	18	14	31	32	10	16	4°
40	12	6,6	41	54	12,0	24	22	16	35	36	10	18	4°
50	16	9,0	50	65	15,0	33	30	21	45	45	12	21	4°
63	16	9,0	52	67	15,0	37	35	21	50	50	12	23	4°
80	20	11,0	66	86	18,0	47	40	25	60	63	14	28	4°
100	20	11,0	76	96	18,0	55	50	25	70	71	15	30	4°
125	30	14,0	94	124	25,0	70	60	37	90	90	20	40	4°

Cyl. bore Ø mm	Weight kg	Order code
32	0,18	KC5130
40	0,25	KC5131
50	0,47	KC5132
63	0,57	KC5133
80	1,05	KC5134
100	1,42	KC5135
125	3,10	KC5136

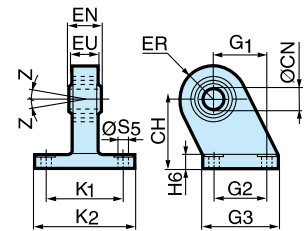

Mounting kit

Mounting kit for back to back mounted cylinders, 3 and 4 position cylinders.

Material:
Mounting: Aluminium
Mounting screws: Zinc-plated steel 8.8



Cyl. bore mm	E mm	TG mm	ØFB mm	MF mm	A mm	ØBA mm
32	50	32,5	6,5	5	16	30
40	60	38,0	6,5	5	16	35
50	66	46,5	8,5	6	20	40
63	80	56,5	8,5	6	20	45
80	100	72,0	10,5	8	25	45
100	118	89,0	10,5	8	25	55

Cyl. bore Ø mm	Weight kg	Order code
32	0,09	P1E-6KB0
40	0,13	P1E-6LB0
50	0,17	P1E-6MB0
63	0,36	P1E-6NB0
80	0,46	P1E-6PB0
100	0,83	P1E-6QB0

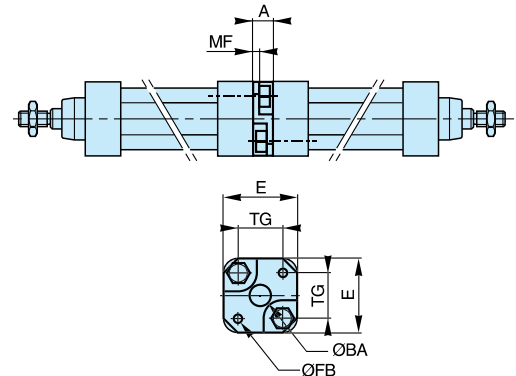

Pivot bracket for MT4

Intended for use together with centre trunnion MT4.

Material:
Pivot bracket: Aluminium
Bearing: Composite

Supplied in pairs.



According to ISO, VDMA 24 562, AFNOR

Cyl. bore mm	B1 mm	B2 mm	A mm	C mm	d1 mm	d2 H13 mm	H1 mm	H2 mm	fx45° min mm
32	55	20	36	10,5	12	8,4	26	13	1,0
40	55	20	36	12,0	16	8,4	26	13	1,6
50	55	20	36	12,0	16	8,4	26	13	1,6
63	65	25	42	13,0	20	10,5	30	15	1,6
80	65	25	42	13,0	20	10,5	30	15	1,6
100	75	28	50	16,0	25	13,0	40	20	2,0
125	75	28	50	16,0	25	13,0	40	20	2,0

Cyl. bore Ø mm	Weight kg	Order code
32	0,06	PD23381
40	0,06	PD23382
50	0,06	PD23382
63	0,10	PD23383
80	0,10	PD23383
100	0,175	PD23384
125	0,175	PD23384

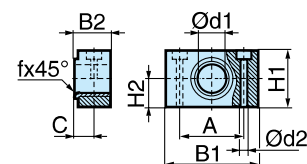

Centre trunnion MT4



Intended for articulated mounting of cylinder. The trunnion is factory-fitted in the centre of the cylinder or at an optional location specified by the XV-measure - Combined with pivot bracket for MT4.

Material:

Trunnion: Zinc plated steel

Trunnion centred

The central trunnion for the P1D-B is ordered with letter D in position 17 (no dimension specified in positions 18-20). e.g. P1D-B100MS-0500NDNNN

Trunnion with optional location

The central trunnion for the P1D-B is ordered with letter G in position 17 and desired XV-measure (3-digit measure in mm) in positions 18-20. e.g. P1D-B100MS-0500NG300
Material: nodular graphite cast iron, passivated steel

Cyl. bore Ø mm	Weight kg	Order code
32	0,13	See order key on page 9
40	0,31	
50	0,37	
63	0,69	
80	0,89	
100	1,58	
125	2,60	

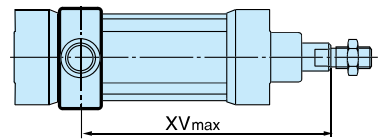
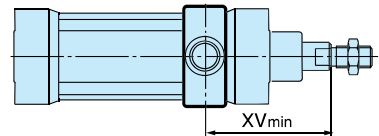
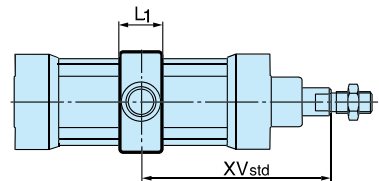
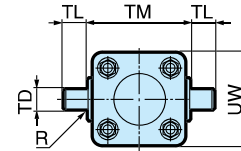

According to ISO MT4, VDMA 24 562, AFNOR

Cyl. bore mm	TM h14 mm	TL h14 mm	TD e9 mm	R mm	UW mm	L1 mm	X1* mm	XV _{min} mm	X2 mm
32	50	12	12	1,0	52	18	73,0	89	57
40	63	16	16	1,6	59	20	82,5	95	70
50	75	16	16	1,6	71	20	90,0	113	67
63	90	20	20	1,6	84	26	97,5	118	78
80	110	20	20	1,6	105	26	110,0	132	88
100	132	25	25	2,0	129	32	120,0	140	100
125	160	25	25	2,0	159	33	145,0	168	122

XVstd = X1 + Stroke length/2, XVmax = X2 + Stroke length

Cylinder mountings

Flange mounted trunnion



Intended for articulated mounting of cylinder. This trunnion can be flange mounted on the front or rear end cover of all P1D cylinders. Individual trunnions have order code as shown to the right.

Material:

Trunnion: zinc plated steel

Screws: zinc plated steel, 8.8

Delivered complete with mounting screws for attachment to the cylinder

Cyl. bore Ø mm	Weight kg	Order code
32	0,17	P1D-4KMYF
40	0,43	P1D-4LMYF
50	0,55	P1D-4MMYF
63	1,10	P1D-4NMYF
80	1,66	P1D-4PMYF
100	3,00	P1D-4QMYF

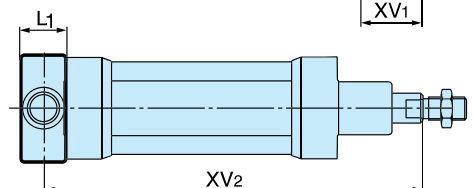
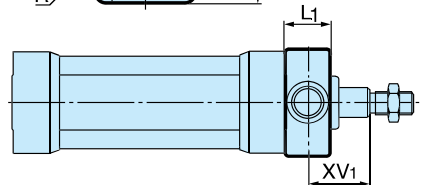
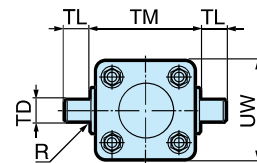

According to ISO MT4, VDMA 24 562, AFNOR

Cyl. bore mm	TM h14 mm	TL h14 mm	TD e9 mm	R mm	UW mm	L1 mm	XV ₁ mm	X mm	Y mm
32	50	12	12	1,0	46	14	19,5	126,5	11
40	63	16	16	1,6	59	19	21,0	144,0	14
50	75	16	16	1,6	69	19	28,0	152,0	20
63	90	20	20	1,6	84	24	25,5	169,5	20
80	110	20	20	1,6	102	24	34,5	185,5	26
100	132	25	25	2,0	125	29	37,0	203,0	31

Piston rod mountings

Swivel rod eye



Swivel rod eye for articulated mounting of cylinder. Swivel rod eye can be combined with clevis bracket GA. Maintenance-free.

Material:
Swivel rod eye: Zinc-plated steel
Swivel bearing according to DIN 648K: Hardened steel

Cyl. bore Ø mm	Weight kg	Order code
32	0,08	P1C-4KRS
40	0,12	P1C-4LRS
50	0,25	P1C-4MRS
63	0,25	P1C-4MRS
80	0,46	P1C-4PRS
100	0,46	P1C-4PRS
125	1,28	P1C-4RRS

According to ISO 8139

Cyl. bore mm	A mm	B min max mm	B max mm	CE mm	CN H9 mm	EN h12 mm	ER mm	KK mm	LE min mm	N mm	O mm	Z °
32	20	48,0	55	43	10	14	14	M10x1,25	15	17	10,5	12°
40	22	56,0	62	50	12	16	16	M12x1,25	17	19	12,0	12°
50	28	72,0	80	64	16	21	21	M16x1,5	22	22	15,0	15°
63	28	72,0	80	64	16	21	21	M16x1,5	22	22	15,0	15°
80	33	87,0	97	77	20	25	25	M20x1,5	26	32	18,0	15°
100	33	87,0	97	77	20	25	25	M20x1,5	26	32	18,0	15°
125	51	123,5	137	110	30	37	35	M27x2	36	41	25,0	15°

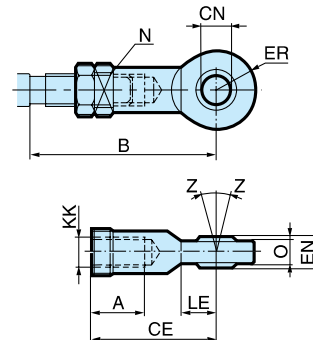

Clevis



Clevis for articulated mounting of cylinder.

Material:
Clevis, clip: Galvanized steel
Pin: Hardened steel

Cyl. bore Ø mm	Weight kg	Order code
32	0,09	P1C-4KRC
40	0,15	P1C-4LRC
50	0,35	P1C-4MRC
63	0,35	P1C-4MRC
80	0,75	P1C-4PRC
100	0,75	P1C-4PRC
125	2,10	P1C-4RRC

According to ISO 8140

Cyl. bore mm	A mm	B min max mm	B max mm	CE mm	CK h11/E9 mm	CL mm	CM mm	ER mm	KK mm	LE mm	O mm
32	20	45,0	52	40	10	20	10	16	M10x1,25	20	28,0
40	24	54,0	60	48	12	24	12	19	M12x1,25	24	32,0
50	32	72,0	80	64	16	32	16	25	M16x1,5	32	41,5
63	32	72,0	80	64	16	32	16	25	M16x1,5	32	41,5
80	40	90,0	100	80	20	40	20	32	M20x1,5	40	50,0
100	40	90,0	100	80	20	40	20	32	M20x1,5	40	50,0
125	56	123,5	137	110	30	55	30	45	M27x2	54	72,0

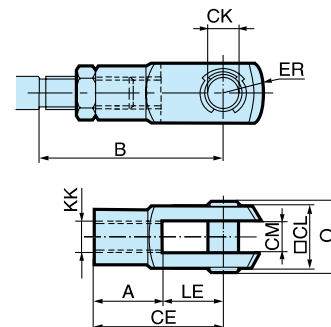

Piston rod mountings

Flexo coupling



Flexo coupling for articulated mounting of piston rod. Flexo fitting is intended to take up axial angle errors within a range of $\pm 4^\circ$.

Material
Flexo coupling, nut: Zinc-plated steel

Supplied complete with galvanized adjustment nut.

Cyl. bore Ø mm	Weight kg	Order code
32	0,23	KY1129
40	0,23	KY1131
50	0,65	KY1133
63	0,65	KY1133
80	0,71	KY1134
100	0,71	KY1134
125	1,60	KC5036

Cyl. bore mm	KK mm	B mm	C mm	D mm	E mm	OF mm	SW1 mm	SW2 mm	SW3 mm	SW4 mm	SW5 mm
32	M10x1.25	20	23	73	31	21	12	30	30	19	17
40	M12x1.25	24	23	77	31	21	12	30	30	19	19
50	M16x1.5	32	32	108	45	33,5	19	41	41	30	24
63	M16x1.5	32	32	108	45	33,5	19	41	41	30	24
80	M20x1.5	40	42	122	56	33,5	19	41	41	30	30
100	M20x1.5	40	42	122	56	33,5	19	41	41	30	30
125	M27x2	54	48	147	51	39	24	55	55	32	41

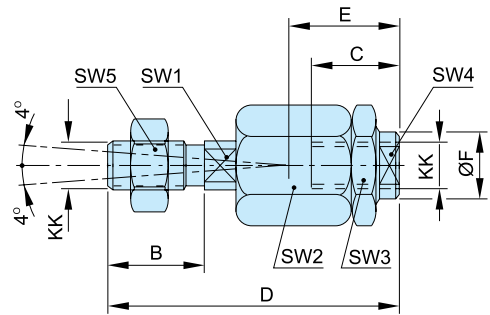

Nut



Intended for fixed mounting of accessories to the piston rod.
Material: Zinc-plated steel
Supplied as pack of 10 off

All P1D cylinders are delivered with a zinc-plated steel piston rod nut.

Cyl. bore Ø mm	Weight* kg	Order code
32	0,007	P14-4KRPZ
40	0,010	P14-4LRPZ
50	0,021	P14-4MRPZ
63	0,021	P14-4MRPZ
80	0,040	P14-4PRPZ
100	0,040	P14-4PRPZ
125	0,100	P14-4RRPZ

* Weight per item

According to DIN 439 B

Cyl. bore mm	A mm	B mm	C
32	17	5,0	M10x1,25
40	19	6,0	M12x1,25
50	24	8,0	M16x1,5
63	24	8,0	M16x1,5
80	30	10,0	M20x1,5
100	30	10,0	M20x1,5
125	41	13,5	M27x2

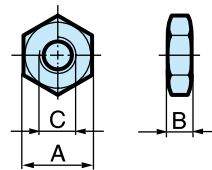

New drop-in sensors

The P1D sensors can easily be installed from the side in the sensor groove, at any position along the piston stroke. The sensors are completely recessed and thus mechanically protected. Choose between electronic or reed sensors and several cable lengths and 8 mm and M12 connectors. The same standard sensors are used for all P1D versions.



Electronic sensors

The new electronic sensors are "Solid State", i.e. they have no moving parts at all. They are provided with short-circuit protection and transient protection as standard. The built-in electronics make the sensors suitable for applications with high on and off switching frequency, and where very long service life is required.

Technical data

Design	GMR (Giant Magnetic Resistance) magneto-resistive function
Installation	From side, down into the sensor groove, so-called drop-in
Outputs	PNP, normally open (also available in NPN design, normally closed, on request)
Voltage range	10-30 VDC 10-18 V DC, ATEX sensor
Ripple	max 10%
Voltage drop	max 2,5 V
Load current	max 100 mA
Internal consumption	max 10 mA
Actuating distance	min 9 mm
Hysteresis	max 1,5 mm
Repeatability accuracy	max 0,2 mm
On/off switching frequency	max 5 kHz
On switching time	max 2 ms
Off switching time	max 2 ms
Encapsulation	IP 67 (EN 60529)
Temperature range	-25 °C to +75 °C -20 °C to +45 °C, ATEX sensor
Indication	LED, yellow
Material housing	PA 12
Material screw	Stainless steel
Cable	PVC or PUR 3x0.25 mm ² see order code respectively

Reed sensors

The sensors are based on proven reed switches, which offer reliable function in many applications. Simple installation, a protected position on the cylinder and clear LED indication are important advantages of this range of sensors.

Technical data

Design	Reed element
Mounting	From side, down into the sensor groove, so-called drop-in
Output	Normally open , or normally closed
Voltage range	10-30 V AC/DC or 10-120 V AC/DC 24-230 V AC/DC
Load current	max 500 mA for 10-30 V or max 100 mA for 10-120 V max 30 mA for 24-230 V
Breaking power (resistive)	max 6 W/VA
Actuating distance	min 9 mm
Hysteresis	max 1,5 mm
Repeatability accuracy	0,2 mm
On/off switching frequency	max 400 Hz
On switching time	max 1,5 ms
Off switching time	max 0,5 ms
Encapsulation	IP 67 (EN 60529)
Temperature range	-25 °C to +75 °C
Indication	LED, yellow
Material housing	PA12
Material screw	Stainless steel
Cable	PVC or PUR 3x0.14 mm ² see order code respectively

Electronic sensors

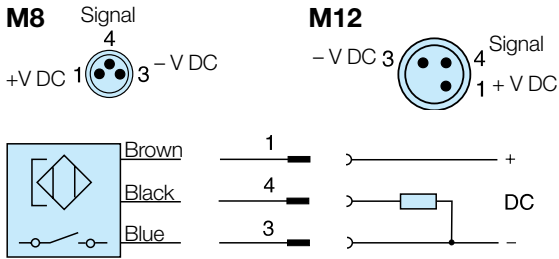

Reed sensors

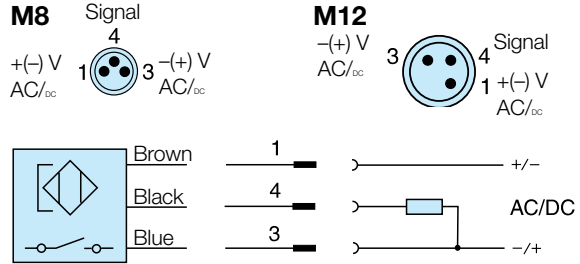

P8S-GCFPX

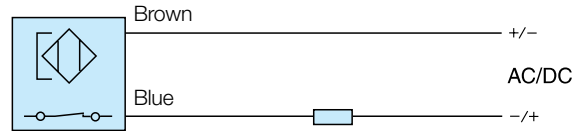

P8S-GRFLX / P8S-GRFLX2

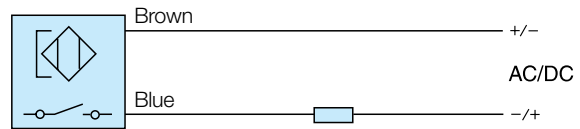

Dimensions

Sensors

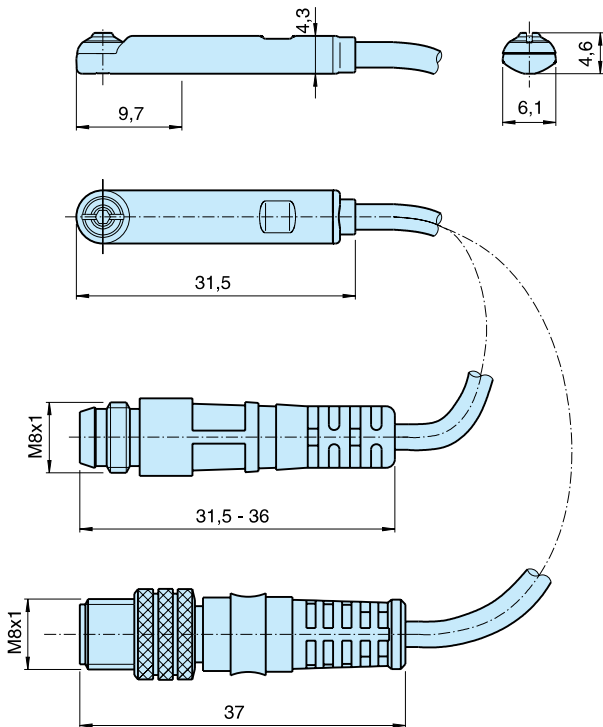

Sensor Installation

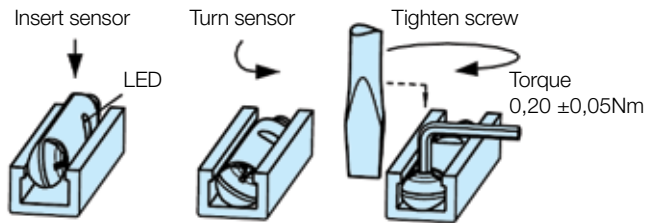

Ordering data

Output/function	Cable/connector	Weight kg	Order code
Electronic sensors , 10-30 V DC			
PNP type, normally open	0,27 m PUR-cable and 8 mm snap-in male connector	0,007	P8S-GPSHX
PNP type, normally open	0,27 m PUR-cable and M12 screw male connector	0,015	P8S-GPMHX
PNP type, normally open	3 m PVC-cable without connector	0,030	P8S-GPFLX
PNP type, normally open	10 m PVC-cable without connector	0,110	P8S-GPFTX
Reed sensors , 10-30 V AC/DC			
Normally open	0,27 m PUR-cable and 8 mm snap-in male connector	0,007	P8S-GSSHX
Normally open	0,27 m PUR-cable and M12 screw male connector	0,015	P8S-GSMHX
Normally open	3 m PVC-cable without connector	0,030	P8S-GSFLX
Normally open	10 m PVC-cable without connector	0,110	P8S-GSFTX
Normally closed	5m PVC-cable without connector ⁽¹⁾	0,050	P8S-GCFPX
Reed sensors, 10-120 V AC/DC			
Normally open	3 m PVC-cable without connector	0,030	P8S-GRFLX
Reed sensorer, 24-230 V AC/DC			
Normally open	3 m PVC-cable without connector	0,030	P8S-GRFLX2

1) Without LED

Connecting cables with one connector

The cables have an integral snap-in female connector.



Type of cable	Cable/connector	Weight	Order code kg
Cables for sensors, complete with one female connector			
Cable, Flex PVC	3 m, 8 mm Snap-in connector	0,07	9126344341
Cable, Flex PVC	10 m, 8 mm Snap-in connector	0,21	9126344342
Cable, Polyurethane	3 m, 8 mm Snap-in connector	0,01	9126344345
Cable, Polyurethane	10 m, 8 mm Snap-in connector	0,20	9126344346
Cable, Polyurethane	5 m, M12 screw connector	0,07	9126344348
Cable, Polyurethane	10 m, M12 screw connector	0,20	9126344349

Male connectors for connecting cables

Cable connectors for producing your own connecting cables. The connectors can be quickly attached to the cable without special tools. Only the outer sheath of the cable is removed. The connectors are available for M8 and M12 screw connectors and meet protection class IP 65.



Connector	Weight kg	Order code
M8 screw connector	0,017	P8CS0803J
M12 screw connector	0,022	P8CS1204J

P1D-B Seal kits

Complete seal kits consisting of:

- Piston seals
- Cushioning seals
- Piston rod seal
- O-rings
- Scraper ring

Material specification, see page 5



Order codes

Cyl.bore mm	P1D cylinder version
	Standard P1D-B
32	P1D-6KRNB
40	P1D-6LRNB
50	P1D-6MRNB
63	P1D-6NRNB
80	P1D-6PRNB
100	P1D-6QRNB
125	P1D-6RRNB

Order codes

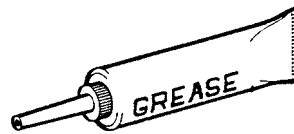

Standard	30g	9127394541
----------	-----	-------------------

Seal kit

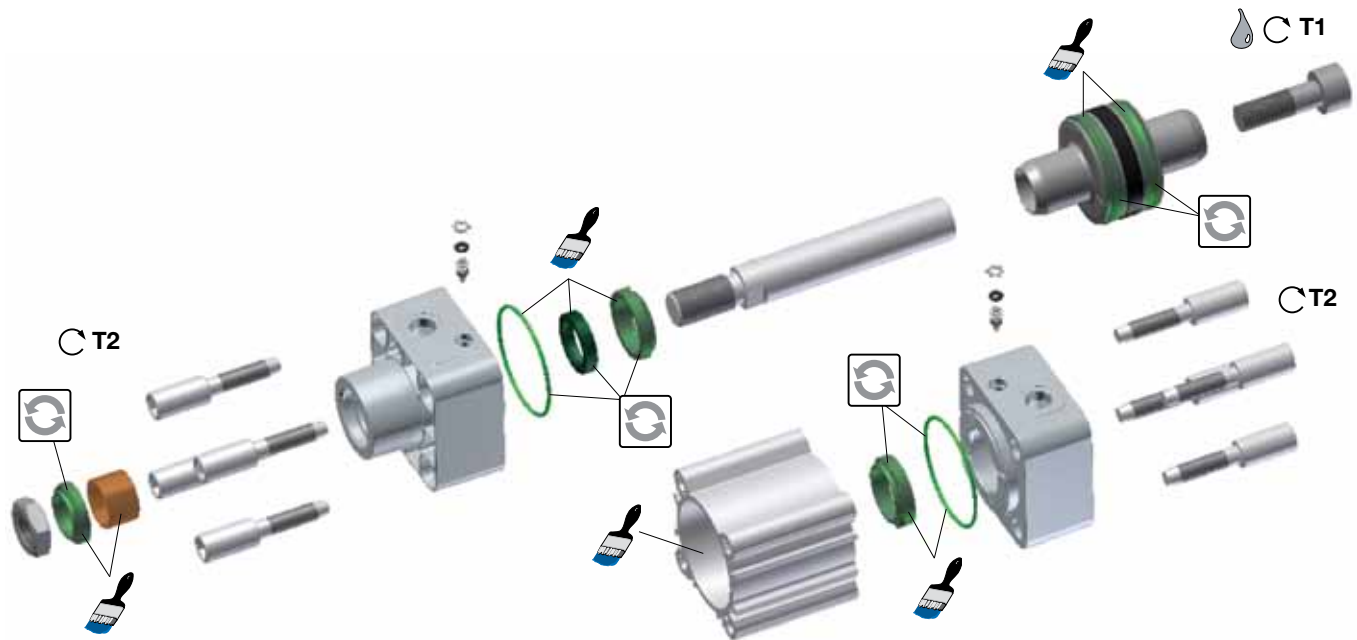

= Included in seal kit

= Lubricated with grease

= Socket head

= Locking fluid

= Tightening torque

Loctite 270 or Loctite 2701 locking fluid must be used

Cyl.-dia mm	Plastic piston T1 Nm	NV mm	T2 Nm	NV mm
32	4,5	6	8	6
40	11	8	8	6
50	20	10	20	8
63	20	10	20	8
80	40	14	20	6
100	120	14	20	6
125	120	14	70	8

Specifying air quality (purity) in accordance with ISO8573-1:2010, the international standard for Compressed Air Quality

ISO8573-1 is the primary document used from the ISO8573 series as it is this document which specifies the amount of contamination allowed in each cubic metre of compressed air.

ISO8573-1 lists the main contaminants as Solid Particulate, Water and Oil. The purity levels for each contaminant are shown separately in tabular form, however for ease of use, this document combines all three contaminants into one easy to use table.

ISO8573-1:2010 CLASS	Solid Particulate			Mass Concentration mg/m ³	Water		Oil
	Maximum number of particles per m ³				Vapour Pressure Dewpoint	Liquid g/m ³	Total Oil (aerosol liquid and vapour) mg/m ³
	0,1 - 0,5 micron	0,5 - 1 micron	1 - 5 micron				
0	As specified by the equipment user or supplier and more stringent than Class 1						
1	≤ 20 000	≤ 400	≤ 10	-	≤ -70 °C	-	0,01
2	≤ 400 000	≤ 6 000	≤ 100	-	≤ -40 °C	-	0,1
3	-	≤ 90 000	≤ 1 000	-	≤ -20 °C	-	1
4	-	-	≤ 10 000	-	≤ +3 °C	-	5
5	-	-	≤ 100 000	-	≤ +7 °C	-	-
6	-	-	-	≤ 5	≤ +10 °C	-	-
7	-	-	-	5 - 10	-	≤ 0,5	-
8	-	-	-	-	-	0,5 - 5	-
9	-	-	-	-	-	5 - 10	-
X	-	-	-	> 10	-	> 10	> 10

Specifying air purity in accordance with ISO8573-1:2010

When specifying the purity of air required, the standard must always be referenced, followed by the purity class selected for each contaminant (a different purity class can be selected for each contamination if required).

An example of how to write an air quality specification is shown below:

ISO 8573-1:2010 Class 1.2.1

ISO 8573-1:2010 refers to the standard document and its revision, the three digits refer to the purity classifications selected for solid particulate, water and total oil. Selecting an air purity class of 1.2.1 would specify the following air quality when operating at the standard's reference conditions :

Class 1 - Particulate

In each cubic metre of compressed air, the particulate count should not exceed 20,000 particles in the 0.1 - 0.5 micron size range, 400 particles in the 0.5 - 1 micron size range and 10 particles in the 1 - 5 micron size range.

Class 2 - Water

A pressure dewpoint (PDP) of -40°C or better is required and no liquid water is allowed.

Class 1 - Oil

In each cubic metre of compressed air, not more than 0.01mg of oil is allowed. This is a total level for liquid oil, oil aerosol and oil vapour.

ISO8573-1:2010 Class zero

- Class 0 does not mean zero contamination.
- Class 0 requires the user and the equipment manufacturer to agree contamination levels as part of a written specification.
- The agreed contamination levels for a Class 0 specification should be within the measurement capabilities of the test equipment and test methods shown in ISO8573 Pt 2 to Pt 9.
- The agreed Class 0 specification must be written on all documentation to be in accordance with the standard.
- Stating Class 0 without the agreed specification is meaningless and not in accordance with the standard.
- A number of compressor manufacturers claim that the delivered air from their oil-free compressors is in compliance with Class 0.
- If the compressor was tested in clean room conditions, the contamination detected at the outlet will be minimal. Should the same compressor now be installed in typical urban environment, the level of contamination will be dependent upon what is drawn into the compressor intake, rendering the Class 0 claim invalid.
- A compressor delivering air to Class 0 will still require purification equipment in both the compressor room and at the point of use for the Class 0 purity to be maintained at the application.
- Air for critical applications such as breathing, medical, food, etc typically only requires air quality to Class 2.2.1 or Class 2.1.1.
- Purification of air to meet a Class 0 specification is only cost effective if carried out at the point of use.

Parker Worldwide

Europe, Middle East, Africa

AE – United Arab Emirates, Dubai

Tel: +971 4 8127100
parker.me@parker.com

AT – Austria, Wiener Neustadt

Tel: +43 (0)2622 23501-0
parker.austria@parker.com

AT – Eastern Europe, Wiener Neustadt

Tel: +43 (0)2622 23501 900
parker.easteurope@parker.com

AZ – Azerbaijan, Baku

Tel: +994 50 2233 458
parker.azerbaijan@parker.com

BE/LU – Belgium, Nivelles

Tel: +32 (0)67 280 900
parker.belgium@parker.com

BY – Belarus, Minsk

Tel: +375 17 209 9399
parker.belarus@parker.com

CH – Switzerland, Etoy

Tel: +41 (0)21 821 87 00
parker.switzerland@parker.com

CZ – Czech Republic, Klecany

Tel: +420 284 083 111
parker.czechrepublic@parker.com

DE – Germany, Kaarst

Tel: +49 (0)2131 4016 0
parker.germany@parker.com

DK – Denmark, Ballerup

Tel: +45 43 56 04 00
parker.denmark@parker.com

ES – Spain, Madrid

Tel: +34 902 330 001
parker.spain@parker.com

FI – Finland, Vantaa

Tel: +358 (0)20 753 2500
parker.finland@parker.com

FR – France, Contamine s/Arve

Tel: +33 (0)4 50 25 80 25
parker.france@parker.com

GR – Greece, Athens

Tel: +30 210 933 6450
parker.greece@parker.com

HU – Hungary, Budapest

Tel: +36 1 220 4155
parker.hungary@parker.com

IE – Ireland, Dublin

Tel: +353 (0)1 466 6370
parker.ireland@parker.com

IT – Italy, Corsico (MI)

Tel: +39 02 45 19 21
parker.italy@parker.com

KZ – Kazakhstan, Almaty

Tel: +7 7272 505 800
parker.easteurope@parker.com

NL – The Netherlands, Oldenzaal

Tel: +31 (0)541 585 000
parker.nl@parker.com

NO – Norway, Asker

Tel: +47 66 75 34 00
parker.norway@parker.com

PL – Poland, Warsaw

Tel: +48 (0)22 573 24 00
parker.poland@parker.com

PT – Portugal, Leca da Palmeira

Tel: +351 22 999 7360
parker.portugal@parker.com

RO – Romania, Bucharest

Tel: +40 21 252 1382
parker.romania@parker.com

RU – Russia, Moscow

Tel: +7 495 645-2156
parker.russia@parker.com

SE – Sweden, Spånga

Tel: +46 (0)8 59 79 50 00
parker.sweden@parker.com

SK – Slovakia, Banská Bystrica

Tel: +421 484 162 252
parker.slovakia@parker.com

SL – Slovenia, Novo Mesto

Tel: +386 7 337 6650
parker.slovenia@parker.com

TR – Turkey, Istanbul

Tel: +90 216 4997081
parker.turkey@parker.com

UA – Ukraine, Kiev

Tel: +380 44 494 2731
parker.ukraine@parker.com

UK – United Kingdom, Warwick

Tel: +44 (0)1926 317 878
parker.uk@parker.com

ZA – South Africa, Kempton Park

Tel: +27 (0)11 961 0700
parker.southafrica@parker.com

North America

CA – Canada, Milton, Ontario

Tel: +1 905 693 3000

US – USA, Cleveland

Tel: +1 216 896 3000

Asia Pacific

AU – Australia, Castle Hill

Tel: +61 (0)2-9634 7777

CN – China, Shanghai

Tel: +86 21 2899 5000

HK – Hong Kong

Tel: +852 2428 8008

IN – India, Mumbai

Tel: +91 22 6513 7081-85

JP – Japan, Tokyo

Tel: +81 (0)3 6408 3901

KR – South Korea, Seoul

Tel: +82 2 559 0400

MY – Malaysia, Shah Alam

Tel: +60 3 7849 0800

NZ – New Zealand, Mt Wellington

Tel: +64 9 574 1744

SG – Singapore

Tel: +65 6887 6300

TH – Thailand, Bangkok

Tel: +662 186 7000-99

TW – Taiwan, Taipei

Tel: +886 2 2298 8987

South America

AR – Argentina, Buenos Aires

Tel: +54 3327 44 4129

BR – Brazil, Sao Jose dos Campos

Tel: +55 800 727 5374

CL – Chile, Santiago

Tel: +56 2 623 1216

MX – Mexico, Apodaca

Tel: +52 81 8156 6000

European Product Information Centre

Free phone: 00 800 27 27 5374

(from AT, BE, CH, CZ, DE, DK, EE, ES, FI, FR, IE, IL, IS, IT, LU, MT, NL, NO, PL, PT, RU, SE, SK, UK, ZA)

Parker Hannifin Ltd.

Tachbrook Park Drive
Tachbrook Park,
Warwick, CV34 6TU
United Kingdom
Tel.: +44 (0) 1926 317 878
Fax: +44 (0) 1926 317 855
parker.uk@parker.com
www.parker.com

